

# SUB-BINDER 1

---

Part 5 – Operators

OPERATOR INFORMATION

---

## Application of Caesars

JOINT BID CONSORTIUM

Primary Applicant

# Kambi

Applicants

CAESARS.  
SPORTSBOOK **POINTS**BET

 Resorts World

**RUSH STREET**  
INTERACTIVE **wynn**BET

# **New York State Gaming Commission**

**Request for Applications for Mobile Sports Wagering  
Platform Providers**

## **PART 5 – OPERATOR INFORMATION**

**CAESARS  
SPORTSBOOK**

**August 2021**

## **TABLE OF CONTENT**

<b>5.1 OPERATOR.....</b>	<b>2</b>
<b>5.2 NUMBER OF OPERATORS TO BE HOSTED .....</b>	<b>2</b>
<b>5.3 OPERATOR ORGANIZATION .....</b>	<b>2</b>
<b>5.4 APPLICANT AS AN OPERATOR .....</b>	<b>13</b>
<b>5.5 LICENSURE .....</b>	<b>13</b>
<b>5.6 ADVERTISING AND PROMOTIONAL PLANS .....</b>	<b>14</b>

The Applicant shall include a separate subdivision within Sub-Binder 1 for each Operator to be hosted, comprised of material required to be submitted in response to each section contained within this Part.

## 5.1 OPERATOR

**The responsibilities, duties and requirements of an Operator are defined and determined, by context, in the draft regulation Part 5330, which has been included as Appendix A: Draft Regulation Part 5330.**

Caesars understands the requirements of and agrees to operate according to the requirements of draft regulation Part 5330.

## 5.2 NUMBER OF OPERATORS TO BE HOSTED

**The Applicant shall identify the number of Operators the Applicant proposes to host on the Applicant's Platform.**

Caesars owns and controls its proprietary sports betting platform, Liberty, which is currently deployed in eight states. Built specifically for the U.S. market, Liberty is a modern, scalable platform which fuels innovative and differentiated products.

Caesars is the only operator on the Liberty platform, as it was designed and built for Caesars' own business-to-consumer use.

## 5.3 OPERATOR ORGANIZATION

**For each Operator the Applicant proposes to host as part of this Application, the Applicant shall provide the full name of the Operator as it appears on such Operator's certificate of incorporation, charter or other official formation document, along with any D/B/A or trade names.**

**The Application shall include for each proposed Operator, information on the Operator consistent with that required for the Applicant pursuant to Sections 4.3 through 4.14 of Part 4 of this RFA.**

**4.2 NAME OF APPLICANT: The Applicant's full name as it appears on the Applicant's certificate of incorporation, charter, or other official formation document (as amended), as well as any D/B/A or trade names.**

American Wagering, Inc. d/b/a Caesars Sportsbook ("Caesars")

**4.3 CONTACT PERSON: The name, title, email address and telephone number of the individual to be contacted for the Applicant in reference to the Application.**

Name: Jeffrey Hendricks

Title: Senior Vice President, Regulatory & Compliance, Caesars Entertainment

E-mail: [REDACTED]

Phone: [REDACTED]

**4.4 LOCATION OF THE APPLICANT'S PRINCIPAL PLACE OF BUSINESS: The street address, city, state, zip code and telephone number for the Applicant's principal place of business, as well as the URL for any website maintained by or for the Applicant.**

Primary Location:

- Address: 6325 S. Rainbow Blvd, Suite 100, Las Vegas, NV 89118
  - Phone: (702) 754-1800

Secondary Locations:

- Address: 1 Caesars Palace Drive, Las Vegas, NV 89109
- Address: 100 West Liberty Street, 12<sup>th</sup> Floor, Reno, NV 89501

URLs:

- <https://www.caesars.com/sportsbook>
- <https://www.caesars.com/>
- <https://investor.caesars.com/>
- <https://www.williamhill.com/us>
- <https://www.williamhillplc.com/>

**4.5 TYPE OF BUSINESS FORMATION: The type of business entity under which the Applicant is formed (e.g., corporation, limited liability company, partnership), the state (or other jurisdiction) of formation and the Federal Tax Identification Number (also known as the Federal Employer Identification Number). Attach evidence of the entity's current ability to conduct business (e.g., certificate of good standing, certificate of status) from the state (or other jurisdiction) of formation as of a date not earlier than 10 days prior to the submission of the Application.**

American Wagering, Inc. is a Nevada corporation. Its FEIN number is 88-0344658. Included with the RFA are certificates of good standing for Nevada and New York.

**See Exhibit A – AWI – NV Certificate of Existence**

**See Exhibit B – AWI – NY-Good Standing**

**4.6 TABLE OF OWNERSHIP: A full and complete ownership chart for the Applicant and its affiliates including percentage ownership interests in the Applicant by its respective direct and indirect owners, illustrating the ultimate beneficial owners. For a publicly held company, disclosure of owners may be limited to owners owning five percent or more of the publicly held company.**

Included with the RFA is a complete ownership chart for Caesars Entertainment, Inc., the ultimate parent company of American Wagering, Inc. Please refer to page 24 of the chart for ownership information specific to American Wagering, Inc.

**See Exhibit C – Caesars Entertainment Org Chart [CONFIDENTIAL]**

Caesars Entertainment, Inc. is publicly traded on the NASDAQ and has no natural person owning more than five percent (5%). Included with the RFA is a chart reflecting institutional investors holding five percent (5%) or more.

**See Exhibit D – 5% or more owners in Caesars Entertainment (06.30.2021) [CONFIDENTIAL]**

**4.7 ORGANIZATIONAL CHART: An organizational chart of the Applicant including all key employees anticipated to be licensed as such pursuant to Appendix A: Draft Regulation Part 5330 of the Commission's regulations, when adopted.**

Included with the RFA is an organizational chart of the Caesars Digital Leadership and Operations team.

***See Exhibit E – Caesars Digital Leadership and Operations Org Chart***

**4.8 NAMES, ADDRESSES AND EXPERIENCE OF DIRECTORS AND OFFICERS:** The name, address, and title of each Director or General Partner of the Applicant and each officer and proposed key employee of the Applicant, within the meaning of Appendix A: Draft Regulation Part 5330 and resumes or C.V.s of all principals and known individuals who will perform executive management duties or oversight of the Applicant.

The address for all principals associated with this application is 100 West Liberty Street, 12th Floor, Reno, Nevada 89501. The title and resume for each of the principals associated with this application are included for reference below:

**Executive Officers & Directors:**

**Gary Carano, Director and Executive Chairman (Caesars Entertainment)**

Mr. Carano was named Executive Chairman of the Board in January of 2019. Previously, he served as Chief Executive Officer and Chairman of the Board of Eldorado Resorts, Inc. since September 2014. He has more than 30 years of experience in the gaming and hotel industry. Previously, Mr. Carano served as President and Chief Operating Officer of Eldorado Resorts, LLC, where he directed and oversaw all aspects of the Company's development and operations in Nevada and Louisiana. Mr. Carano also served as General Manager and Chief Executive Officer of the Silver Legacy Resort Casino, a joint venture between the Eldorado and MGM Resorts International, from its opening in 1995 until 2014.

In addition to working for Eldorado Resorts, Mr. Carano is an active philanthropist, serving on a number of charitable boards and foundations in the State of Nevada. Mr. Carano holds a B.A. from the University of Nevada.

**Thomas Reeg, Director and Chief Executive Officer (Caesars Entertainment, William Hill U.S. HoldCo, Inc., American Wagering, Inc.)**

Mr. Reeg was appointed Chief Executive Officer of Eldorado Resorts, Inc. in 2019 and has been a member of the Board of Directors since September 2014. Previously, he served as President for Eldorado Resorts, Inc. from 2014 to 2019. From January 2011 through September 2014, Mr. Reeg served as Senior Vice President of Strategic Development at Eldorado Resorts, LLC. From December 2007 through September 2014, he was also a member of Eldorado Resorts, LLC's Board of Managers.

Mr. Reeg was a founding partner and Senior Managing Director of Newport Global Advisors L.P. ("Newport") from September 2005 through November 2010. Prior to joining Newport, Mr. Reeg held a number of positions in the financial service industry, most recently, Managing Director of AIG Global Investment Group from 2002 to September 2005. Mr. Reeg holds a B.B.A. from the University of Notre Dame.

**Anthony Carano, President and Chief Operating Officer (Caesars Entertainment, William Hill U.S. HoldCo, Inc., American Wagering, Inc.)**

Mr. Carano is President and Chief Operating Officer of Eldorado Resorts, Inc. since January 2019. Mr. Carano served as Executive Vice President, General Counsel, and Secretary to Eldorado Resorts, Inc., from September 2014 to December 2018. Prior to joining the Eldorado, he was an attorney at the Nevada law firm of McDonald Carano Wilson, LLP, where his practice was devoted primarily to transactional, gaming, and regulatory law.

New York State Gaming Commission  
Request for Applications for Mobile Sports Wagering Platform Providers  
Caesars Sportsbook

Mr. Carano received a B.A. from the University of Nevada, a J.D. from the University of San Francisco, School of Law, and an M.B.A. in Finance from the University of San Francisco, School of Business.

**Josh Jones, Chief Marketing Officer (Caesars Entertainment)**

Josh Jones is Chief Marketing Officer of Caesars Entertainment. Prior to the acquisition, he served as Senior Vice President of Operations of Eldorado Resorts, Inc. As SVP of Operations, he helped lead the acquisition and integration of Caesars and several other gaming companies.

Mr. Jones initially joined the Eldorado team nearly 20 years ago, working Valet at the Eldorado in Reno and also worked for a short time in the Eldorado Poker Room. His career took him into the finance and wine worlds, coming full circle back to Eldorado in 2014 as a Senior Financial Analyst.

Mr. Jones holds a Master of Business Administration and a Bachelor of Science in International Business from the University of Nevada, Reno.

**Stephanie Lepori, Chief Administrative & Accounting Officer (Caesars Entertainment)**

Stephanie Lepori is Chief Administrative and Accounting Officer of Caesars Entertainment. Ms. Lepori's proven leadership and financial management skills played a significant role in the execution of growth initiatives of Eldorado Resorts, Inc. and the acquisition of Caesars Entertainment Corporation.

Ms. Lepori has more than two decades of experience in finance and gaming, and has been with the Company since 1995, beginning with the opening of Silver Legacy Casino Resort in Reno. Prior to joining the Company, Ms. Lepori started her career with Arthur Anderson LLP in Las Vegas.

Ms. Lepori has a passion for community work and has served on a number of charitable boards. She currently serves on the Boys and Girls Club of Truckee Meadows Board of Directors and Renown Health's Compliance and Audit Committee and their Hometown Health Insurance Board of Directors. Ms. Lepori earned a Bachelor of Science Degree in Accounting and Magna Cum Laude and Phi Beta Kappa honors from the University of Southern California. She is a Certified Public Accountant and a member of the Nevada Society of CPAs.

**Bret Yunker, Chief Financial Officer (Caesars Entertainment, William Hill U.S. HoldCo, Inc., American Wagering, Inc.)**

Bret Yunker is Chief Financial Officer of Caesars Entertainment. He served as Chief Financial Officer of Eldorado Resorts, Inc. since May 2019, before the acquisition of Caesars Entertainment Corporation. Mr. Yunker is responsible for all of the Company's financial and treasury functions, including financial reporting, bank relationships, conducting internal and industry analysis to support the Company's goals for growth, investor relations, and M&A activity. In addition, department leadership of strategic business services and IT, tax, procurement, data analytics, and design and construction will report to Mr. Yunker.

Mr. Yunker brings more than 20 years of gaming industry investment banking experience to his position, most recently he served as Managing Director at J.P. Morgan in its Real Estate Investment Banking group with primary coverage responsibility for the domestic and international gaming industry. In this role, he worked with clients across several sectors within the gaming industry, including casino operators, gaming equipment and system suppliers, REITs, lottery service providers, and online gaming companies.

Mr. Yunker began his banking career in 1998, serving for 14 years in various investment banking roles, including as Managing Director at Bank of America Merrill Lynch. His work with clients over the last 20 years includes broad geographic coverage, including North America, Europe, Asia, and other emerging markets.

Mr. Yunker's proven financial expertise and extensive industry relationships are an invaluable asset to Caesars as we seek to continue to build value for our shareholders.

**Edmund L. Quatmann, Chief Legal Officer (Caesars Entertainment, William Hill U.S. HoldCo, Inc., American Wagering, Inc.)**

Edmund L. Quatmann, Jr., is Chief Legal Officer of Caesars Entertainment. He served as Chief Legal Officer for Eldorado Resorts since May 2017, before the acquisition of Caesars Entertainment Corporation. Mr. Quatmann previously served as Chief Legal Officer and Secretary of Isle of Capri Casinos, Inc. since July 2011 and July 2008, respectively, and as Senior Vice President, General Counsel, and Secretary for iPCS, Inc., a telecommunications company.

He also worked in corporate and securities practice in the Chicago office of Mayer Brown LLP. Mr. Quatmann is a graduate of Purdue University and received his J.D. from Saint Louis University School of Law.

**Eric Hession, Co-President, Caesars Sports & Online Gaming**

Eric Hession currently serves as Co-President of Caesars Sports and Online Gaming for Caesars Entertainment. Over the course of his tenure at Caesars, he has held positions in both property operations and corporate finance. While in operations, Eric led the planning and analysis, revenue management, distribution, and accounting efforts for Caesars' 12 Nevada properties. He most recently served as Chief Financial Officer, where his responsibilities included the leadership of treasury, investor relations, risk management, procurement, and M&A. Prior to his employment with Caesars, Eric spent five years with Merck and Company, working in various capacities in Pennsylvania, North Carolina, and their New Jersey corporate headquarters.

Eric grew up in Pittsford, Vermont, and attended Cornell University, where he received a Bachelor of Science in Operations Research and Industrial Engineering. He also holds an MBA from The Fuqua School of Business at Duke University.

**Christopher Holdren, Co-President, Caesars Sports & Online Gaming**

Christopher Holdren currently serves as Co-President of Caesars Sports and Online Gaming. He joined Caesars in 2017 as Chief Marketing Officer after serving in a similar role for Handy, a high-growth technology start-up. Mr. Holdren has extensive marketing and creative experience from both corporate and start-up environments, including more than 15 years in senior roles at Starwood Hotels & Resorts Worldwide, where he led loyalty, digital, partnerships, and other global marketing functions. Holdren also held creative roles at The Walt Disney Company and Saban Entertainment.

Mr. Holdren grew up in Charlottesville, Virginia, and attended Virginia Tech, where he received a Bachelor of Arts.

**Non-Executive Directors:**

**Jan Jones Blackhurst, Director**

Ms. Jones Blackhurst served as a director of Former Caesars from October 2019 until the Merger in July 2020, at which time she joined the Board. Ms. Jones Blackhurst served as Executive Vice President, Public Policy and Corporate Responsibility of Former Caesars from May 2017 through September 2019. Ms. Jones Blackhurst also served as Executive Vice President of Communications and Government Relations of Former Caesars from November 2011 until May 2017 and as Senior Vice President of Communications and Government Relations of Former Caesars from November 1999 to November 2011. Ms. Jones Blackhurst has over 20 years of experience in the gaming industry and has played a key role in innovating responsible gaming programs that are now used throughout the industry.



New York State Gaming Commission  
Request for Applications for Mobile Sports Wagering Platform Providers  
Caesars Sportsbook

Ms. Jones Blackhurst serves as the Chairwoman of the Public Education Foundation, and Chief Executive-In-Residence of the UNLV International Gaming Institute. Since February 2021, Ms. Jones Blackhurst has served as a director of Gaming & Hospitality Acquisition Corp. Prior to joining Former Caesars, Ms. Jones Blackhurst served two terms as Mayor of Las Vegas from 1991 until 1999.

Ms. Jones Blackhurst brings to the Board significant experience in corporate social responsibility matters, including policies on responsible gaming, specifically within the gaming industry, and government relations experience.

**Frank J. Fahrenkopf, Director**

Mr. Fahrenkopf has served on the Board since 2014. He served as President and Chief Executive Officer of the American Gaming Association (“AGA”), an organization that represents the commercial casino-entertainment industry by addressing federal legislation and regulatory issues, from 1995 until 2013. At the AGA, Mr. Fahrenkopf was the national advocate for the commercial casino industry and was responsible for positioning the AGA to address regulatory, political, and educational issues affecting the gaming industry. Mr. Fahrenkopf is currently Co-Chairman of the Commission on Presidential Debates, which he founded, and which conducts debates among presidential candidates. He serves as a board member of the International Republican Institute, which he founded. He also founded the National Endowment for Democracy, where he served as Vice Chairman and a board member from 1983 to 1992. Mr. Fahrenkopf served as Chairman of the Republican National Committee from 1983 to 1989.

Prior to his role at AGA, Mr. Fahrenkopf was a partner at Hogan & Hartson, where he regularly represented clients before the Nevada gaming regulatory authorities. Mr. Fahrenkopf served as the first chairman of the American Bar Association Committee on Gaming Law and was a founding Trustee and President of the International Association of Gaming Attorneys. Mr. Fahrenkopf also sits on the board of directors of 12 NYSE-listed public companies: First Republic Bank, Gabelli Equity Trust, Inc., Gabelli Utility Trust, Gabelli Global Multimedia Trust, Gabelli Dividend and Income Trust, Gabelli Gold and Natural Resources, Gabelli Small & Midcap Value Fund, Gabelli Goanywhere Trust, Gabelli Natural Resources, Gold & Income Trust, Gabelli NextShares Trust, Bankcroft Fund, and Ellsworth Growth & Income Trust.

Mr. Fahrenkopf has been selected to serve as a director because of his extensive knowledge of gaming regulatory matters, his relevant legal experience, and his experience as a director of several public companies.

**Don Kornstein, Director**

Mr. Kornstein served as a director of Former Caesars from October 2017 until the Merger in July 2020, at which time he joined the Board and was appointed as Vice Chairman. Since November 2020, Mr. Kornstein has also served as Chairman of the Board of Directors of Caesars Entertainment UK Limited. Mr. Kornstein founded and has served as the managing member of the strategic management and financial consulting firm Alpine Advisors LLC, an advisory firm engaged in the business of mergers and acquisitions and capital raising for entrepreneurs and companies. During his tenure, Mr. Kornstein also served as Chairman of the Transaction Committee and the Strategy & Finance Committee. Mr. Kornstein served on the Board of Directors of Caesars Acquisition Company from January 2014 until the merger with the Caesars Entertainment Corporation. He previously served as a non-executive Director on the Board of Gala Coral Group, Ltd., a diversified gaming company based in the United Kingdom, from June 2010 until its merger with Ladbrokes PLC in November 2016. He has served as Chairman of the Board of Directors of Affinity Gaming, Inc., a casino gaming company, from March 2010 until January 2014, and Chief Restructuring Officer and Chairman of the Board of Directors of Bally Total Fitness Corporation. Mr. Kornstein has also served as a member of the Boards of Directors of Circuit City Stores, Inc., Cash Systems, Inc., Shuffle Master, Inc., and Varsity Brands, Inc. Mr. Kornstein served as Chief Executive Officer, President, and Director of Jackpot Enterprises, Inc., which was a NYSE-listed gaming company until its sale, and was an investment banker and Senior Managing Director of Bear, Stearns & Co. Inc.

Mr. Kornstein brings to the Board his extensive experience in the gaming and entertainment industry, experience as a chairman and officer, financial expertise, practical experience relating to evaluation and execution of strategic alternatives, and experience serving on several boards of directors.

**Courtney Mather, Director**

Mr. Mather served as a director of Former Caesars from March 2019 until the Merger in July 2020, at which time he joined the Board. Mr. Mather served as Portfolio Manager of Icahn Capital LP, the entity through which Carl C. Icahn manages investment funds, from December 2016 to March 2020, and was previously Managing Director of Icahn Capital LP from April 2014 to November 2016. Prior to joining Icahn Capital LP, Mr. Mather was at Goldman Sachs & Co. from 1998 to 2012, most recently as Managing Director responsible for Private Distressed Trading and Investing, where he focused on identifying and analyzing investment opportunities for both Goldman Sachs and clients. Mr. Mather has served as a director of Newell Brands Inc., a manufacturer and marketer of a broad range of consumer products, since March 2018. Mr. Mather was previously a director of: Cheniere Energy Inc. from May 2018 to February 2021; Conduent Inc. from December 2016 to February 2021; Herc Holdings Inc. from June 2016 to August 2019; Ferrous Resources Limited from June 2015 to July 2019; Freeport-McMoRan Inc. from October 2015 to March 2019; Federal-Mogul Holdings Corporation from May 2015 to January 2017; Viskase Companies Inc. from June 2015 to March 2016; American Railcar Industries Inc. from July 2014 to March 2016; CVR Refining LP from May 2014 to March 2016; and CVR Energy Inc. from May 2014 to March 2016. Mr. Mather holds the Chartered Alternative Investment Analyst, Chartered Financial Analyst, and Certified Financial Risk Manager professional designations.

Mr. Mather brings to the Board his significant business and financial expertise and experience providing strategic advice and guidance to companies on matters such as risk management through his service as a director on various public company boards of directors.

**Michael Pegram, Director**

Mr. Pegram has served on the Board since September 2014. Mr. Pegram has been a partner in the Carson Valley Inn in Minden, Nevada since June 2009, and a partner in the Bodines Casino in Carson City, Nevada since January 2007. Mr. Pegram is the managing member of Gpeg, which owns and operates five casinos in the Reno and Carson City area. Mr. Pegram has more than 45 years of experience owning and operating 25 successful McDonald's franchises. Mr. Pegram currently serves as a director of, and is the former Chairman of, the Thoroughbred Owners of California and has been the owner of a number of racehorses, including 1998 Kentucky Derby and Preakness Stakes winner, Real Quiet, 2010 Preakness Stakes winner, Lookin at Lucky, 1998 Breeders' Cup Juvenile Fillies winner and 1999 Kentucky Oaks winner, Silverbulletday, 2001 Dubai World Cup winner, Captain Steve, and the 2007 and 2008 Breeders' Cup Sprint winner, Midnight Lute. Additionally, Mr. Pegram has served as a director of Skagit State Bancorp from April 1997 to November 2018.

Mr. Pegram has been selected to serve as a director because of his extensive experience in the horse racing industry and as an investor, business owner, and director of various casino operations.

**David P. Tomick, Director**

Mr. Tomick has served on the Board since September 2014. Mr. Tomick co-founded Securus, Inc., a company involved in the GPS monitoring and Personal Emergency Response business, and served as its Chief Financial Officer from 2008 until 2010 and as its Chairman from 2010 to 2015. From 1997 to 2004, Mr. Tomick was Executive Vice President and Chief Financial Officer of SpectraSite, Inc., an NYSE-listed wireless tower company. Mr. Tomick was, from 1994 to 1997, the Chief Financial Officer of Masada Security, a company involved in the security monitoring business and, from 1988 to 1994, the Vice President-Finance of Falcon Cable TV, where he was responsible for debt management, mergers and acquisitions, equity origination, and investor relations. Prior to 1988, he managed a team of corporate finance professionals focusing on the communications industry for The First National Bank of Chicago. Mr. Tomick currently serves on the board of directors of Gryppers, Inc., Autocam Medical, and First Choice

New York State Gaming Commission  
Request for Applications for Mobile Sports Wagering Platform Providers  
Caesars Sportsbook

Packaging, and has served on the board of the following organizations: Autocam Corporation, NuLink Digital, and TransLoc, Inc.

Mr. Tomick has been selected to serve as a director because of his financial and management expertise and his experience with respect to raising capital, mergers and acquisitions, corporate governance, and investor relations.

**4.9 LOBBYIST REGISTRATION REQUIREMENT: PML Section 1329 requires each lobbyist seeking to engage in lobbying activity on behalf of a client or a client's interest before the Commission to first register with the secretary of the Commission. While this obligation falls to the lobbyist, Applicant identification of its lobbyists is requested.**

**CONFIDENTIAL INFORMATION BEGINS HERE**

**New York Registered Lobbyists – Firms Under Contract**

- Bolton St. Johns
  - Giorgio DeRosa, Partner
  - Justin Berhaupt, Senior Vice President
  
- Park Strategies, LLC
  - Senator Alfonse M. D'Amato, Founder, Partner, & Managing Director
  - Christopher D'Amato, Executive Vice President, Partner, & General Counsel
  - David Poleto, Partner & Managing Director
  - Jeff Lovell, Managing Director
  - Ryan Moses, Managing Director
  - Joe Rossi, Managing Director

**New York Registered Lobbyists – Caesars Employees**

- Thomas Reeg, Chief Executive Officer, Caesars Entertainment
- Joseph Tyrrell, Vice President of Government Relations Reg, Caesars Entertainment

**CONFIDENTIAL INFORMATION ENDS HERE**

**4.10 NAMES, ADDRESSES AND OWNERSHIP AND OTHER INTERESTS: The name and business address of each person or entity who or that has a direct or indirect ownership or other proprietary interest (financial, voting or otherwise) in five percent or more in the Applicant.**

American Wagering, Inc. is 100% held by William Hill U.S. HoldCo, Inc., which is 100% held by Caesars Entertainment, Inc., a publicly traded company on the NASDAQ.

Entity Name: William Hill U.S. HoldCo, Inc.

Business Address: 6325 South Rainbow Boulevard, Suite 100, Las Vegas, NV 89118

Entity Name: Caesars Entertainment, Inc.

Business Address (Corporate Headquarters): 100 West Liberty Street, 12<sup>th</sup> Floor, Reno, NV 89501

**4.11 CONFLICTS OF INTEREST: A description of any relationship or affiliation of the Applicant or any of the Applicant's affiliates that currently exists or existed in the past five years with any member, employee, consultant or agent of the Commission that is a conflict of interest or may be**

perceived as a conflict of interest during the RFA process. Further, if any such conflict should arise during the term of the RFA process, the Applicant shall notify immediately the Commission, in writing, of such conflict.

The Commission shall make the final determination as to whether any activity constitutes a conflict of interest pursuant to this provision. The Commission's decision shall be final; however, the Commission will not make any such decision without providing the Applicant with an opportunity to present comments.

If an Applicant does not identify any direct or indirect conflict of interest, or perceived conflict of interest, at the time the Applicant submits the Applicant's Application, the Applicant shall state that no conflict or perceived conflict of interest exists with respect to such Application. If the Applicant identifies a conflict of interest or perceived conflict of interest, the Applicant shall disclose the conflict and the steps the Applicant will take to resolve such conflict.

Caesars is unaware of any relationship or affiliation between Caesars or any of Caesars' affiliates that currently exists or existed in the past five years with any member, employee, consultant or agent of the Commission that is a conflict of interest or may be perceived as a conflict of interest during the RFA process. However, Caesars is a publicly traded company that is a member of the S&P 500. Accordingly, Caesars' shares may be held by individuals associated with the Commission who either own the shares directly, through funds that invest in the S&P 500 index or other investment vehicles. Given the difficulty of determining the ownership of a specific share in a publicly traded time at any given time, Caesars is unaware of any specific ownership of Caesars' shares by members, employees, consultants or agents of the Commission. Should a member, employee, consultant or agent of the Commission own publicly traded shares in Caesars, Caesars would not consider such passive investment activities to constitute a conflict of interest or perceived conflict of interest. Accordingly, Caesars states that no conflict or perceived conflict of interest exists with respect to this Application.

Additionally, various portions of Caesars' financings are held by accredited institutional investors in funds that are either traded directly on various stock exchanges or are held by investment funds that may have public investors. Accordingly, members, employees, consultants or agents of the Commission, may have indirect or direct interest in various debt instruments associated with Caesars. Caesars is unaware of any material interest in Caesars' various financings by any members, employees, consultants or agents of the Commission.

Accordingly, Caesars states that no conflict or perceived conflict of interest exists with respect to this Application.

If any such conflict or perceived conflict of interest is identified during the term of the RFA process, Caesars will immediately notify the Commission, in writing, of such conflict or perceived conflict of interest.

**4.12 PUBLIC OFFICIALS:** Submit a list of names, titles, addresses and telephone numbers of any public officials or officers or employees of any governmental entity, and immediate family members of any such public officials, officers or employees, to the extent known, who, directly or indirectly, own any financial interest in, have any beneficial interest in, are the creditors of, hold any debt instrument issued by, or hold or have an interest, direct or indirect, in any contractual or service relationship with the Applicant or their Affiliates. Also submit a statement listing all persons and entities not listed in the immediately preceding sentence who or that have any arrangement, written or oral, to receive any compensation from anyone in connection with the Application, the RFA process or the process of obtaining of a License from the State, describing the nature of the arrangement, the service to be provided and the amount of such compensation, whether actual or contingent.



[REDACTED]

[REDACTED]

[REDACTED]

- [REDACTED]
- [REDACTED]

[REDACTED]

[REDACTED]

**4.13 CONTRACTS WITH THE STATE OF NEW YORK:** Submit a list of any current or previous contracts that the Applicant or its affiliates has had with, and any current or previous licenses that the Applicant has been issued by or under, any department or agency of the State. Include the contract or license name and number and a concise explanation of the nature of the contract or license.

Caesars is unaware of any contract that Caesars or its affiliates currently have or had within the past five years with any department or agency of the State. If any such contract is identified during the term of the RFA process, Caesars will immediately notify the Commission, in writing, of such contract and will include the contract name and number and a concise explanation of the nature of the contract.

Separately, American Wagering, Inc. was awarded a temporary gaming service registration by the New York State Gaming Commission in December 2020 to conduct gaming-related business with the Oneida Indian Nation of New York's class III gaming facilities. Additionally, Caesars Enterprise Services, a subsidiary of Caesars Entertainment, was issued a temporary gaming service registration in July 2019 to conduct business with Oneida Indian Nation gaming facilities.

**4.14 ORGANIZATIONAL DOCUMENTS: Submit, as applicable, copies of the following documents that apply to the Applicant or the Applicant's owners:**

**A. certified copy of each relevant certificate of incorporation, articles of incorporation or corporate charter**

Certified copy of the Second Amended and Restated Articles of Incorporation for American Wagering, Inc.

***See Exhibit F – American Wagering – Certified Copies of NV Articles of Inc. Registration***

Certified copy of the Certificate of Incorporation for William Hill U.S. HoldCo, Inc.

***See Exhibit G – William Hill US Holdco – Certified copies of Articles of Incorporation***

Certified copy of the Certificate of Incorporation for Caesars Entertainment, Inc.

***See Exhibit H – Caesars Entertainment Certificate of Incorporation***

***See Exhibit I – Caesars Entertainment Amendment to the Certificate of Incorporation***

**B. by-laws as amended through the date of the Application**

Copy of the Fifth Amended and Restate Bylaws of American Wagering, Inc.

***See Exhibit J – American Wagering, Inc. – Bylaws 5th A&R***

Copy of the Second Amended and Restated Bylaws of William Hill U.S. Holdco, Inc.

***See Exhibit K – William Hill US Holdco-2nd Amended Bylaws***

Certified copy of the Bylaws for Caesars Entertainment, Inc.

***See Exhibit L – Caesars Entertainment, Inc. Bylaws***

**C. certified copy of its certificate of formation or articles of organization of a limited liability company**

Not applicable

**D. limited liability company agreement or operating agreement as amended through the date of the Application**

Not applicable

**E. certified copy of each relevant certificate of partnership**

Not applicable

**F. partnership agreement as amended through the date of the Application**

Not applicable

**G. certified copy of each relevant certificate of limited partnership**

Not applicable

**H. limited partnership agreement as amended through the date of the Application**

Not applicable

**I. other legal instruments of organization**

Not applicable

**J. joint venture agreement**

Not applicable

**K. trust agreement or instrument, each as amended through the date of the Application**

Not applicable

**L. voting trust or similar agreement**

Not applicable

**M. stockholder, member or similar agreement**

Not applicable

## **5.4 APPLICANT AS AN OPERATOR**

The type of business entity under which the Applicant is formed (e.g., corporation, limited liability company, partnership), the state (or other jurisdiction) of formation and the Federal Tax Identification Number (also known as the Federal Employer Identification Number). Attach evidence of the entity's current ability to conduct business (e.g., certificate of good standing, certificate of status) from the state (or other jurisdiction) of formation as of a date not earlier than 10 days prior to the submission of the Application.

American Wagering, Inc. is a Nevada corporation. Its FEIN number is 88-0344658. Included with the RFA are certificates of good standing for Nevada and New York.

**See Exhibit A – AWI – NV Certificate of Existence**

**See Exhibit B – AWI – NY-Good Standing**

## **5.5 LICENSURE**

Each Operator must be licensed as a Mobile Sports Wagering Licensee, separate from the Mobile Sports Wagering License issued to the Platform Provider. The standard for licensing shall be equivalent to that of a Casino Vendor Enterprise pursuant to PML Article 13 Title 4 – Enterprise and Vendor Licensing and Registration.

Caesars is pursuing licensing as a Mobile Sports Wagering Licensee.

American Wagering, Inc. was awarded a temporary gaming service registration by the New York State Gaming Commission in December 2020 to conduct gaming-related business with the Oneida Indian Nation of New York's class III gaming facilities. Additionally, Caesars Enterprise Services, a subsidiary of Caesars Entertainment, was issued a temporary gaming service registration in July 2019 to conduct business with Oneida Indian Nation gaming facilities.

## 5.6 ADVERTISING AND PROMOTIONAL PLANS

The Applicant shall provide detailed information demonstrating the marketing and promotion efforts proposed by its Operators, including:

### Estimated marketing budget

Now that the former William Hill app has been totally rebranded and relaunched as Caesars Sportsbook, Caesars is investing significantly in advertising and marketing.

Few things beat the emotional high of placing a bet. Sports betting consumers love the self-satisfaction of being right and the emotional and intellectual excitement that comes from watching a game where they've placed a bet. However, even with all that passion, most bettors feel unrecognized and under-appreciated. Not at Caesars.

When we enter New York, we will treat New Yorkers like royalty from the beginning. Founder Jay Sarno created Caesars Palace in Las Vegas with the belief that everyone should have the opportunity to be treated like royalty. He removed the apostrophe in our name to signify that Caesars would be for everyone, not just Caesar. This summer, we will launch a character, Caesar, who will make sure New Yorkers feel they matter in sports betting by recognizing their passion and elevating their importance. We will be providing an experience that's worthy of all New Yorkers and one that's more effortless, fun and rewarding to get in on the action with Caesars Rewards, the largest casino rewards program in the country, with more than 60 million members.

**CONFIDENTIAL INFORMATION BEGINS HERE**



**CONFIDENTIAL INFORMATION ENDS HERE**



New York State Gaming Commission  
Request for Applications for Mobile Sports Wagering Platform Providers  
Caesars Sportsbook

For a short video showing how we will bring Caesars Sportsbook to life in New York, [click here](#) or click on image below.



**CONFIDENTIAL INFORMATION BEGINS HERE**

[Redacted]

[Redacted]	[Redacted]
[Redacted]	[Redacted]
[Redacted]	[Redacted]

**CONFIDENTIAL INFORMATION ENDS HERE**

## Advertising plans

Our advertising showcases Caesar (played by comedian-actor JB Smoove) treating customers like royalty in a humorous, episodic way. Only Caesars can give bettors Caesars Rewards, an easy-to-use product, and service that they deserve.



## Launch

For New York state's launch, Caesars will focus its marketing efforts around three pillars:

1. **Seize the Day:** we are share-worthy and disruptive through marquee sponsorship activations, locally relevant events, PR, and a Caesars-sized media campaign
2. **We put our odds everywhere:** in content (ESPN, CBS Sports), in advertising, and through our spokespeople to drive familiarity, education, responsible gaming messaging and enthusiasm of sports betting
3. **We are an empire apart in the Empire State:** we make sure that sports bettors know that Caesars Rewards is a key differentiator

## Media Mix

We use media to reinforce the quality of the Caesars experience and brand, our commitment to responsible gaming, as well as to provide unique offers to sports fans and bettors. Our approach to forecasting and spending media is highly data-driven and optimized on a weekly, monthly, and annual basis. We will leverage years of experience to successfully launch in New York, acquire new sports betting customers, shift current sports bettors from unlicensed competitors, and sustain engagement.

### *Channel overview:*

- TV/Radio/Billboards to create awareness and education.
- Direct response media using e-mail, direct mail, affiliate programs, the Caesars database, social media, and search.
- Grassroots partnerships with various local bars, venues and local events throughout New York to

New York State Gaming Commission  
Request for Applications for Mobile Sports Wagering Platform Providers  
Caesars Sportsbook

- provide a local touch to drive consumer engagement.
- Media and league partnerships
- Event activations at Turning Stone Resort and Casino, Yellow Brick Road Casino and Point Place Casino, all owed by the Oneida Indian Nation

*TV/Radio/Billboards:*

In New York's 10 media markets, we will buy local spot TV, radio, digital and outdoor heavily flighted throughout the NFL season, March Madness and year-round sporting events. We will also leverage our NFL, NBA, and NHL partnerships along with more than **CONFIDENTIAL INFORMATION BEGINS HERE** **CONFIDENTIAL INFORMATION ENDS HERE** of annual national TV support to drive revenue in New York. Our TV & Radio launch weights are **CONFIDENTIAL INFORMATION BEGINS HERE** 250 **CONFIDENTIAL INFORMATION ENDS HERE** TRPs (targeted rating points/week) against an A25-54 target demographic. In TV, our mix prioritizes programming between 6 p.m. and 1 a.m. In radio, we'll partner with top stations focusing on adults aged 21 years and older.

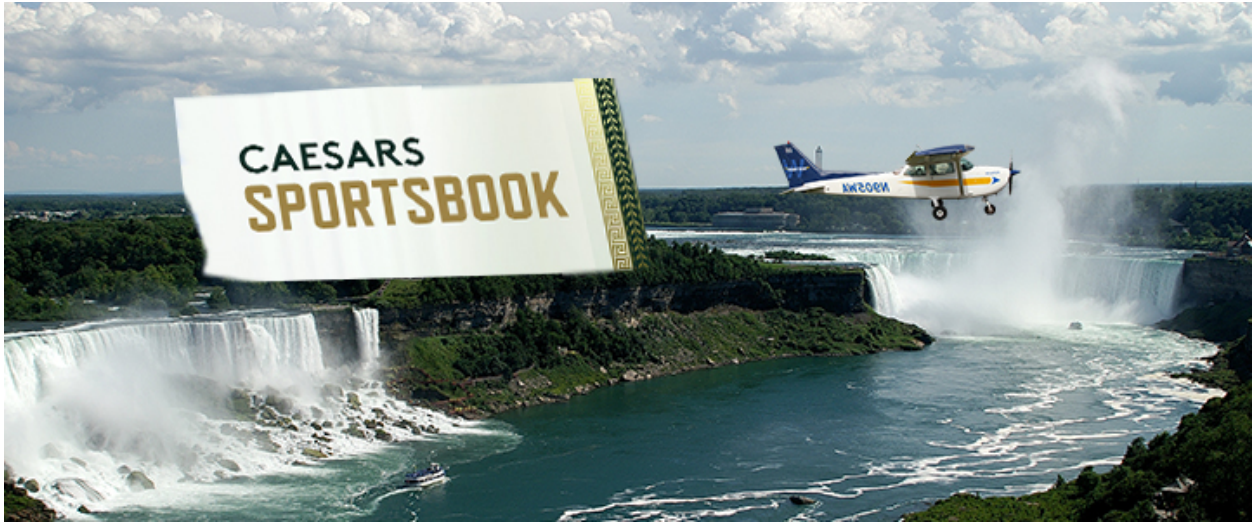
*Examples of New York Creative:*



New York State Gaming Commission  
Request for Applications for Mobile Sports Wagering Platform Providers  
Caesars Sportsbook



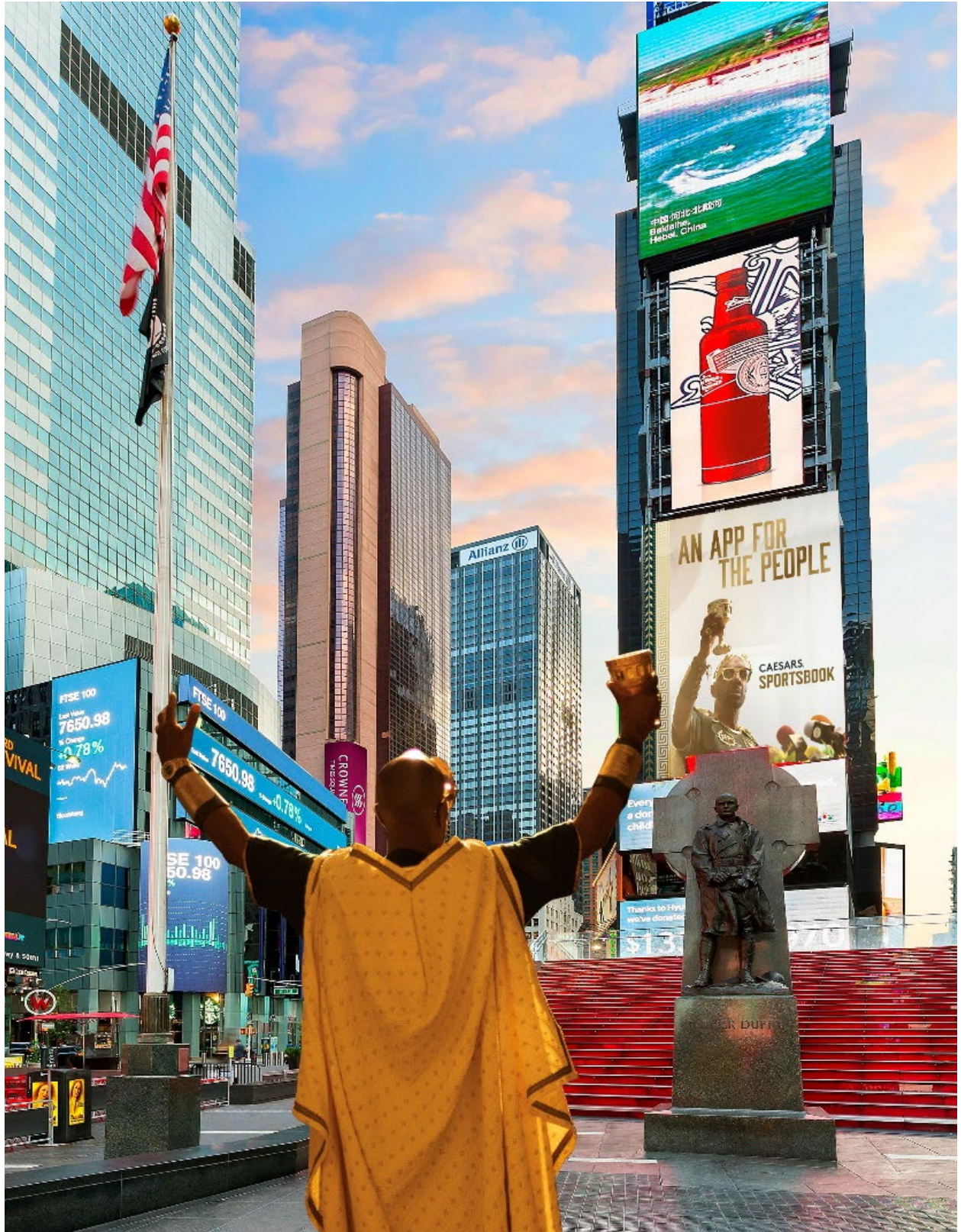
New York State Gaming Commission  
Request for Applications for Mobile Sports Wagering Platform Providers  
Caesars Sportsbook



New York State Gaming Commission  
 Request for Applications for Mobile Sports Wagering Platform Providers  
 Caesars Sportsbook



New York State Gaming Commission  
Request for Applications for Mobile Sports Wagering Platform Providers  
Caesars Sportsbook





New York State Gaming Commission  
Request for Applications for Mobile Sports Wagering Platform Providers  
Caesars Sportsbook





New York State Gaming Commission  
Request for Applications for Mobile Sports Wagering Platform Providers  
Caesars Sportsbook



*Grassroots Marketing:*

New York State Gaming Commission  
Request for Applications for Mobile Sports Wagering Platform Providers  
Caesars Sportsbook

We pride ourselves on relationships at a local level. We are part of the community and meet our customers where they spend their time. We use brand ambassadors to visit county fairs, bars and restaurants and other local events to educate attendees about sports betting and our product.



### Strategic Partnerships

Our partners are large affiliate relationships designed to drive customer acquisition at scale.

#### *CBS Sports:*

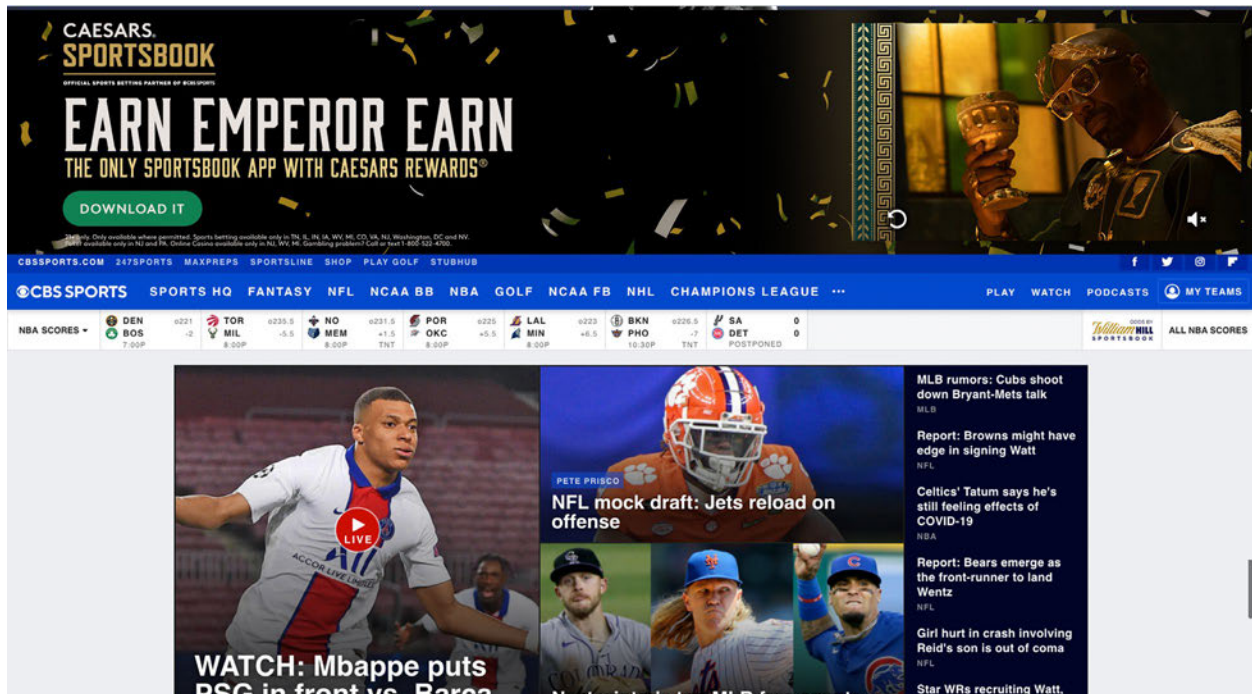
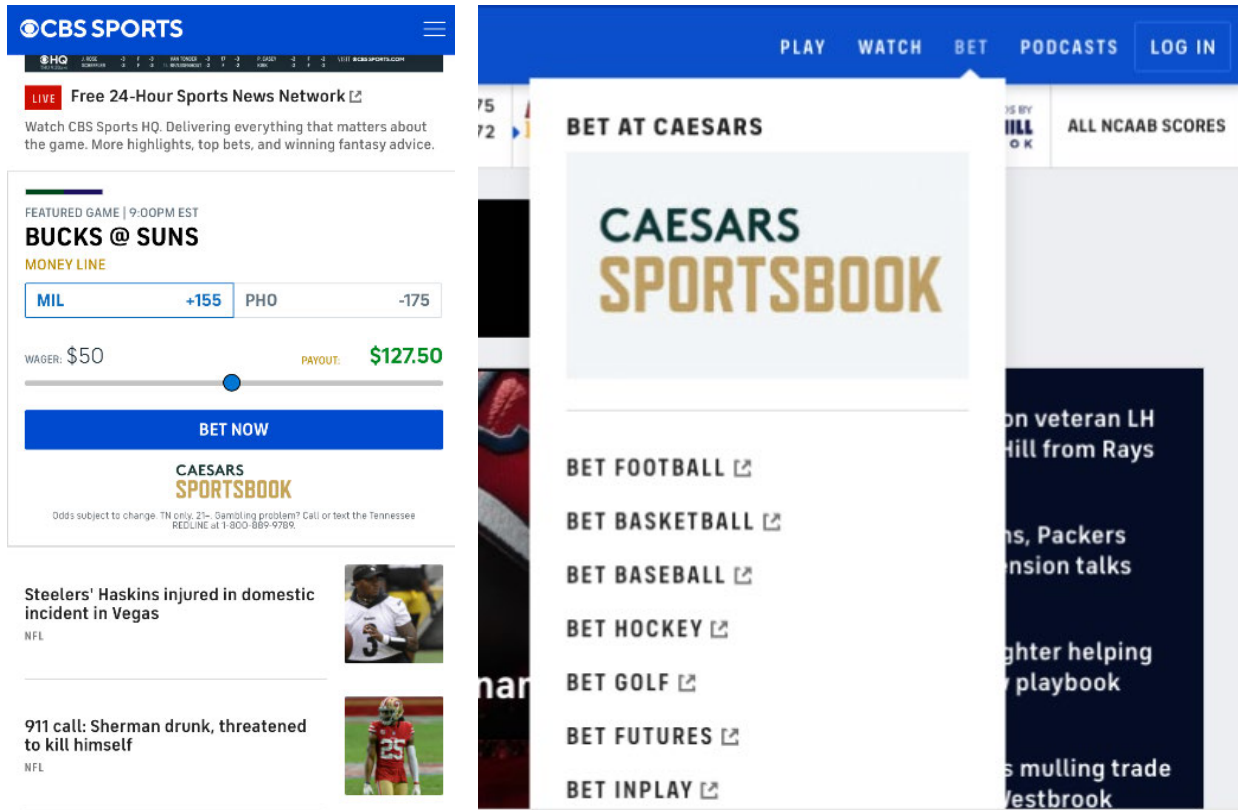
CBS Sports is the second-largest sports media property in the U.S., with more than **CONFIDENTIAL INFORMATION BEGINS HERE** **CONFIDENTIAL INFORMATION ENDS HERE** unique digital visitors per month across its platforms. Through CBSsports.com, SportsLine and CBS Fantasy, the CBS Sports database has about **CONFIDENTIAL INFORMATION BEGINS HERE** **CONFIDENTIAL INFORMATION ENDS HERE** active, engaged sports fans who are monthly users in New York. We have seen that season-long fantasy sports players, many of whom have been loyal to CBS Sports for years, will convert to sports betting customers.

Caesars is the exclusive sportsbook partner and wagering data provider across all CBS Sports platforms. Our partnership reimagines fan engagement through a unique integration of sports betting, media, product, and technology. The CBS Sports database allows us to immediately convert likely sports bettors in New York.

CBS digital properties in New York will display our betting odds on key pages, such as match up previews and scoreboards, with direct links to the Caesars Sportsbook app. For example, if a user in New York is reading a preview of a game between the Boston Bruins and the New York Rangers, he or she can place a bet by clicking directly from that page.

Through our partnership, Caesars invites local broadcasters to promote our mobile app, and invites on-air talent to play our free products and discuss the results. This engagement helps people unfamiliar with sports betting to become comfortable with different types of bets, the vernacular of sports betting and how to use the products.

New York State Gaming Commission  
Request for Applications for Mobile Sports Wagering Platform Providers  
Caesars Sportsbook



ESPN:

ESPN, like CBS Sports, features Caesars' sports betting apps and sportsbook odds and helps drive large scale customer acquisition. Caesars has a co-exclusive partnership with ESPN. Link integrations to

New York State Gaming Commission  
Request for Applications for Mobile Sports Wagering Platform Providers  
Caesars Sportsbook

Caesars' sports betting apps, geo-targeted to legalized sports betting states, will appear on ESPN.com web and mobile web and the ESPN Fantasy app. There are **CONFIDENTIAL INFORMATION BEGINS HERE**  
**CONFIDENTIAL INFORMATION ENDS HERE** registered ESPN users in New York.

ESPN is the pre-eminent brand in sports and the largest provider of sports content.



### Other Professional Sports League Partnerships That Benefit New York

#### National Football League:

Recently, Caesars became one of three Official Sports Betting Partners of the NFL in a multi-year deal. Caesars benefits from a variety of NFL intellectual property and asset rights, including the right to use league marks and logos in advertising and promotions. The agreement authorizes Caesars to offer NFL-themed free-to-play games and create sports betting content for NFL media platforms, including NFL.com and the NFL app. Caesars also has access to purchase television advertising within NFL games and to create NFL-branded experiences for customers.

Caesars shares the NFL's commitment to policies that protect the integrity of NFL games and protect consumers and together will collaborate in this mission, including information sharing and responsible gaming education.

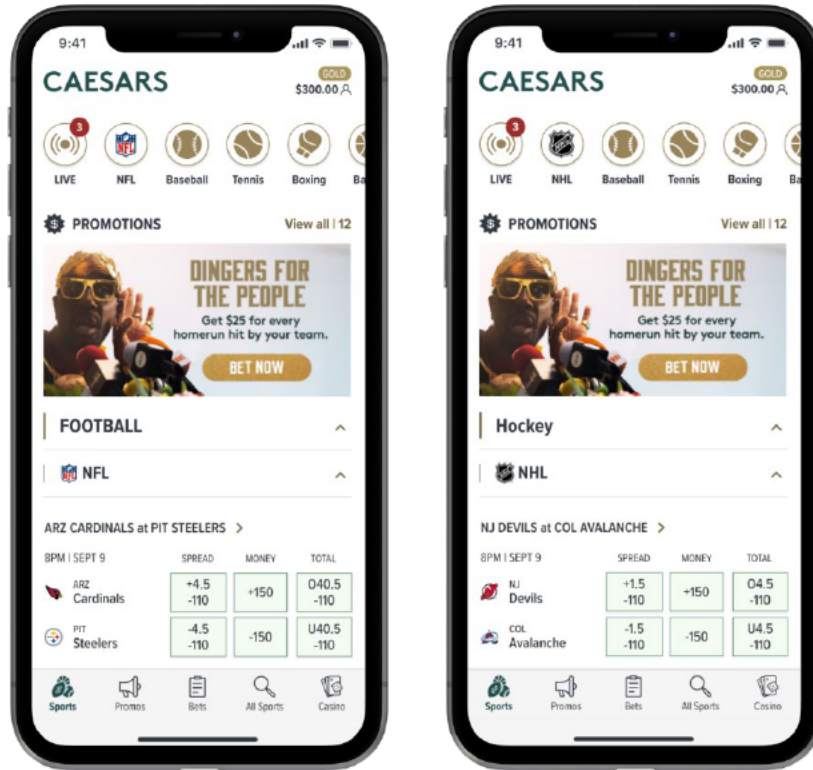
#### Use of Sports League Logos and IP:



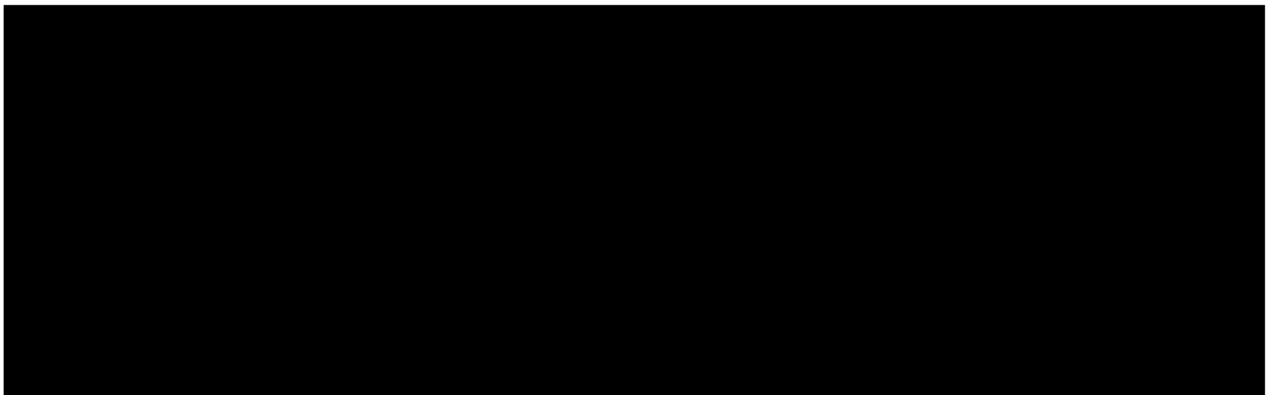
New York State Gaming Commission  
Request for Applications for Mobile Sports Wagering Platform Providers  
Caesars Sportsbook

In addition to rights under our official partnerships with MLB, NBA, NHL, and NBA, we are permitted to use NFL team and league logos on our app.

Examples of our use of league and team logos:



**CONFIDENTIAL INFORMATION BEGINS HERE**



**CONFIDENTIAL INFORMATION ENDS HERE**

*Major League Baseball:*

Caesars is an “Authorized Gaming Operator” of MLB. Under this partnership, Caesars has the right to use MLB league and club marks and logos on our mobile platform and in retail sportsbooks. Caesars also utilizes MLB’s official league data and collaborates with the league on integrity practices.



*National Basketball Association:*

Caesars is an official partner of the NBA. Under this partnership, Caesars receives significant media assets across NBA digital channels that will benefit the New York business and aid in customer acquisition. Caesars also has the right to use official NBA betting data and league marks across our mobile platforms and in-person sportsbooks.

As part of the partnership, Caesars and the NBA collaborate on best-in-class practices to protect the integrity of NBA games.

*National Hockey League:*

Caesars has teamed with the NHL to become an official sports betting partner. This allows us to advertise on the NHL's website and other digital platforms, as well as use official logos and official league data.

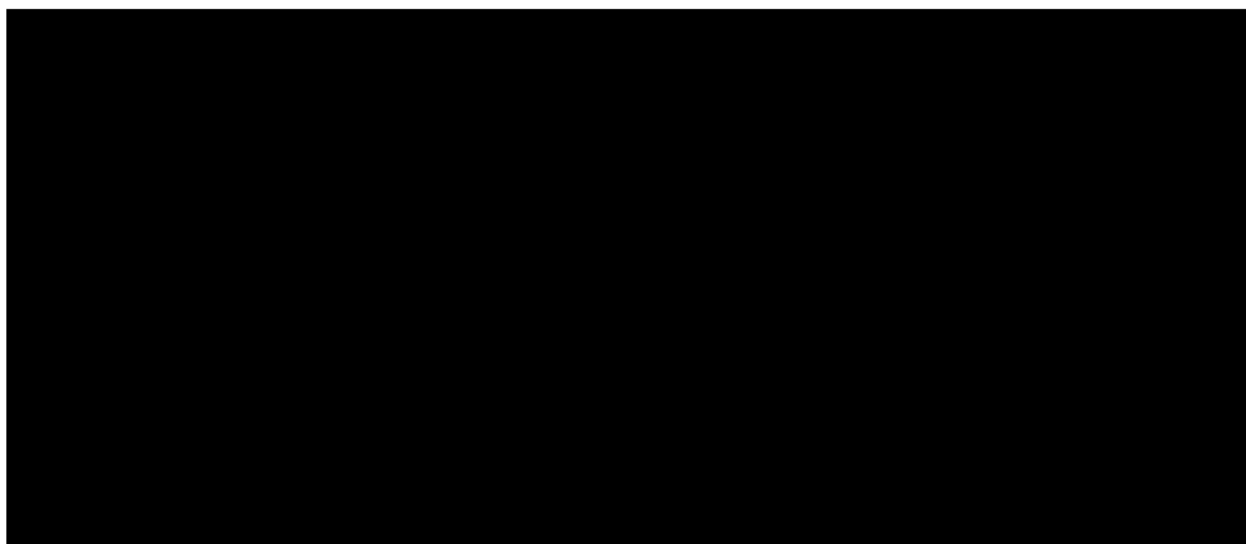
Partnerships with professional sports leagues allow us to reach millions of sports fan and potential bettors. As official partners, we can leverage that status to draw bettors away from illegal operators.



**Player acquisition models & marketing technology**

Caesars Sportsbook has access to the largest rewards database in the gaming industry, with more than 60 million customers, a deep bench of sports betting behavior and knowledge, and an understanding of what it takes to successfully launch in new markets.

We begin our player acquisition models by establishing clear key performance indicators (KPIs): aided and unaided brand awareness numbers, number of new customers (first-time depositors or FTDs), revenue and market share targets. We then model our media spend based on our market share target and launch direct response, localized programs, and targeted marketing journeys to drive customers to register, download and wager. In the sample marketing funnel below, we use media spend to drive upper funnel awareness and consideration and then use a combination of lower funnel "performance" spend, technology, and promotions to encourage customers to convert and then stay with us.



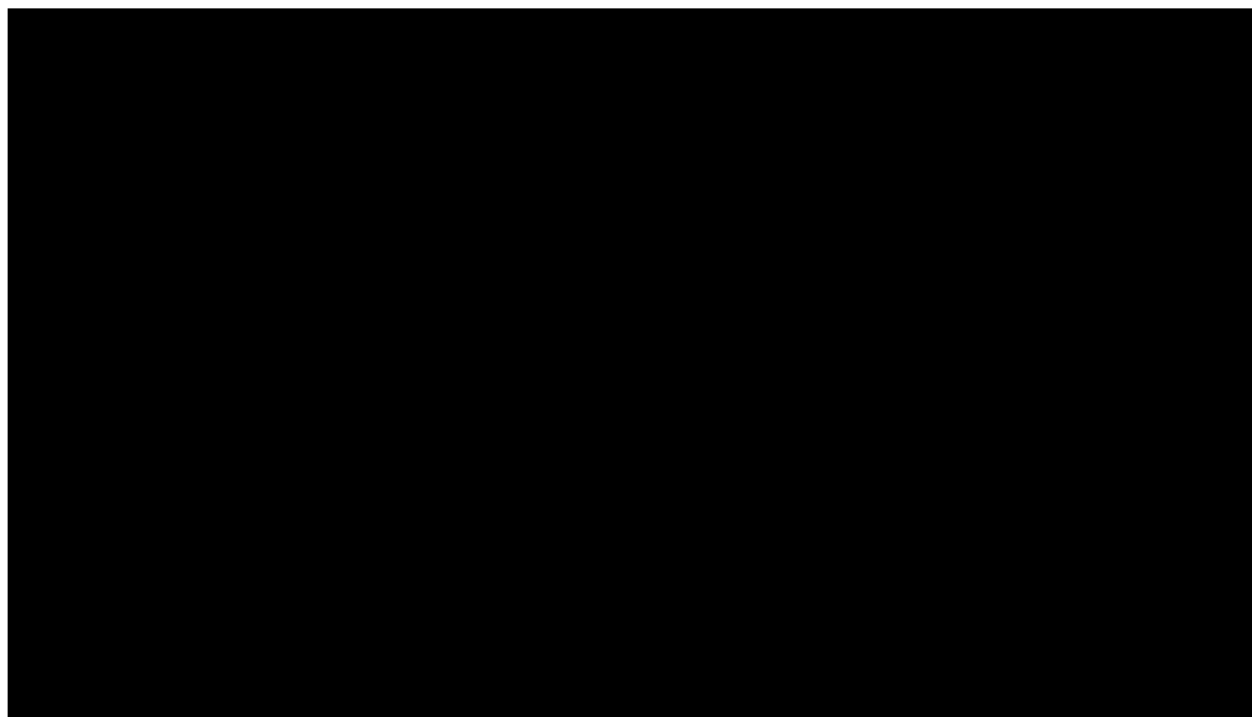


By channel, by vendor, by state numbers (FTDs, CPAs, total spend) are pulled and optimized weekly, with an eye towards optimizing mix and potentially reallocating funds to the highest performing channels and/or times of year. We use a suite of measurement and marketing technology tools to track and ultimately optimize our overarching spend and log learnings for future modeling improvements.

### **Marketing Technology**

Caesars uses marketing technology to address fans who show interest in betting but do not initially download the application or provide their email address. These customers are appropriately segmented so Caesars can provide additional creative and test new offers. Other capabilities include propensity modeling (finding like-minded fans), affiliate marketing and the use of CRM (using marketing technology tools to maximize player experience).


Caesars' data warehouse provides the team with full player value metrics and a proprietary predictive lifetime value ("LTV") tool based on more than 20 key performance indicators to determine marketing return on investment matching LTV against cost per acquisition ("CPA").



### **Player loyalty programs and promotions**

#### **Caesars Rewards**

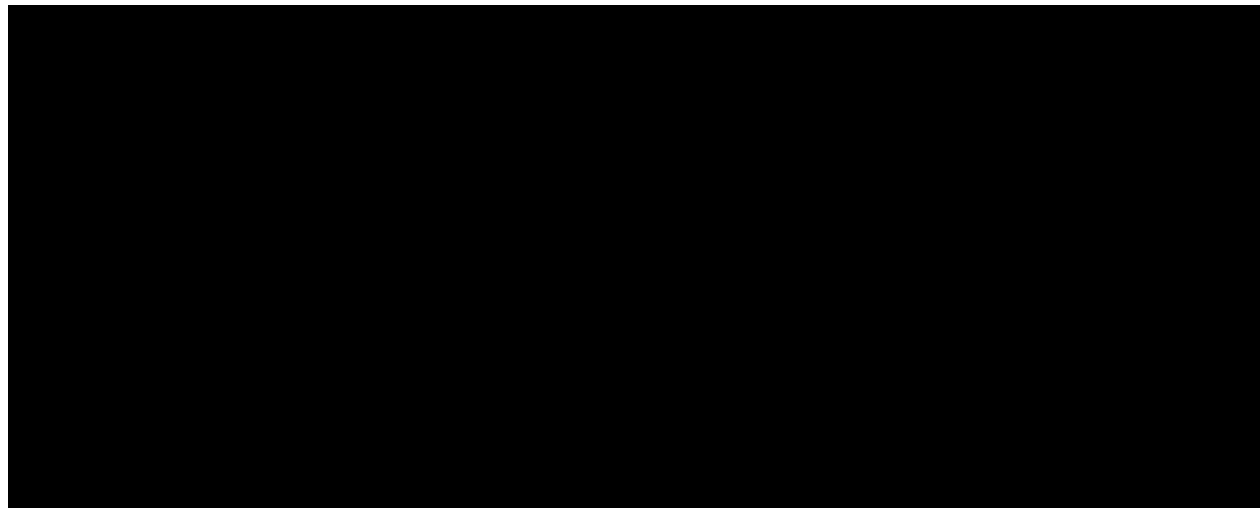
With Caesars Rewards, Caesars stands alone in the sports betting landscape. It is the gaming industry's largest and oldest loyalty program and is widely regarded as the best in class by our customers as well as industry and loyalty publications like Loyalty 360, USA Today, and the Freddie Awards. There is no other operator in the world that can match the depth and reach of the Caesars Rewards program. With Caesars Rewards, bettors access an empire; an empire where they are always a VIP and can be rewarded with free bets, special bonuses, tickets to sports games, or hotel stays on us.

The program consists of 1) the richest database of consumer gaming behavior with over 60 million members worldwide, 2) existing loyal relationships with **CONFIDENTIAL INFORMATION BEGINS HERE** 

**CONFIDENTIAL INFORMATION ENDS HERE** New Yorkers, and 3) the most sophisticated data science platforms that consistently drive immediate returns.

*Exhibit Caesars Database Counts – New York:*

**CONFIDENTIAL INFORMATION BEGINS HERE**



**CONFIDENTIAL INFORMATION ENDS HERE**

### **Program Structure**

There are two ways customers can earn benefits with Caesars Rewards.

The first way customers earn benefits with Caesars Rewards is that they receive personalized offers like free bets, hotel rooms, dining credit and other VIP experiences, as well as Reward Credits (cash back). Customers can then use these rewards at their discretion to do the things they love. Our ability to target these rewards through a proprietary process of personalization, segmentation, and optimization allows us to feel confident that our customers are getting offers they value, when they want them, through mediums they want to engage.

The second way customers earn benefits with Caesars Rewards is through a traditional tiering system. We have six tiers that customers progress through and at each tier our customers are entitled to more significant benefits. For example, a gold customer (our lowest tier) is entitled to personalized offers, special Caesars Rewards pricing on hotel rooms, and a free bet on their birthday online. Seven Stars customers (our highest tier) can enjoy free hotel rooms, no resort fees, free valet parking, a Seven Stars weekend retreat including airfare and entertainment, and free stays with our partners, amongst other perks.

In addition to the offers and tier benefits our customers enjoy, Caesars Rewards also has several meaningful partnerships that can enhance our customers' experiences: the NFL, Atlantis Paradise Island in the Bahamas, Wyndham Resorts, Hertz Rental Cars, Norwegian Cruise Lines, Vivid Seats, 1-800 Flowers and more allow our customers to extend their membership benefits beyond our sportsbook or casinos.

Caesars Rewards offers portability across its vast network. A guest who earns Seven Stars in Las Vegas receives Seven Stars treatment across the rest of the Caesars portfolio. This delivers our program's key competitive advantage: our customers have nationwide opportunities to be treated like a VIP. A VIP in New York is a VIP everywhere.

## **Player Reinvestment**

Caesars invests in its players. Customers deserve better – they deserve an experience that is fun and rewarding to get in on and enjoy the action. We offer the most ways to play, live betting and promotions. Furthermore, with our legacy in gaming and sports betting, consumers know that they can trust us.

We like our customers to get to know us and can use marketing technology and player data to tailor messaging and promotional strategies depending on where a customer is in their lifecycle.

1. In their early days, we show customers who we are and how betting sports can be fun. We offer a wide range of deposit matches, boosts, and bet and gets to drive sampling and foster understanding and familiarity with sports betting.
2. After they've gotten started, we can provide targeted offers based on their previously defined sports preferences
3. Once customers have matured with us, we can really speak to their preferences. We serve relevant offers and ads and avoid those that aren't meaningful to the customers.

Caesars is known for innovative offers that appeal to local sports fans and bettors. We create experience that are fun to participate in and are simple in their terms and provisions. Our promotions – and teams – are built and managed on a state-by-state basis – meaning we will invest the time and resources to understand the New York customer and craft specific and relevant offers and activations for local users. Our New York field marketing team will manage sports partnership relationships, identify activation opportunities with local partners, execute regional offers and implement brand programming in partnership with the promotions state lead. The New York Promotions Lead is responsible for optimizing results by creating and executing locally oriented promotions, and then optimizing player performance based on data insights.

We know which incentives sports bettors want and how to offer these responsibly. Our vast experience in many jurisdictions around the country has led to the fine-tuning of promotions and rewards that are best received by sportsbook patrons for cross-selling products, reactivation, and aspirational loyalty programs.

## **Efforts to be undertaken to convert customers from unlicensed wagering channels to legal wagering in the state**

Caesars has at its disposal the tools needed to convert customers to legal wagering. First and foremost, Caesars Rewards is the reason to believe. The more that customers use our legalized platform, the more they can earn back in rewards that are redeemable in state and across the country. Who doesn't want to be treated like Caesar?

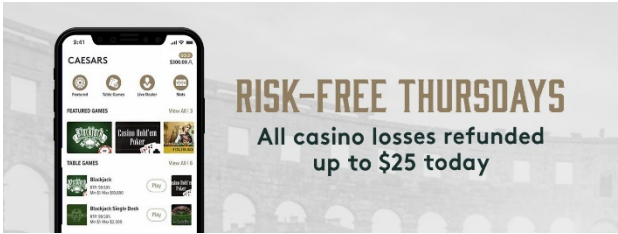
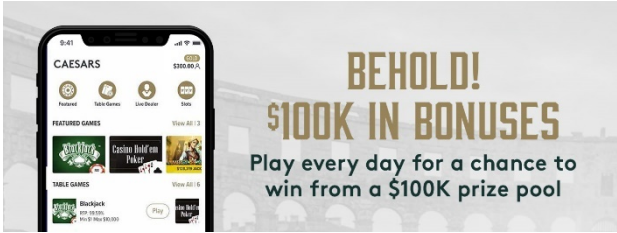
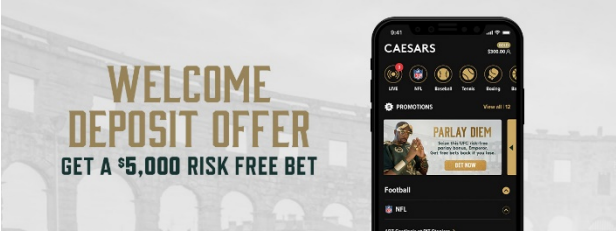
We will leverage our partnerships with the leagues, media networks, and sports teams to tell our story and introduce the value proposition of betting with a licensed sportsbook. We do not advertise with any partner that accepts advertising from an illegal or offshore sports betting organization. Once a customer expresses interest, we can use marketing technology to find, keep, and retain that customer in a way that unlicensed partners cannot.

Last, we will deliver a better customer experience – from technology to product to promotions to customer service – which will encourage customers to stay with us.

**The Applicant shall provide examples and samples of marketing, advertising, and promotional activities recently undertaken in other jurisdictions by each of the proposed Operators in the Application.**

*Samples of marketing, advertising, and promotions activities in other jurisdictions:*

**In App Promo Banners**



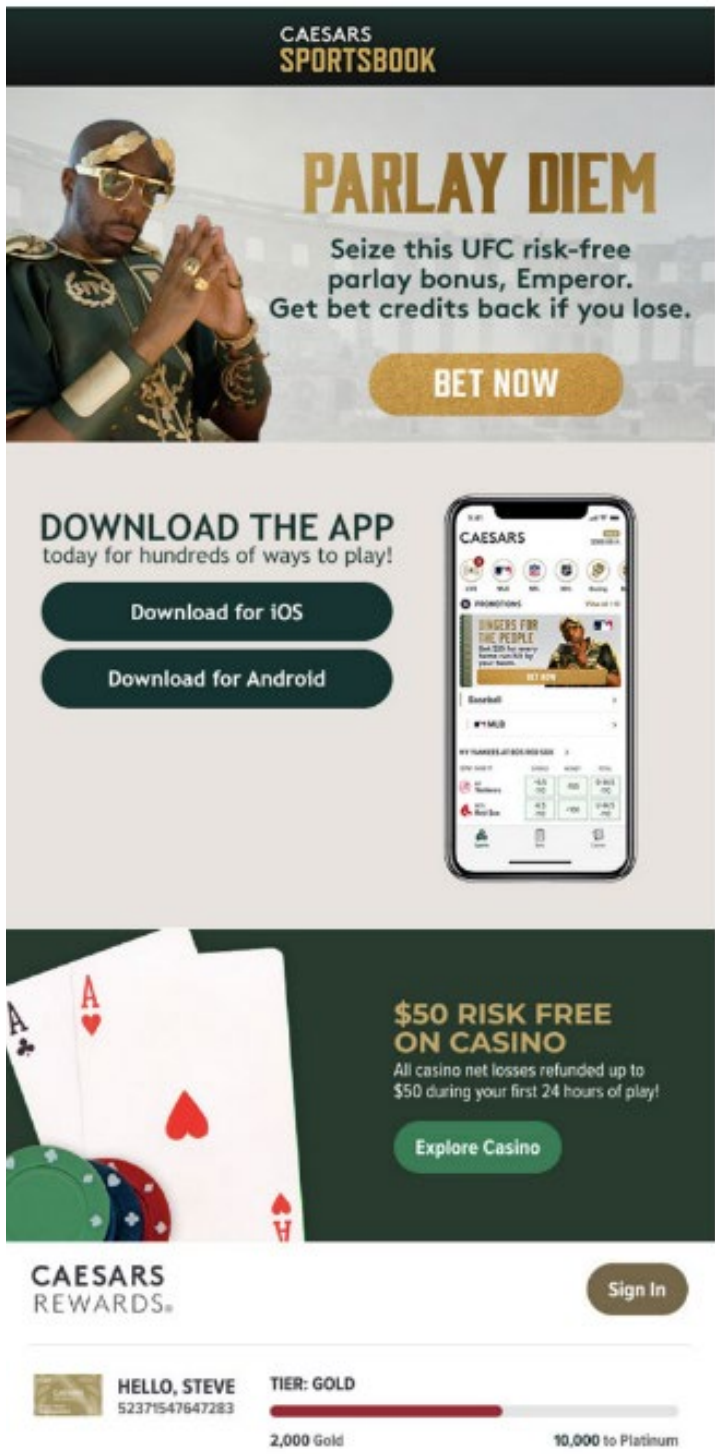
Out of Home



Banner Ads



## Retention Emails



**CAESARS SPORTSBOOK**

**PARLAY DIEM**  
Seize this UFC risk-free parlay bonus, Emperor. Get bet credits back if you lose.

**BET NOW**

**DOWNLOAD THE APP**  
today for hundreds of ways to play!

Download for iOS  
Download for Android

**\$50 RISK FREE ON CASINO**  
All casino net losses refunded up to \$50 during your first 24 hours of play!

**Explore Casino**

**CAESARS REWARDS** [Sign In](#)

**HELLO, STEVE**  
52371547647283

**TIER: GOLD**

2,000 Gold  10,000 to Platinum

# **Exhibit A – AWI – NV Certificate of Existence**



# SECRETARY OF STATE



## CERTIFICATE OF EXISTENCE WITH STATUS IN GOOD STANDING

I, Barbara K. Cegavske, the duly qualified and elected Nevada Secretary of State, do hereby certify that I am, by the laws of said State, the custodian of the records relating to filings by corporations, non-profit corporations, corporations sole, limited-liability companies, limited partnerships, limited-liability partnerships and business trusts pursuant to Title 7 of the Nevada Revised Statutes which are either presently in a status of good standing or were in good standing for a time period subsequent of 1976 and am the proper officer to execute this certificate.

I further certify that the records of the Nevada Secretary of State, at the date of this certificate, evidence, **AMERICAN WAGERING, INC.**, as a DOMESTIC CORPORATION (78) duly organized under the laws of Nevada and existing under and by virtue of the laws of the State of Nevada since 08/02/1995, and is in good standing in this state.



IN WITNESS WHEREOF, I have hereunto set my hand and affixed the Great Seal of State, at my office on 07/27/2021.

*Barbara K. Cegavske*

BARBARA K. CEGAVSKE  
Secretary of State

Certificate Number: B202107271866279

You may verify this certificate  
online at <http://www.nvsos.gov>

## **Exhibit B – AWI – NY-Good Standing**

STATE OF NEW YORK

DEPARTMENT OF STATE

Certificate of Status

I, ROSSANA ROSADO, Secretary of State of the State of New York and custodian of the records required by law to be filed in my office, do hereby certify that upon a diligent examination of the records of the Department of State, as of the date and time of this certificate, the following entity information is reflected:

**Entity Name:** AMERICAN WAGERING, INC.  
**DOS ID Number:** 5858528  
**Entity Type:** FOREIGN BUSINESS CORPORATION  
**Entity Status:** AUTHORIZED  
**Date of Initial Filing with DOS:** 10/16/2020

**Statement Status:** CURRENT  
**Statement Due Date:** 10/31/2022

No information is available from this office regarding the financial condition, business activity or practices of this entity.



WITNESS my hand and official seal of the Department of State,  
at the City of Albany, on July 29, 2021 at 09:45 A.M.

ROSSANA ROSADO, Secretary of State

A handwritten signature in black ink that reads "Brendan C. Hughes".

By Brendan C. Hughes  
Executive Deputy Secretary of State

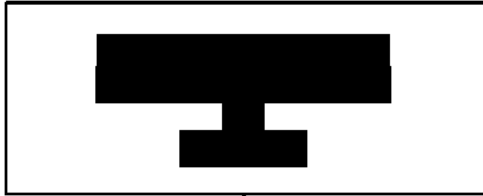
Authentication Number: 100000166316 To Verify the authenticity of this document you may access the  
Division of Corporation's Document Authentication Website at

# **Exhibit C – Caesars Entertainment Org Chart**

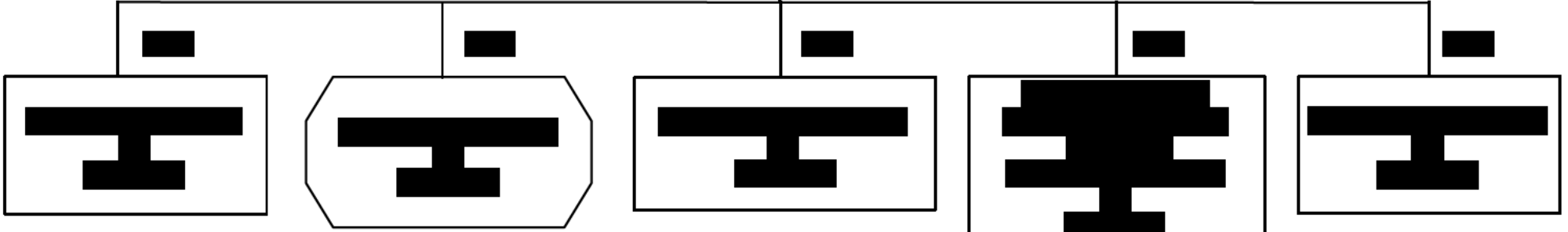
[REDACTED]

[REDACTED]

[REDACTED]

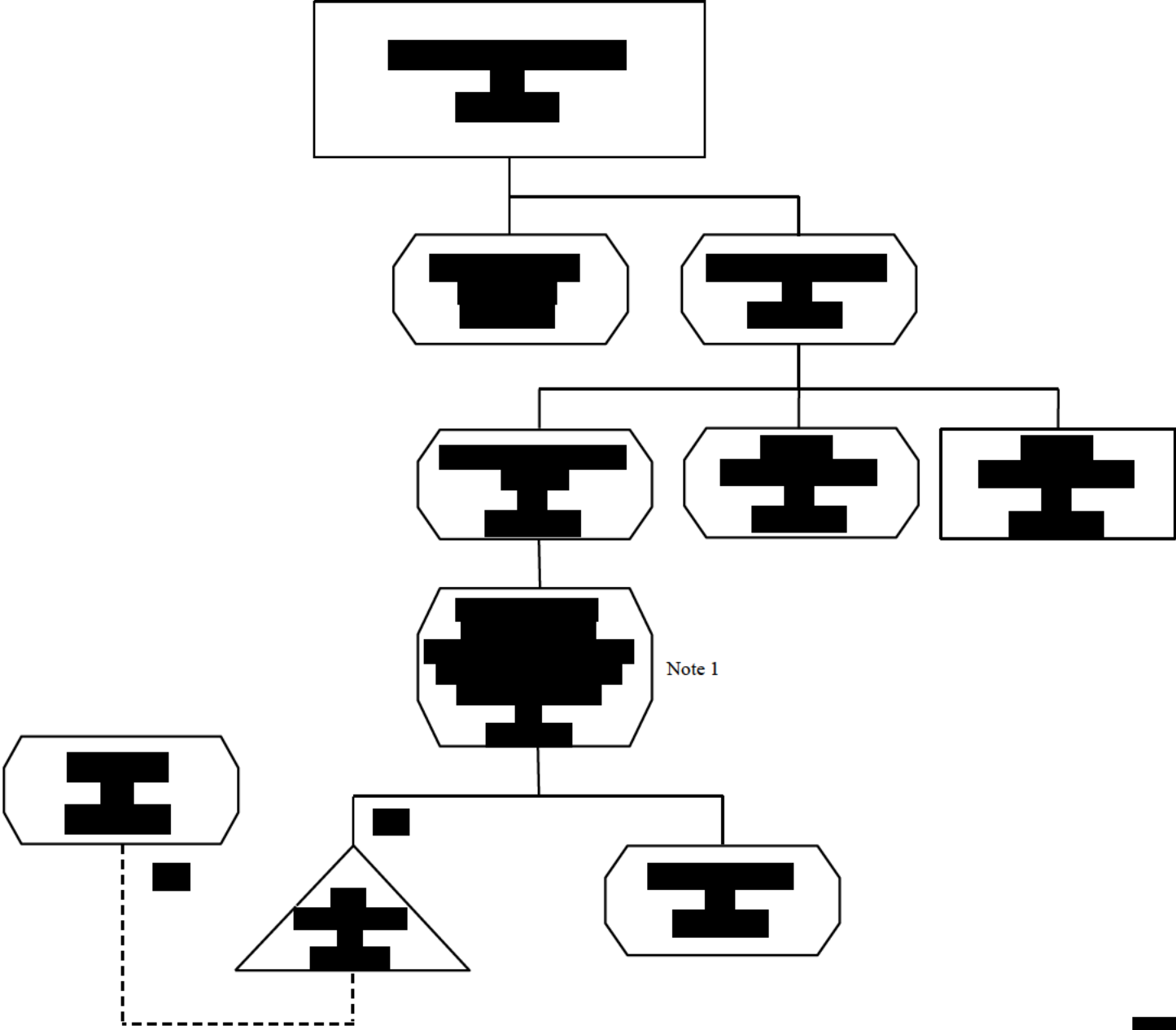


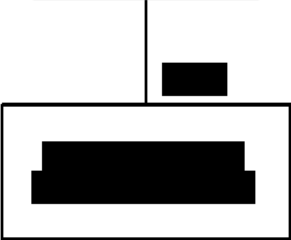
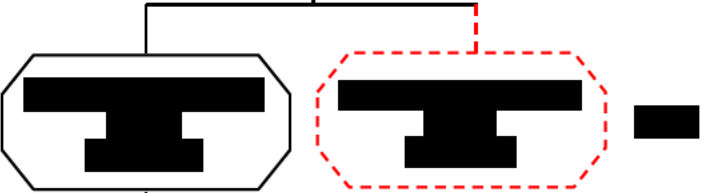
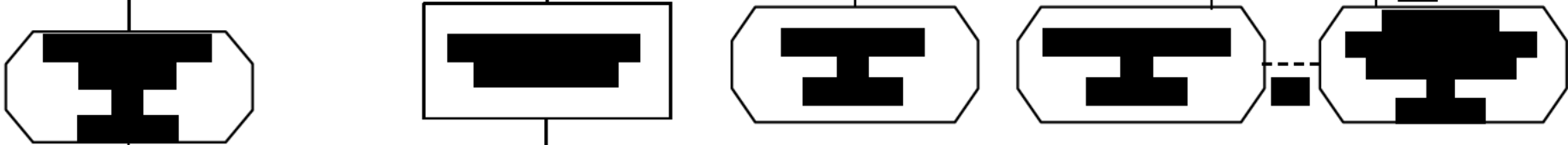
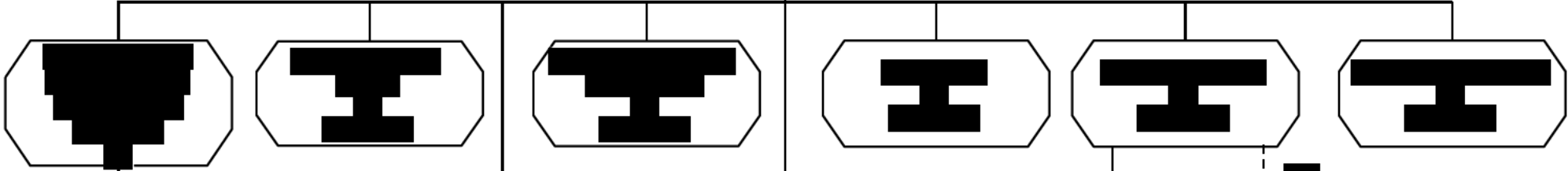
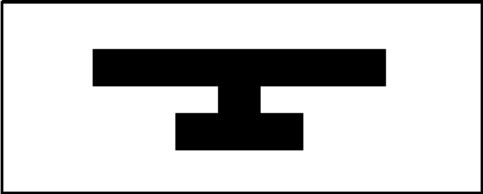
[REDACTED]

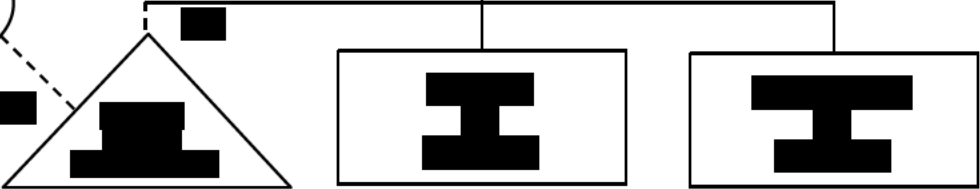
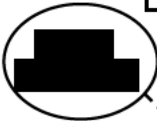
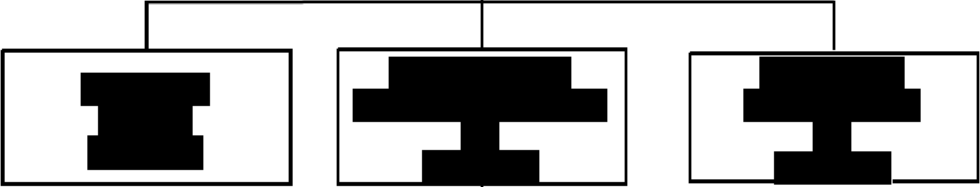
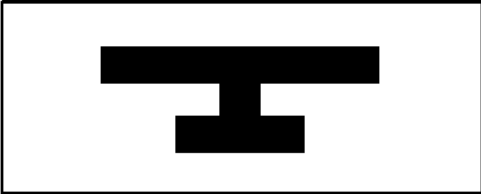


[REDACTED]

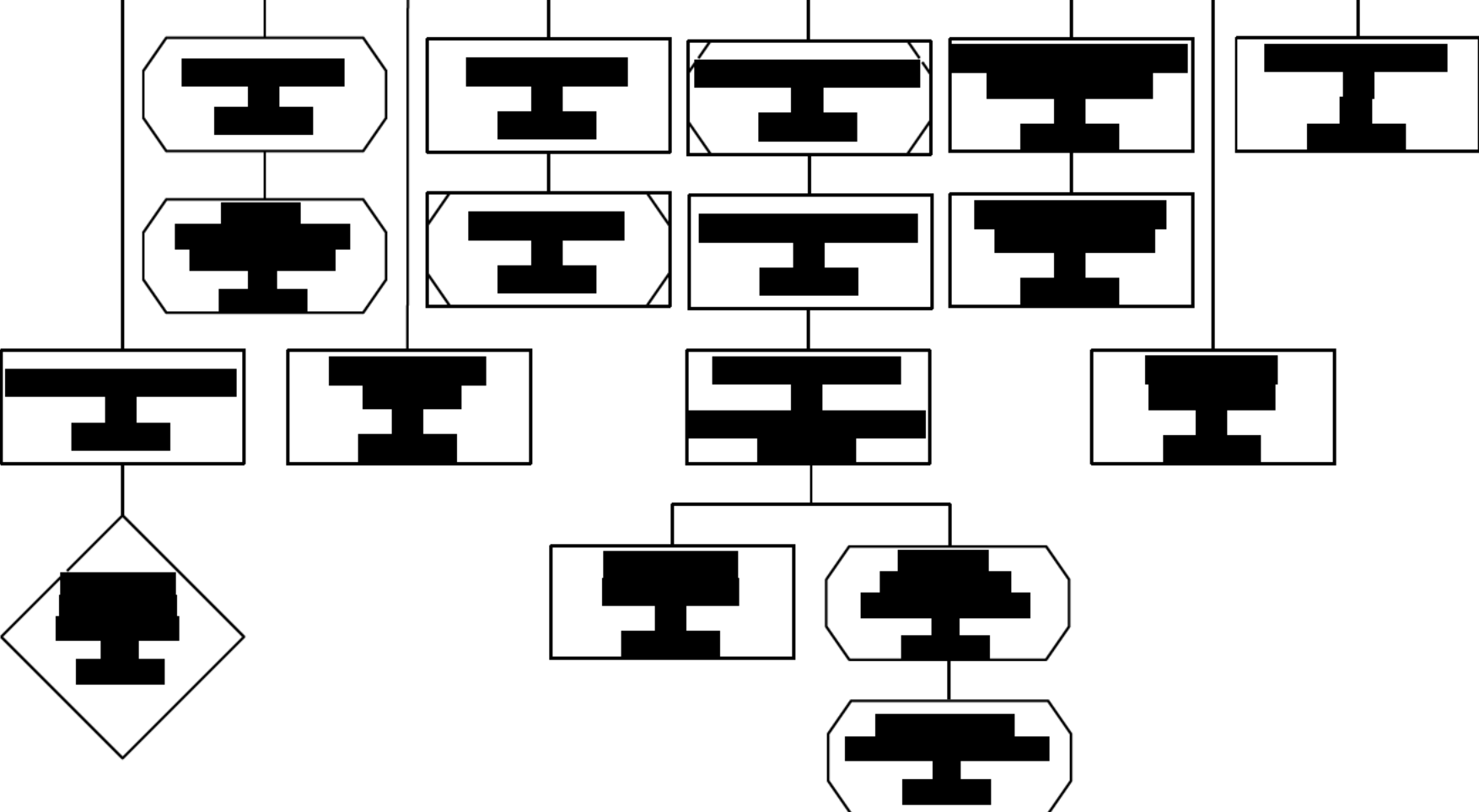
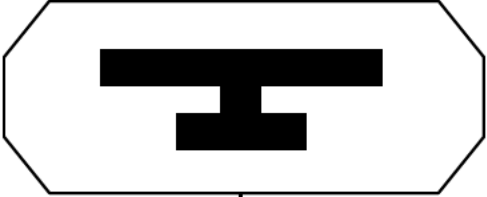
[REDACTED]

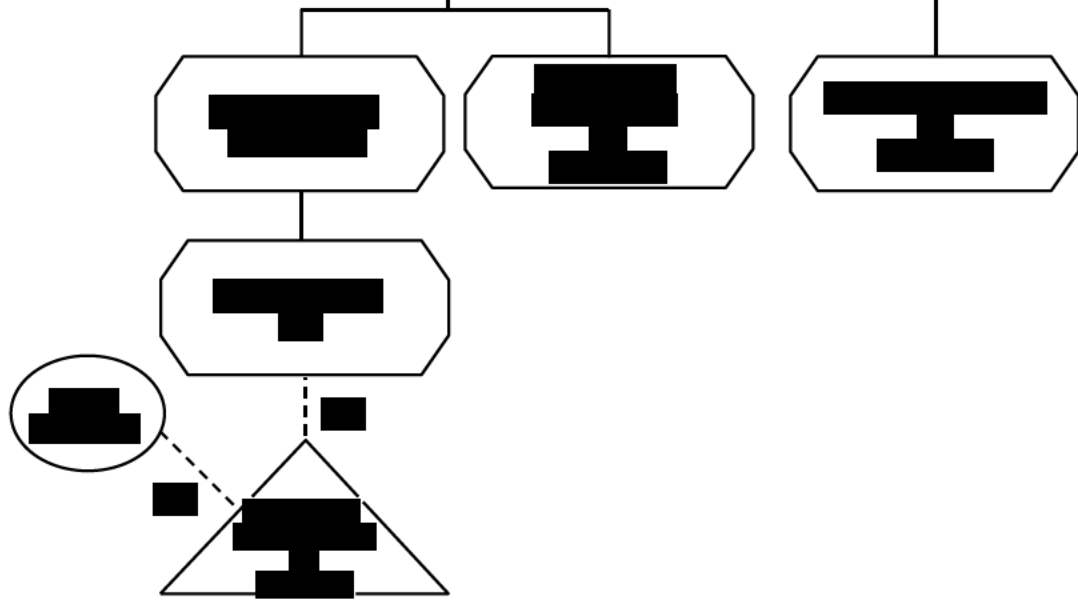
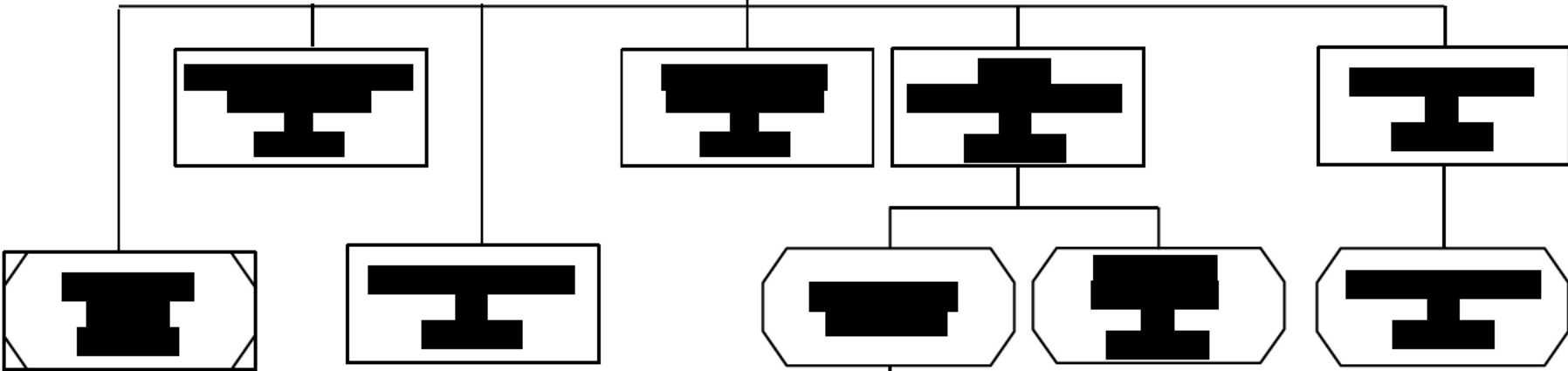
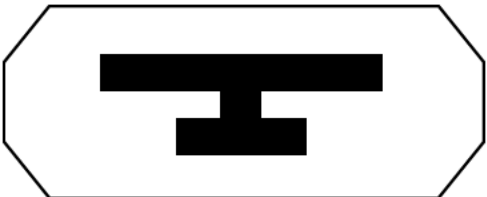


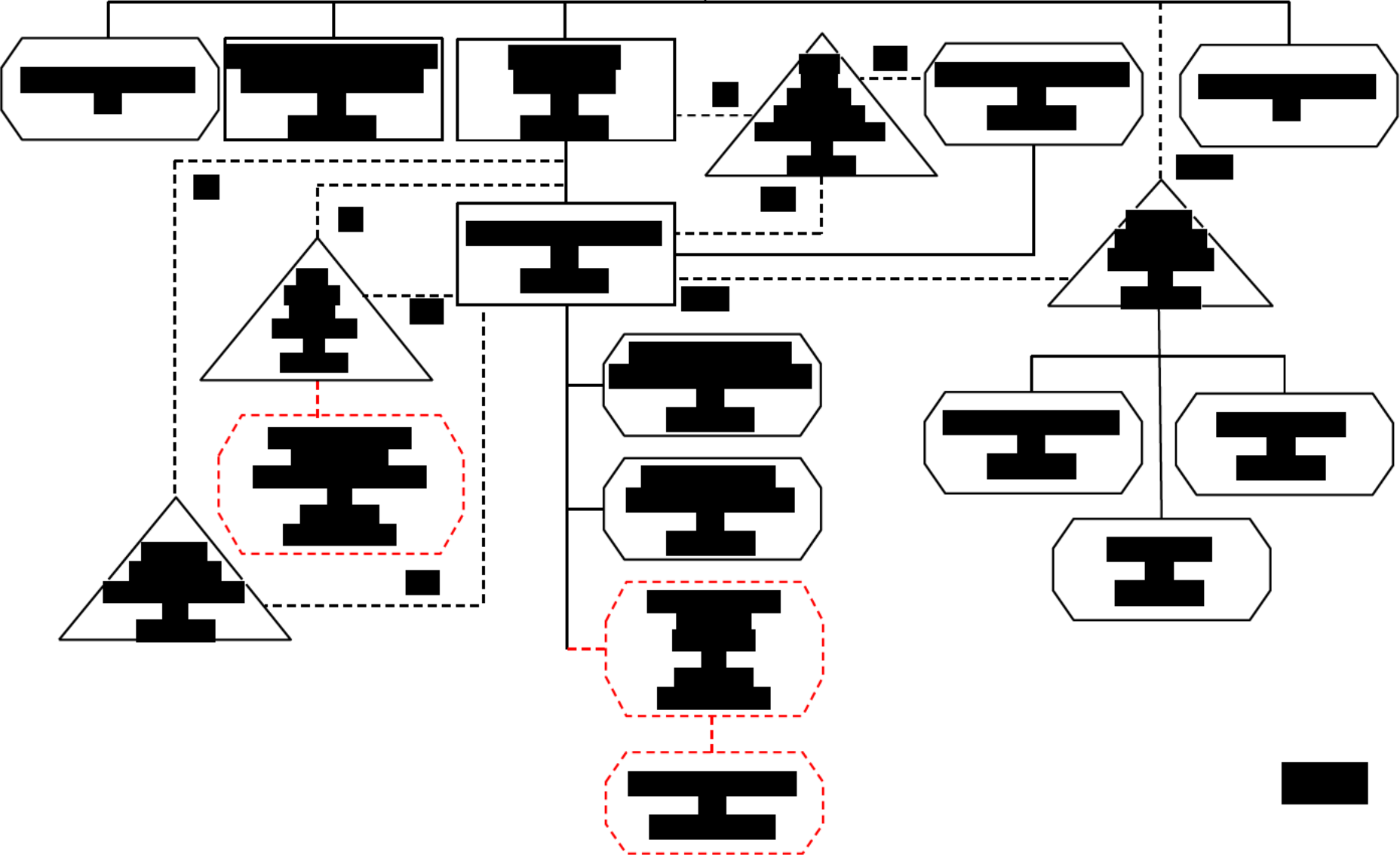
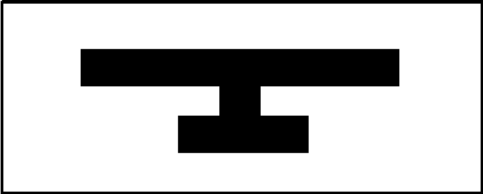


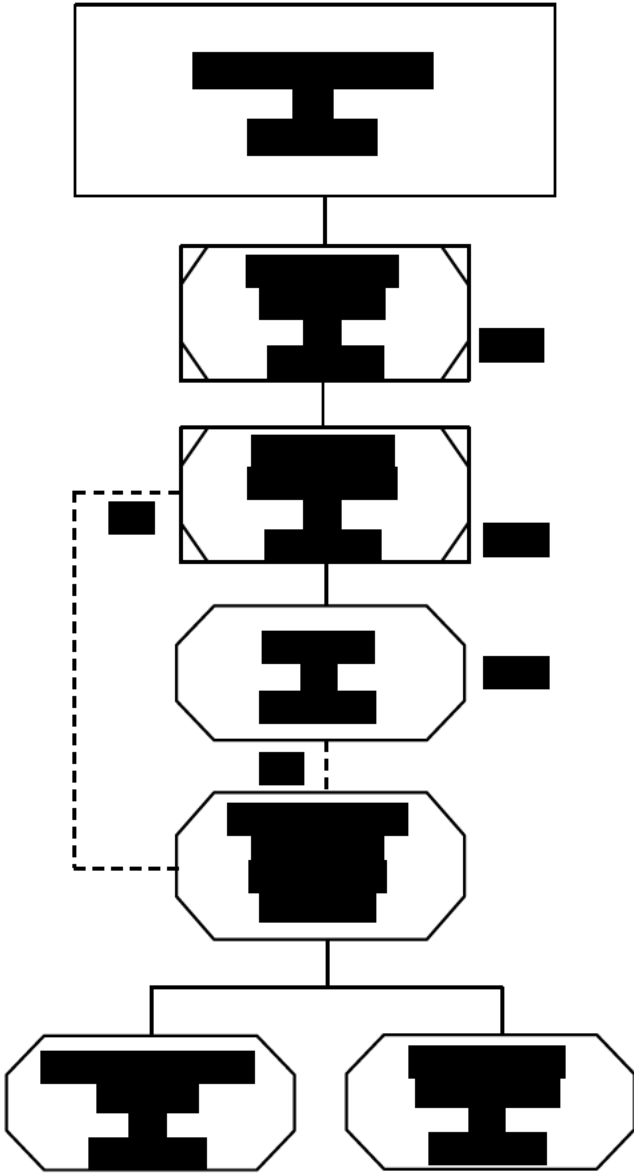


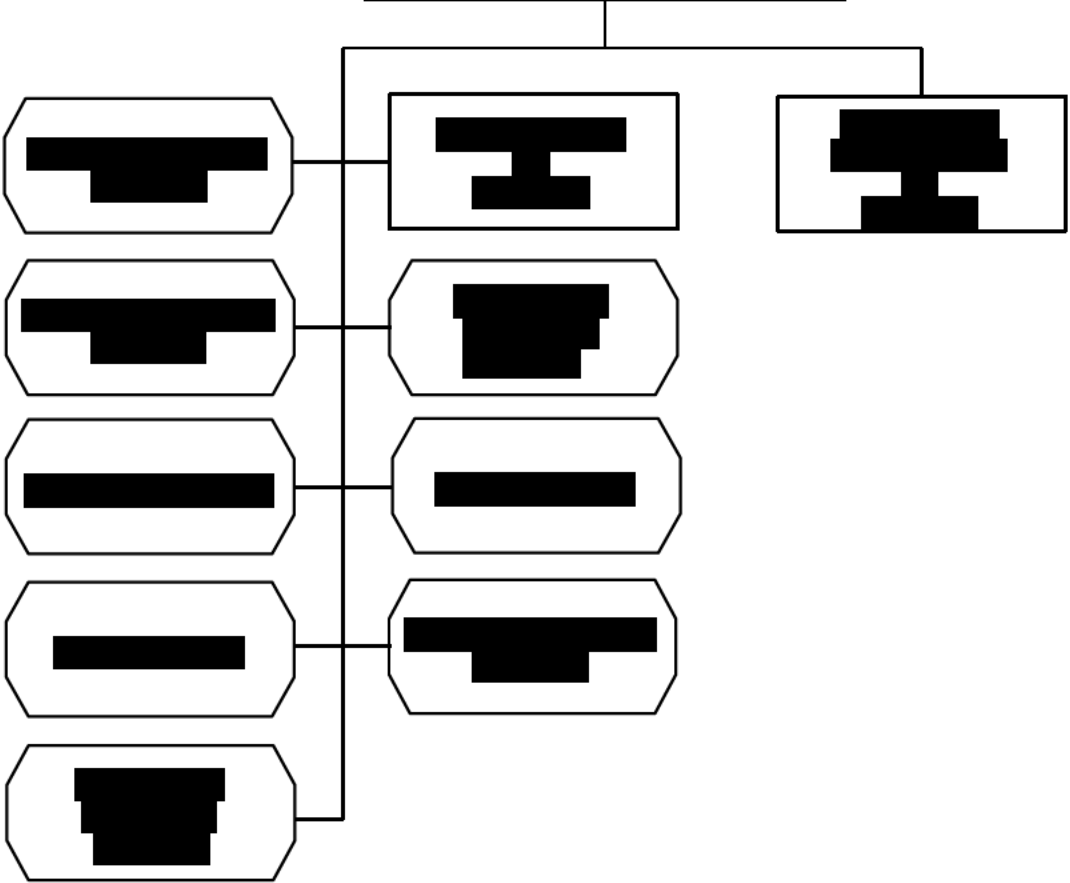
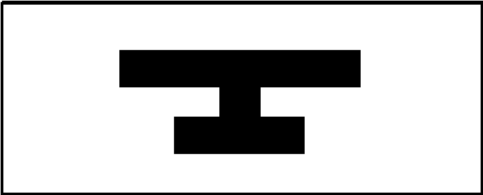


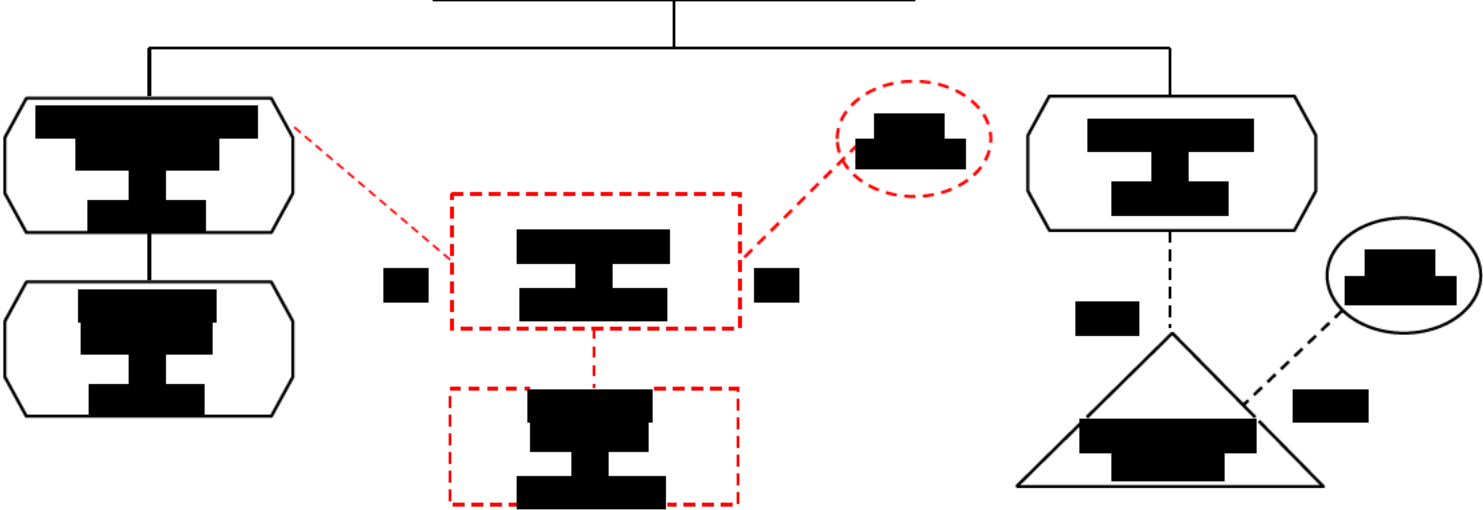
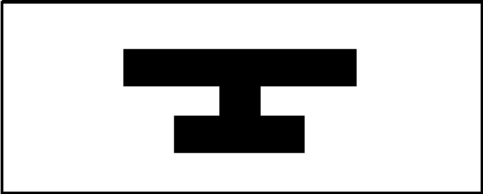


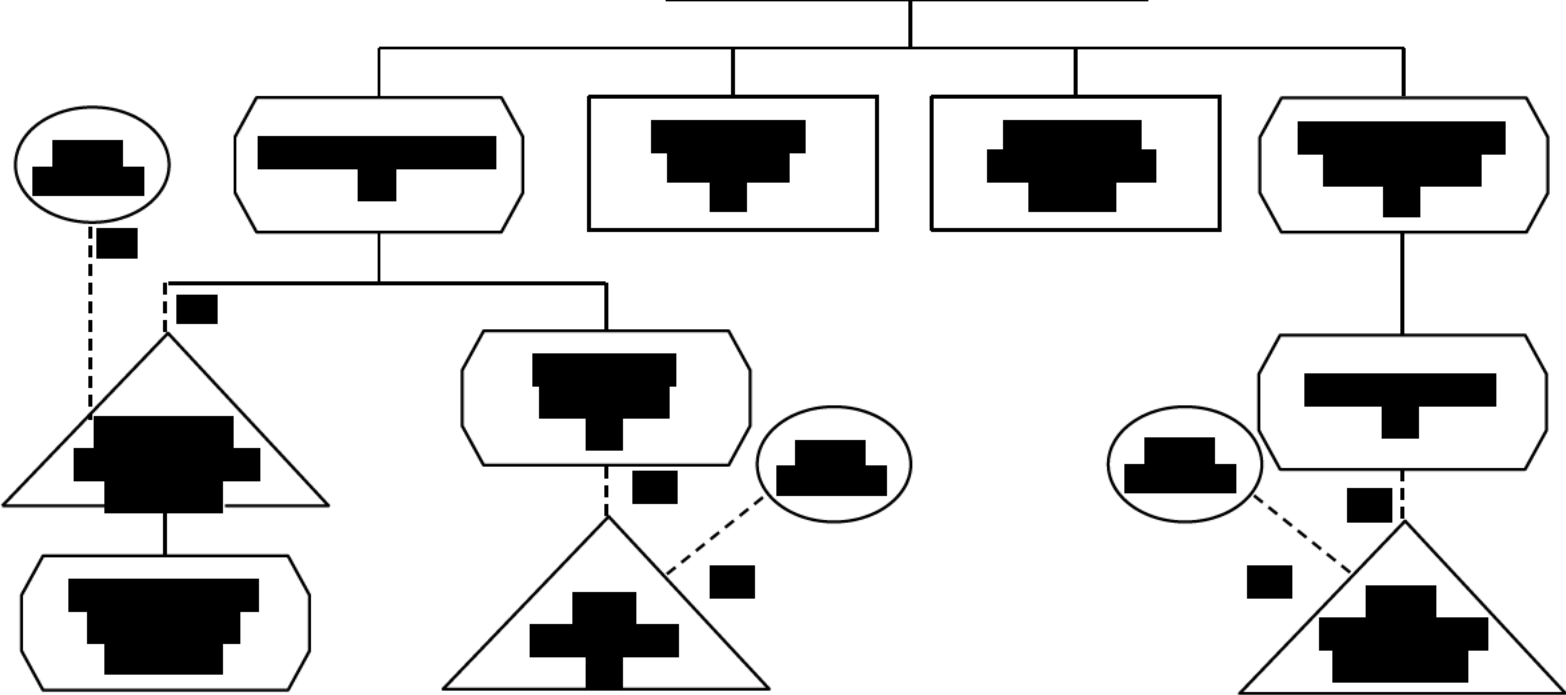
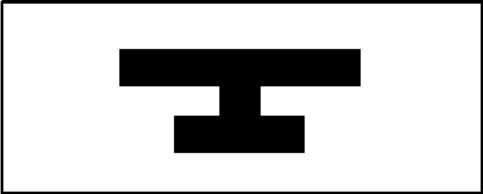


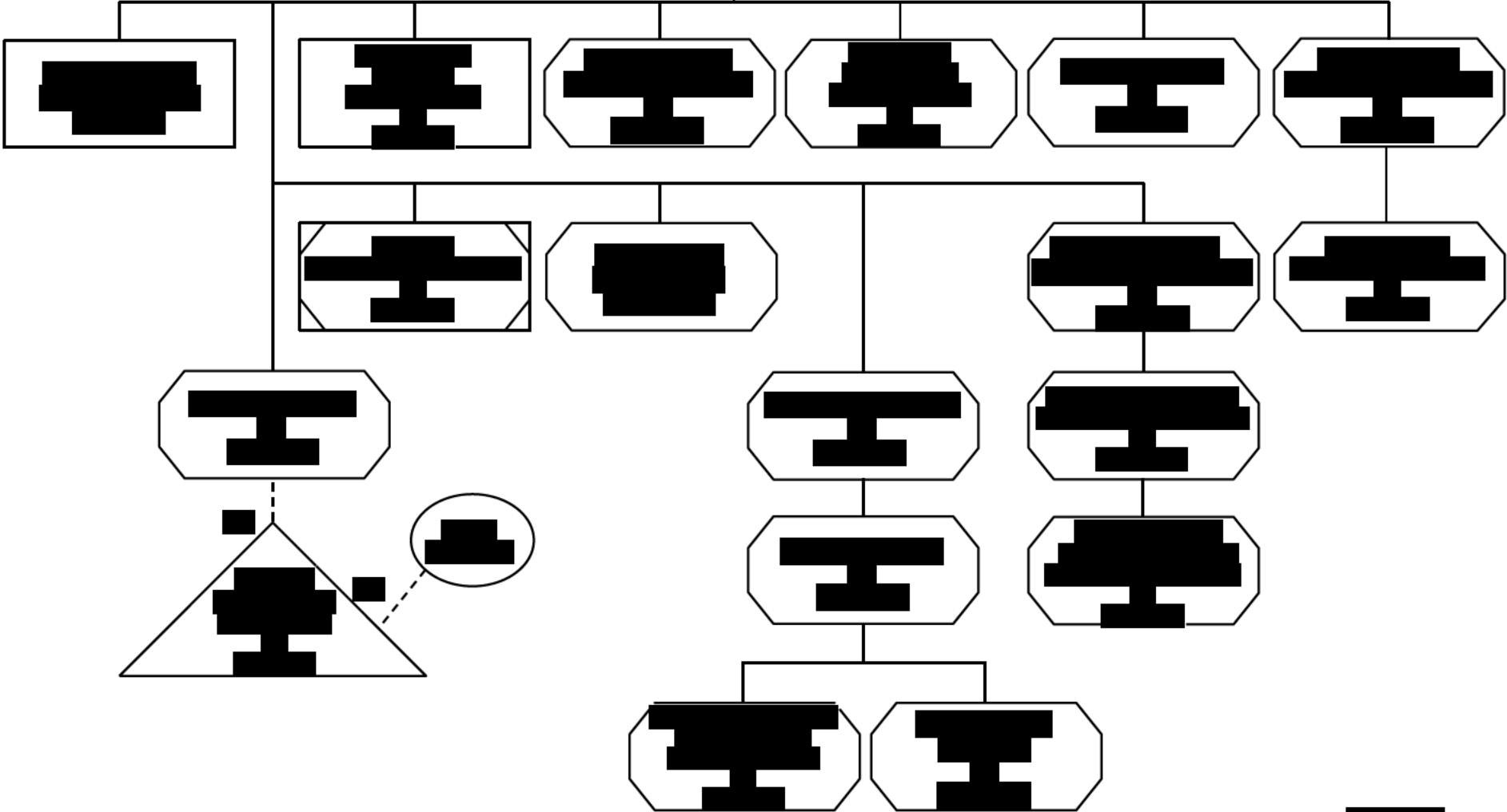
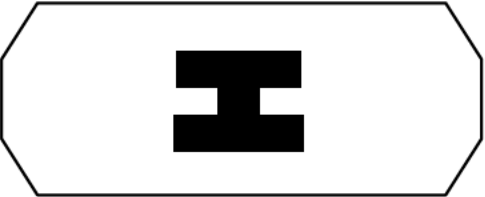




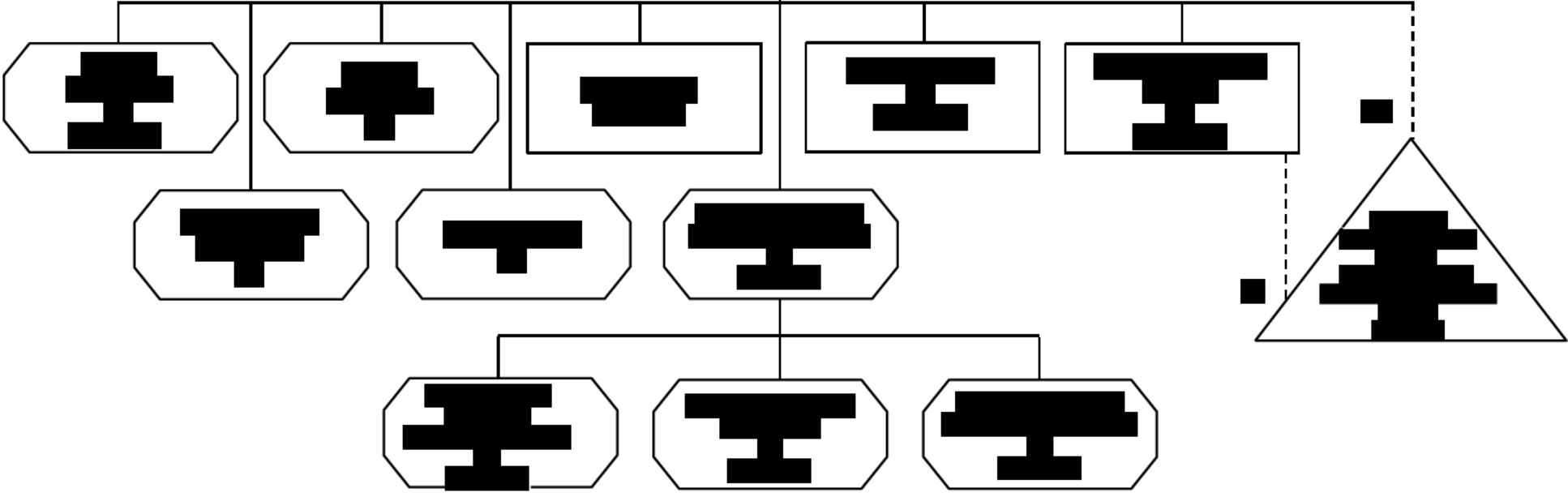
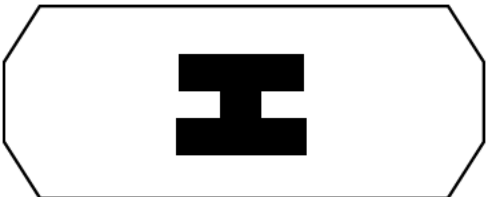


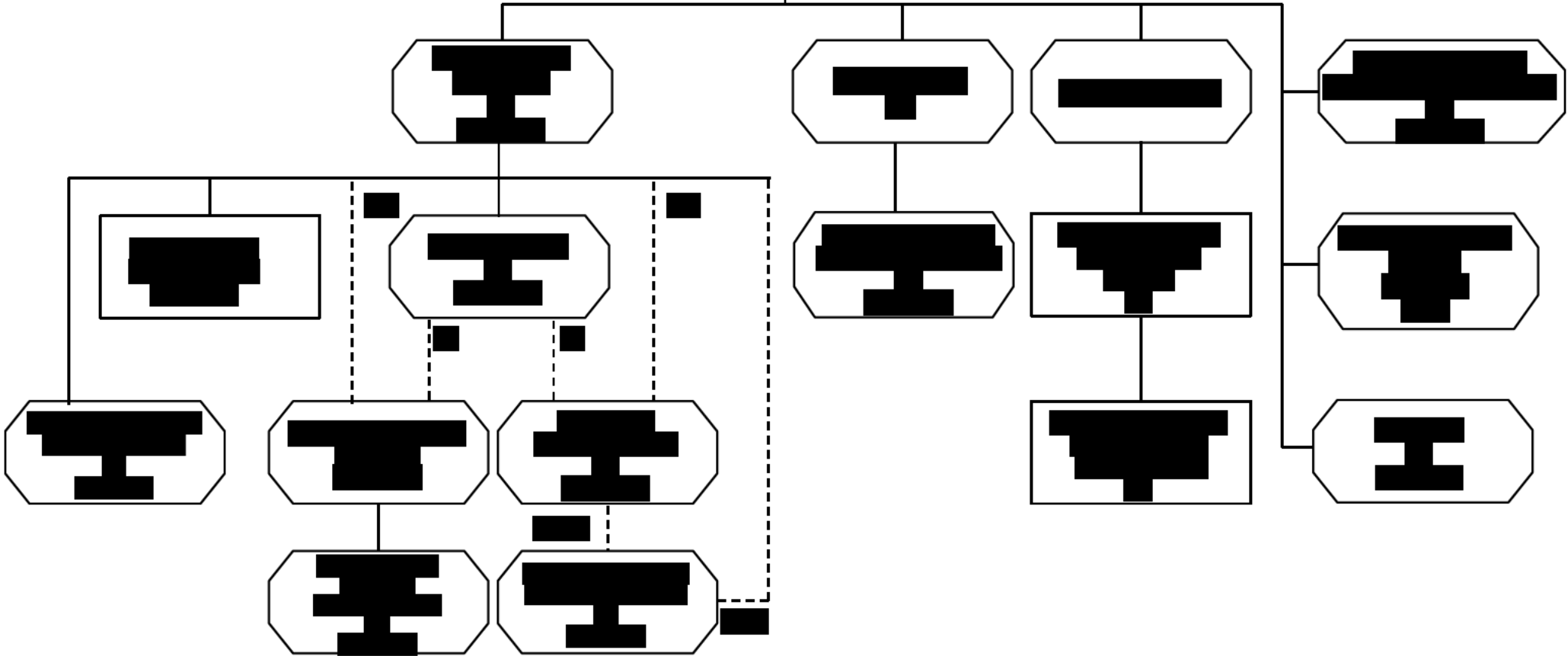
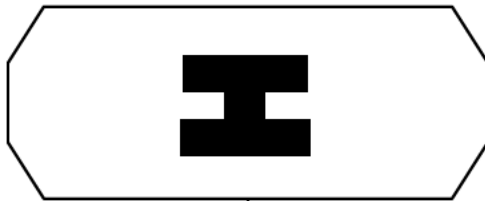


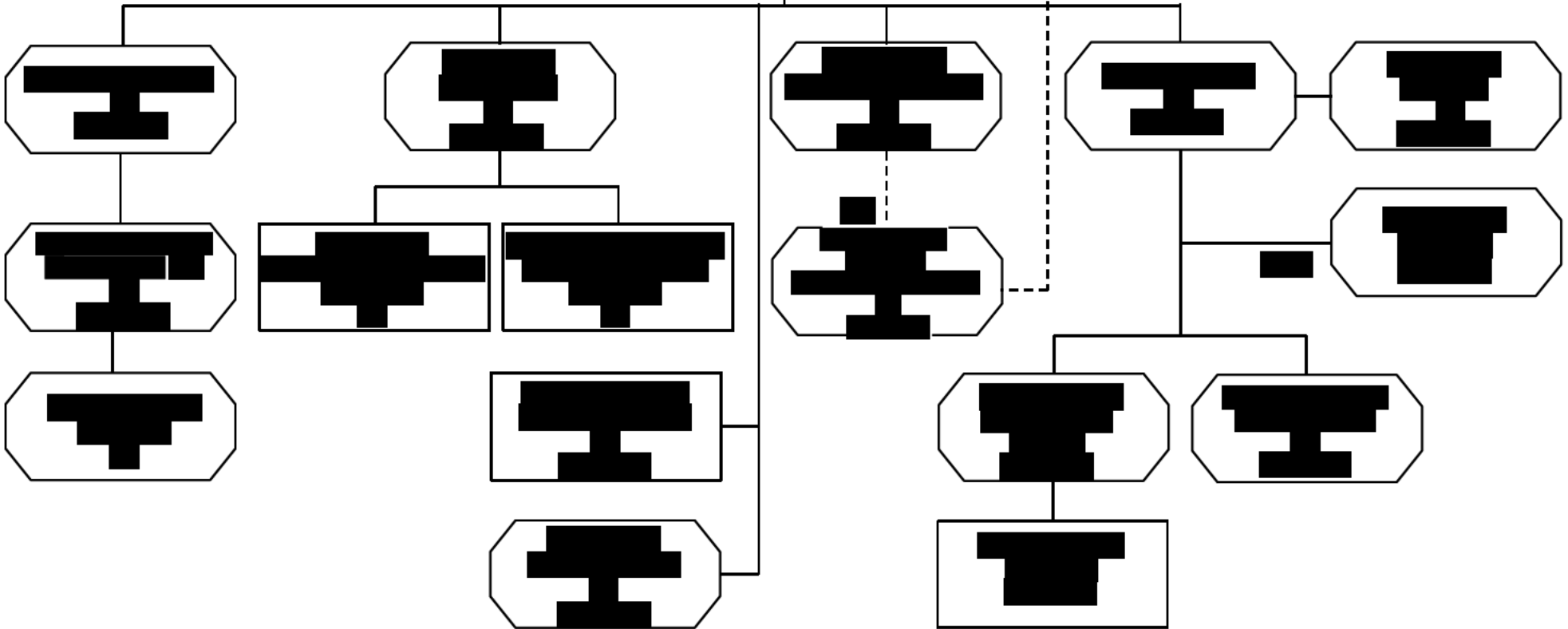
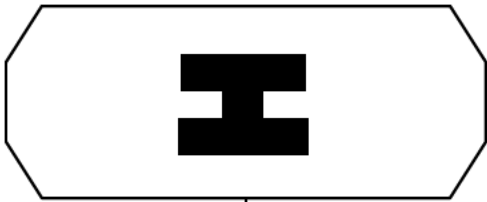


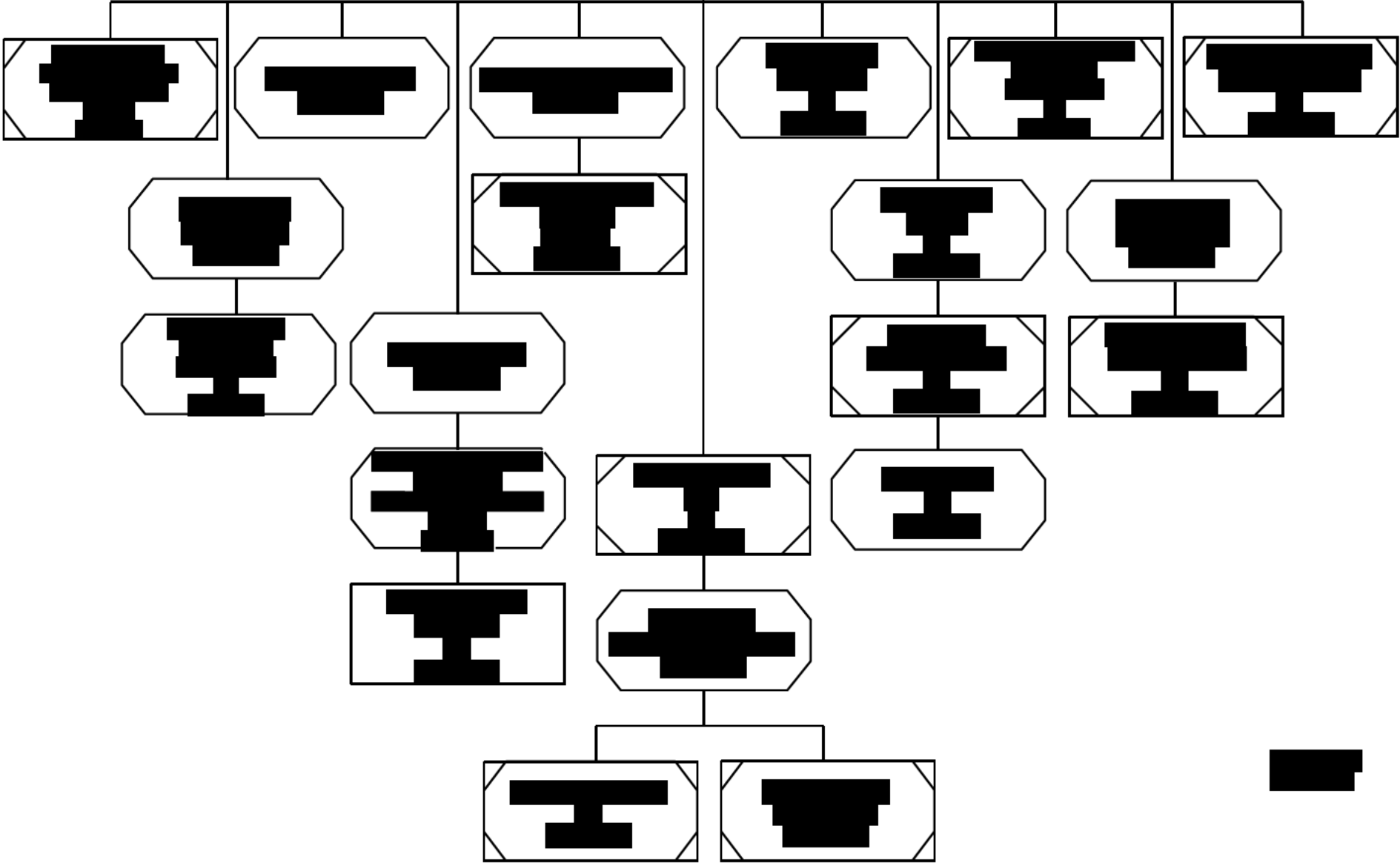
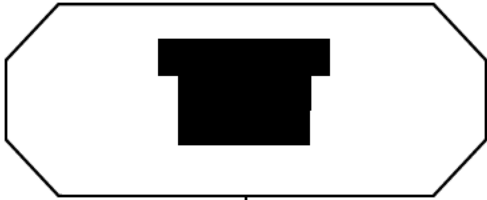


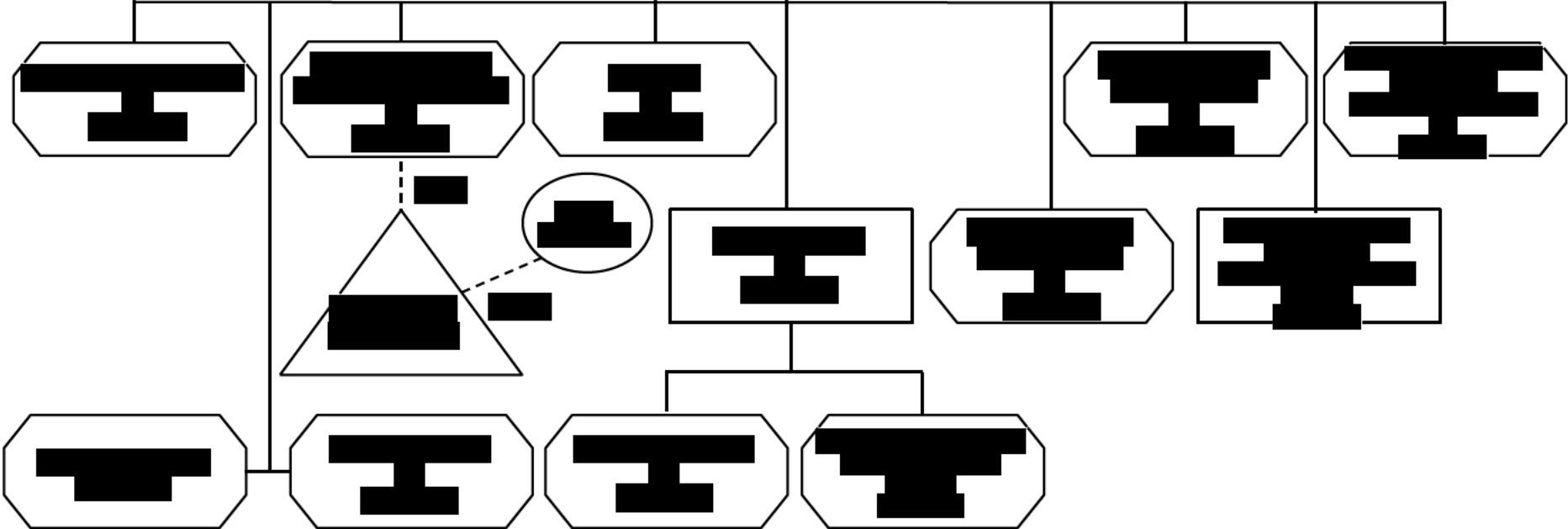
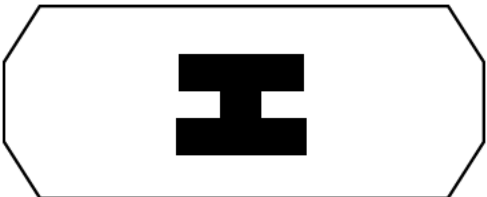


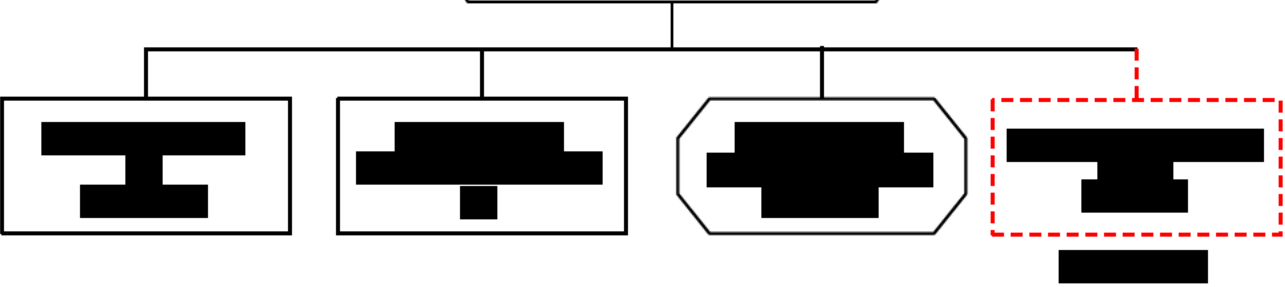
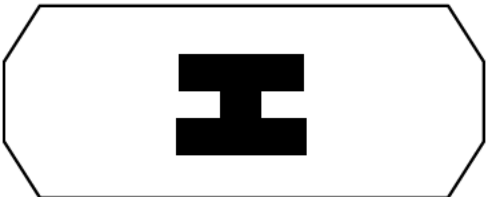




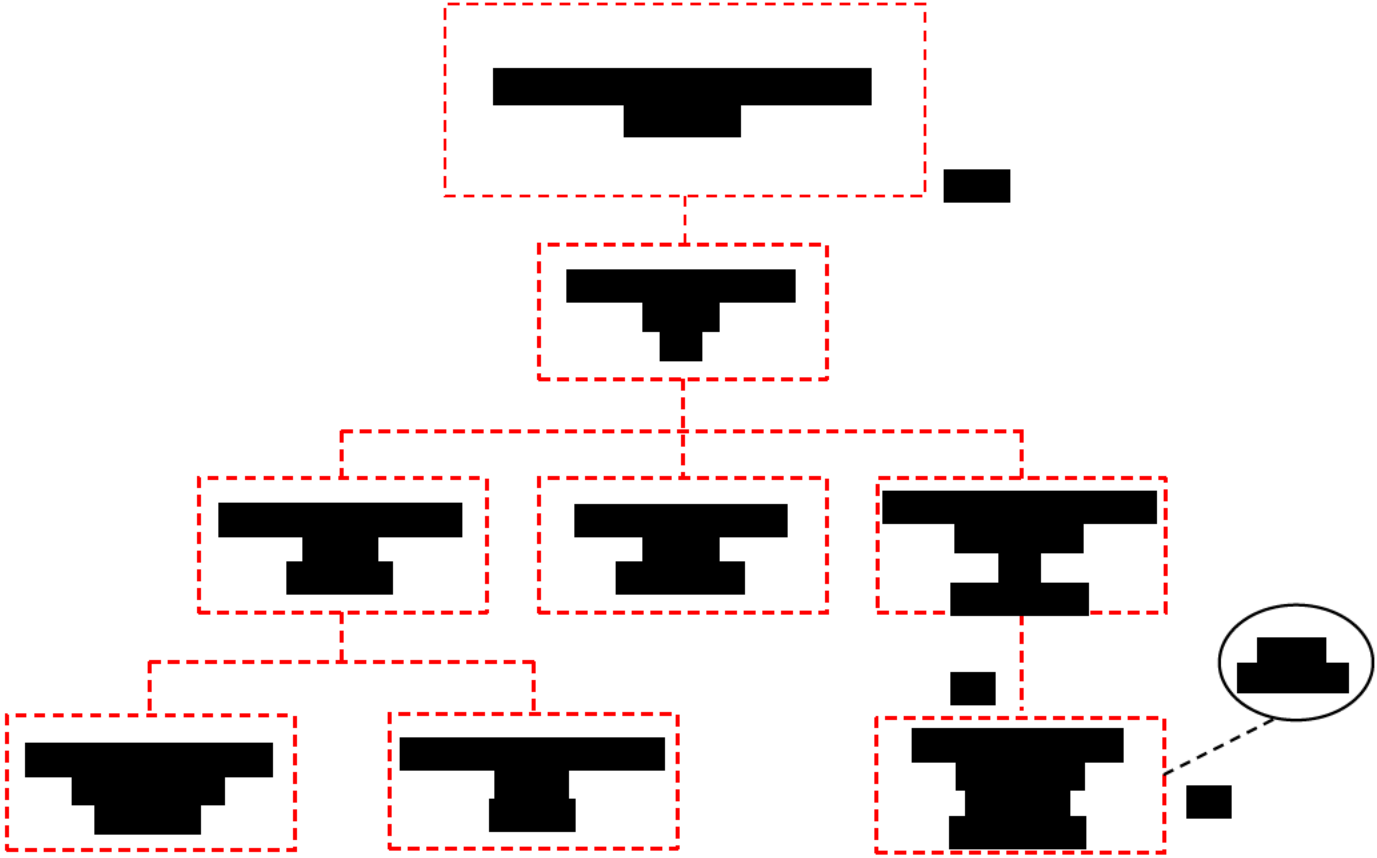








[Redacted]



[Redacted]

[Redacted]

[Redacted]

[Redacted]

[Redacted]

[Redacted]

[Redacted]

[Redacted]

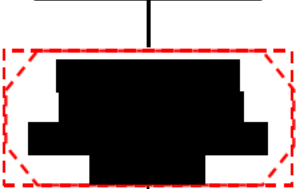
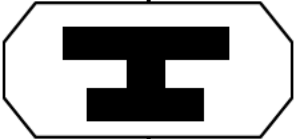
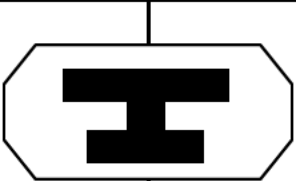
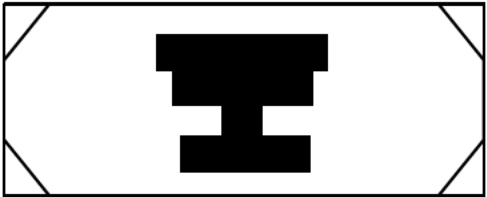
[Redacted]

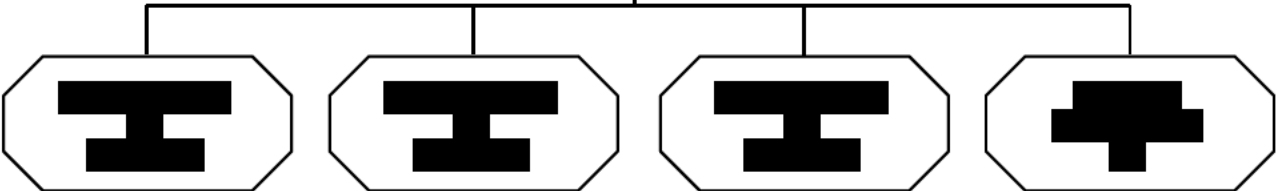
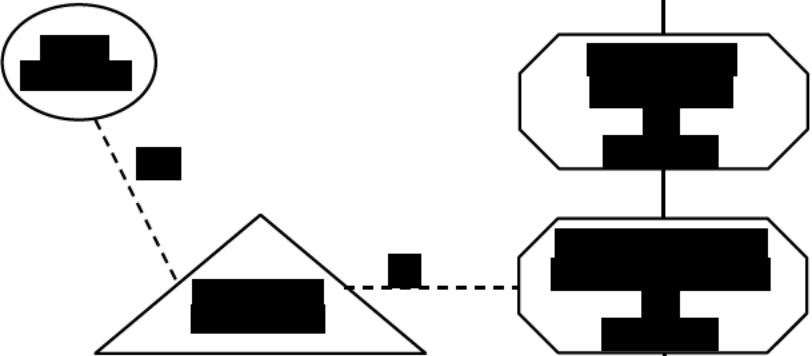
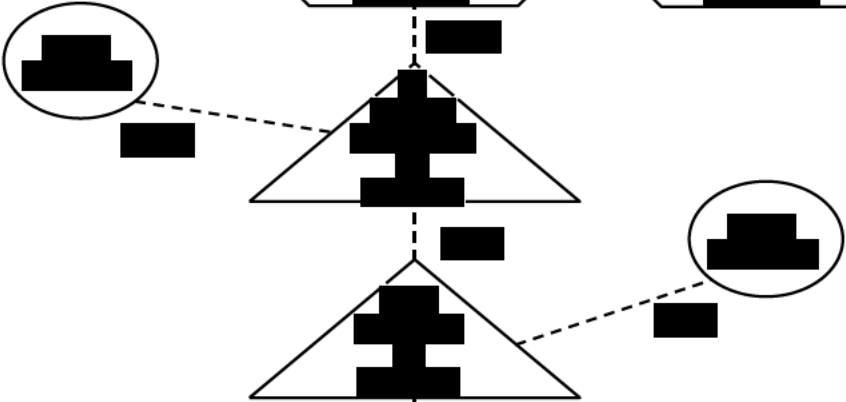
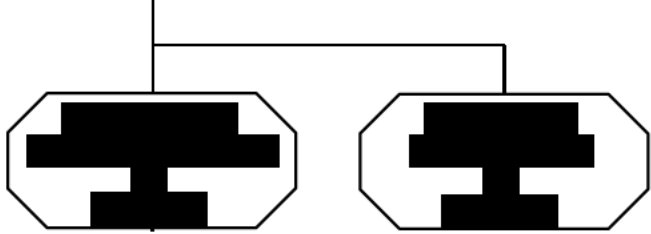
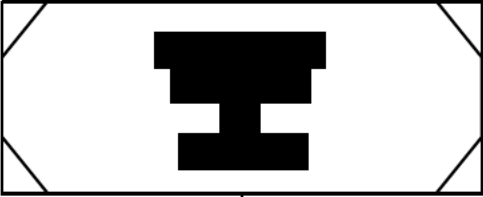
[Redacted]

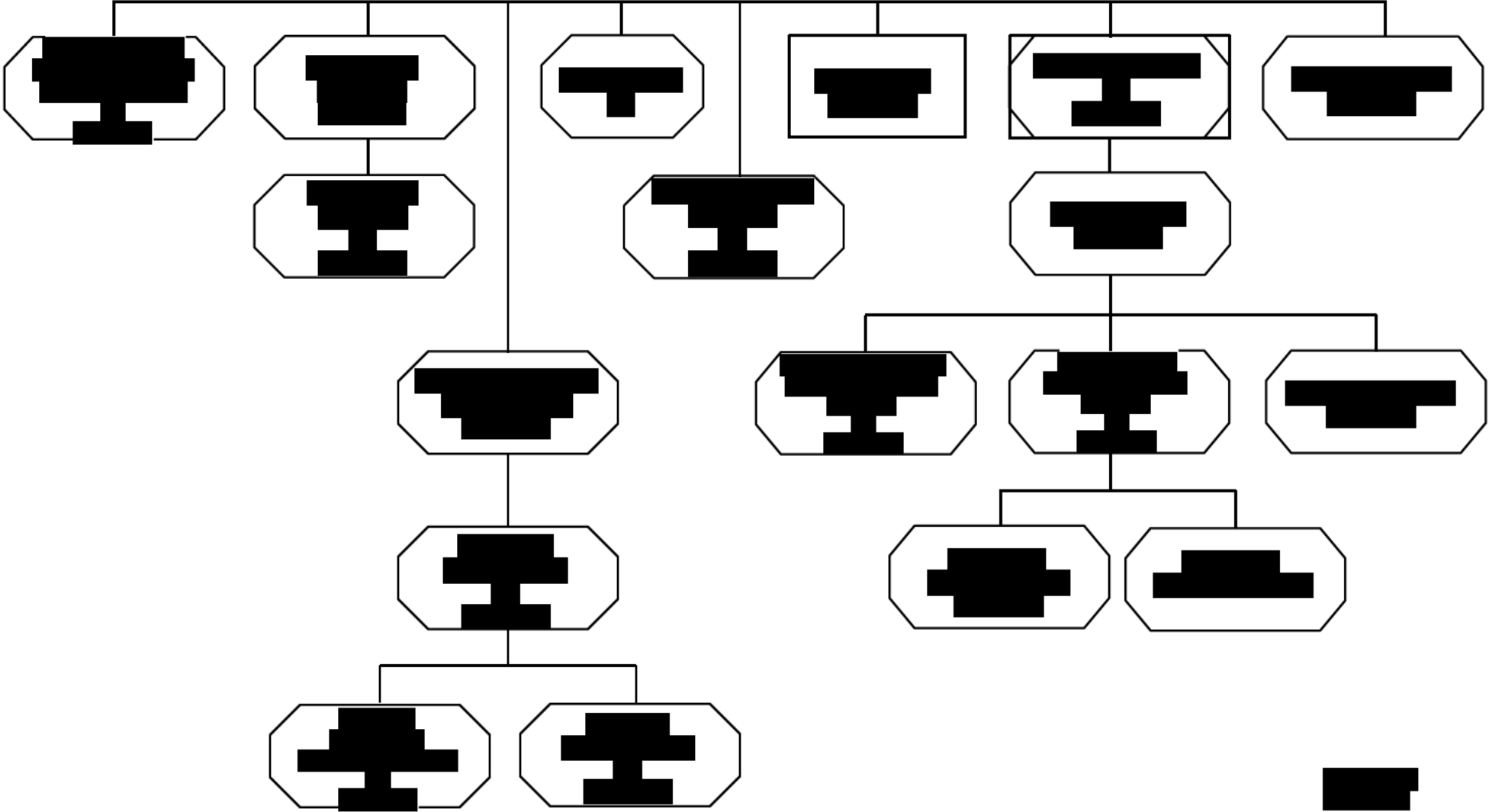
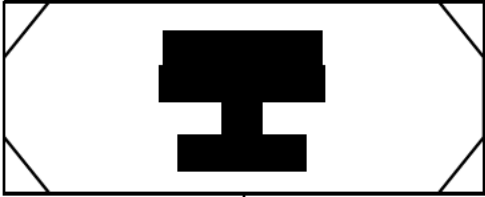
[Redacted]

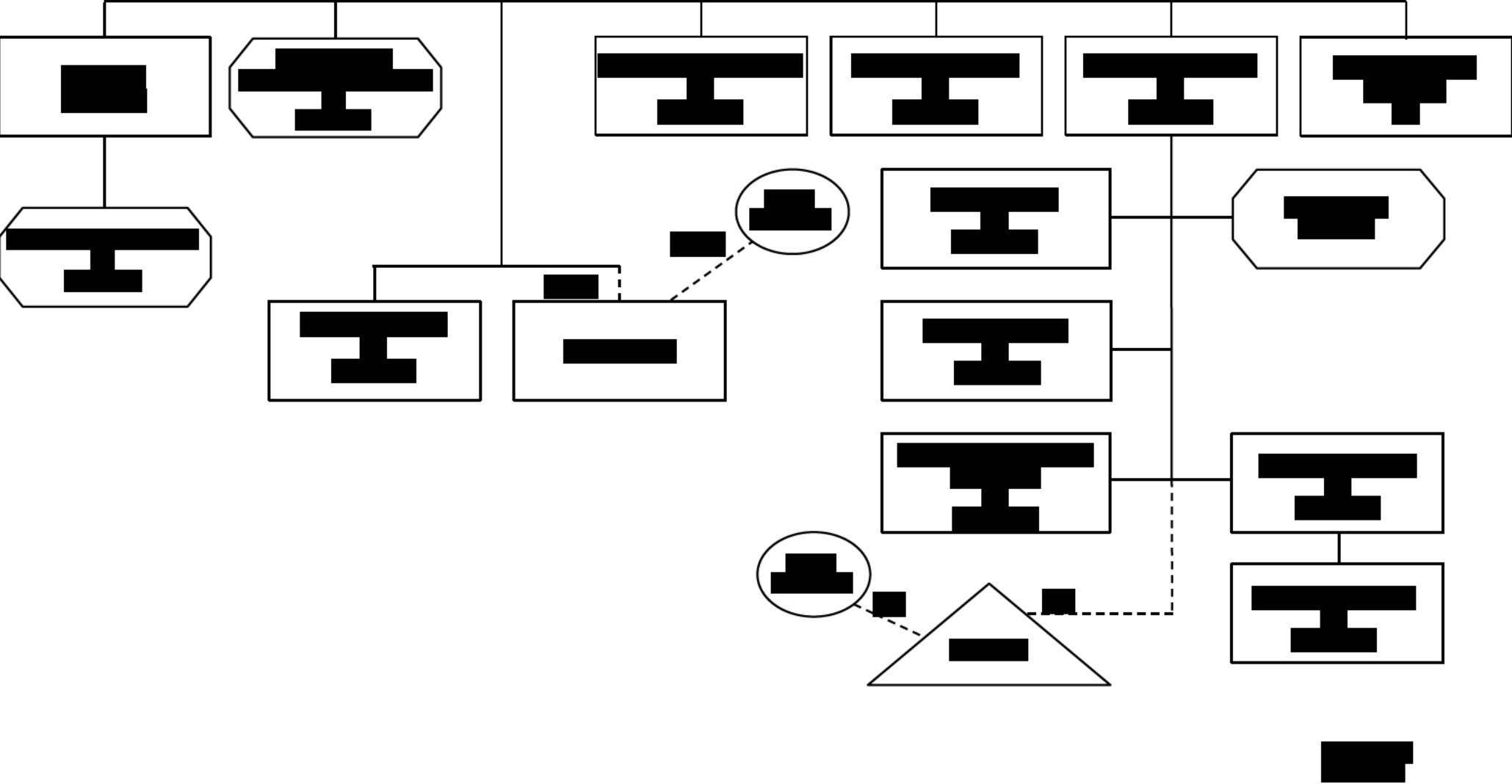
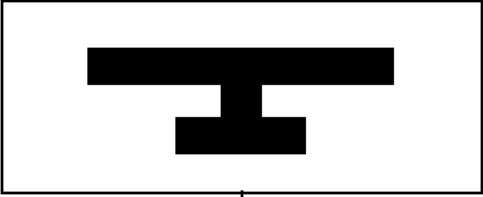
[Redacted]

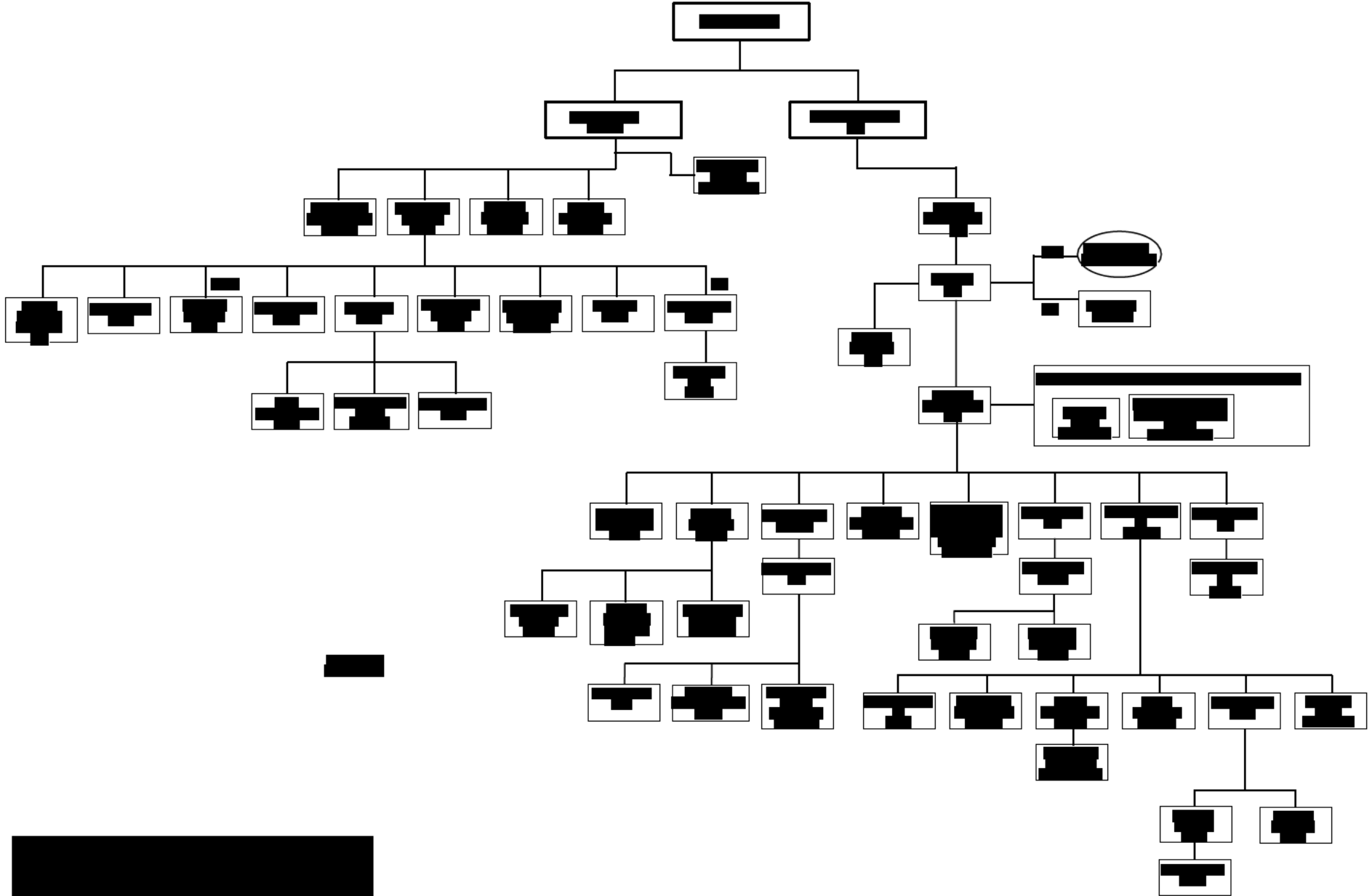












[Redacted]







[REDACTED]

	[REDACTED]	[REDACTED]	[REDACTED]	[REDACTED]
[REDACTED]	[REDACTED]	[REDACTED]	[REDACTED]	[REDACTED]

[REDACTED]

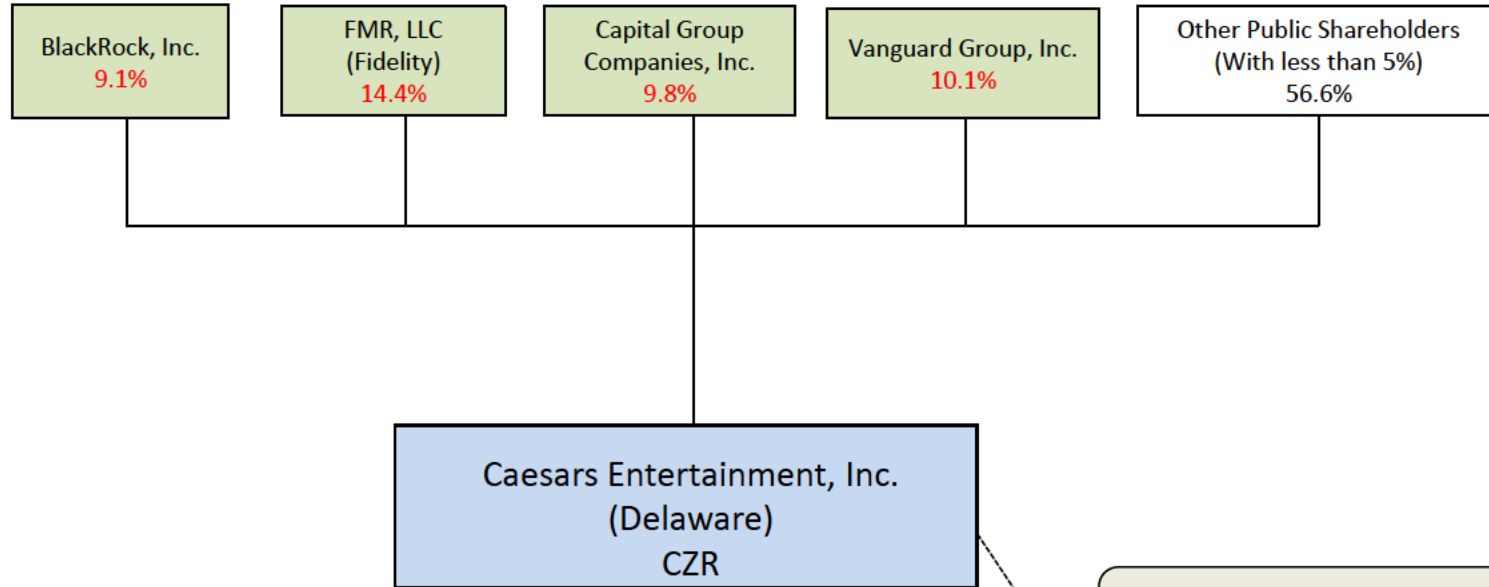


**Exhibit D – 5% or more owners in Caesars  
Entertainment (06.30.2021)**

# Caesars Entertainment, Inc.

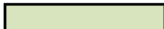

## Public Institutional Investors

As of 06/30/2021\*



**Board of Directors:**

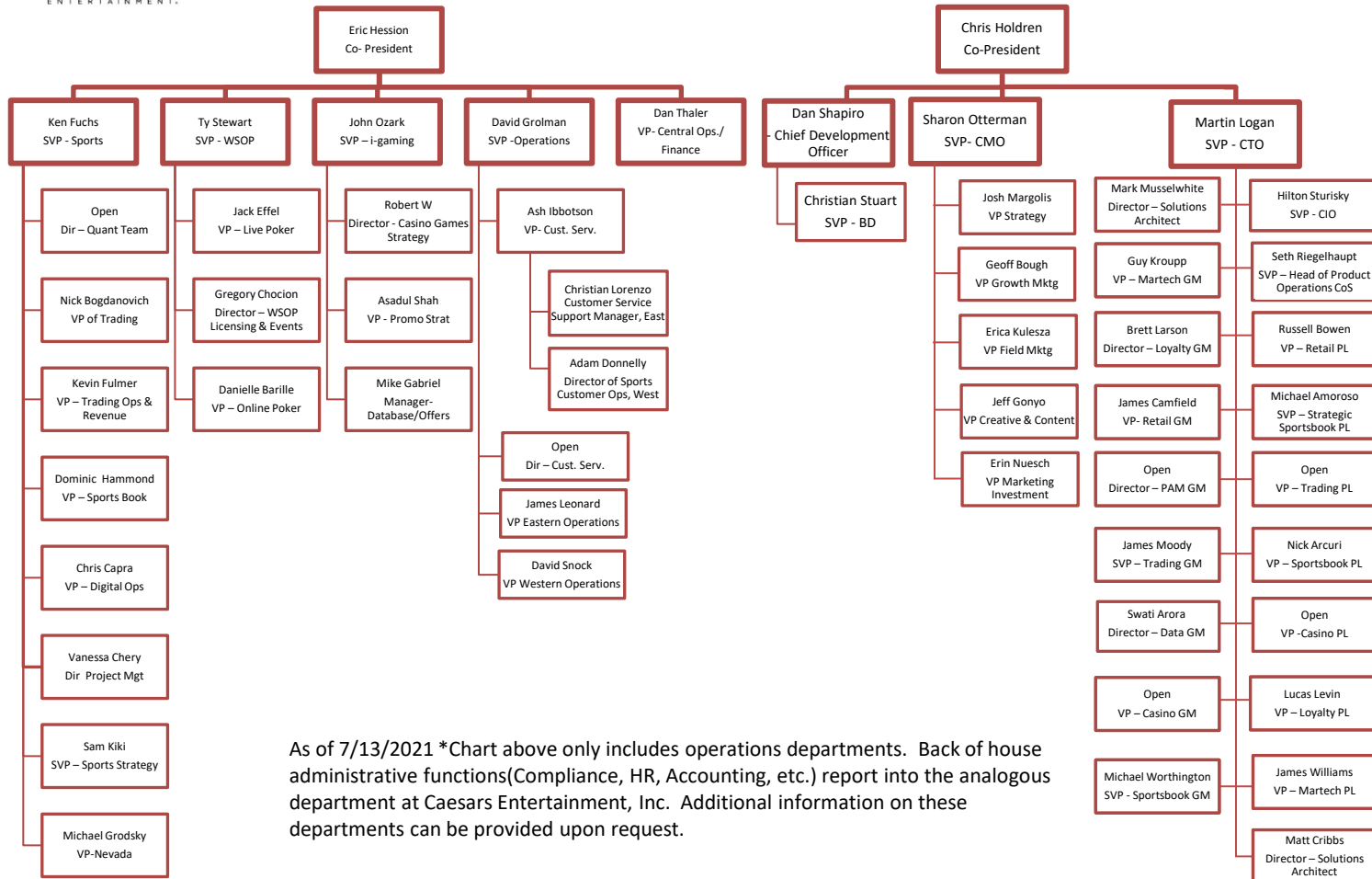
Gary Carano, Executive Chairman	
Don R. Kornstein, Vice Chairman	
Thomas Reeg	Courtney Mather
Bonnie Biumi	Michael Pegram
Janis Jones-Blackhurst	Frank Fahrenkopf
David Tomick	

-  - Institutional Investors > 5% and < 15%
-  - Key Business Entities currently licensed or becoming licensed by various regulatory bodies

\*Note: At the time of this submission, Share reporting is based on the most recent SEC Forms 13D's, 13F's and 13G's filed through May 31, 2021. Total Common Shares Outstanding net of Treasury Stock as of June 30, 2021 was 213,414,176. Values in red reflect estimated common shares only.

# **Exhibit E – Caesars Digital Leadership and Operations Org Chart**

# Caesars Digital



As of 7/13/2021 \*Chart above only includes operations departments. Back of house administrative functions(Compliance, HR, Accounting, etc.) report into the analogous department at Caesars Entertainment, Inc. Additional information on these departments can be provided upon request.

**Exhibit F – American Wagering – Certified  
Copies of NV Articles of Inc. Registration**

STATE OF NEVADA

**BARBARA K. CEGAVSKE**  
Secretary of State



Commercial Recordings Division  
202 N. Carson Street  
Carson City, NV 89701  
Telephone (775) 684-5708  
Fax (775) 684-7138  
  
North Las Vegas City Hall  
2250 Las Vegas Blvd North, Suite 400  
North Las Vegas, NV 89030  
Telephone (702) 486-2880  
Fax (702) 486-2888

**KIMBERLEY PERONDI**  
Deputy Secretary for  
Commercial Recordings

**OFFICE OF THE  
SECRETARY OF STATE**

**Certified Copy**

01/07/2020 10:15:44 AM

**Work Order Number:** W2020010700667 - 333760  
**Reference Number:** 20200402436  
**Through Date:** 01/07/2020 10:15:44 AM  
**Corporate Name:** AMERICAN WAGERING, INC.

The undersigned filing officer hereby certifies that the attached copies are true and exact copies of all requested statements and related subsequent documentation filed with the Secretary of State’s Office, Commercial Recordings Division listed on the attached report.

Document Number	Description	Number of Pages
20120447540-69	Amended and Restated Articles - 06/26/2012	5
20120447460-90	Merge In - 06/26/2012	7
C12630-1995-001	Articles of Incorporation - 08/02/1995	4



Respectfully,

BARBARA K. CEGAVSKE  
Nevada Secretary of State

Certified By: Electronically Certified  
Certificate Number: B20200107493244  
You may verify this certificate  
online at <http://www.nvsos.gov>



ROSS MILLER  
Secretary of State  
204 North Carson Street, Suite 1  
Carson City, Nevada 89701-4520  
(775) 684-5708  
Website: www.nvsos.gov

**Certificate to Accompany  
Restated Articles or  
Amended and Restated Articles**  
(PURSUANT TO NRS)

USE BLACK INK ONLY - DO NOT HIGHLIGHT

ABOVE SPACE IS FOR OFFICE USE ONLY

This Form is to Accompany Restated Articles or Amended and Restated Articles of Incorporation

(Pursuant to NRS 78.403, 82.371, 86.221, 87A, 88.355 or 88A.250)

(This form is also to be used to accompany Restated Articles or Amended and Restated Articles for Limited-Liability Companies, Certificates of Limited Partnership, Limited-Liability Limited Partnerships and Business Trusts)

1 Name of Nevada entity as last recorded in this office:

American Wagering, Inc.

2 The articles are: (mark only one box)  Restated  Amended and Restated

Please entitle your attached articles "Restated" or "Amended and Restated" accordingly

3 Indicate what changes have been made by checking the appropriate box.\*

- No amendments, articles are restated only and are signed by an officer of the corporation who has been authorized to execute the certificate by resolution of the board of directors adopted on  
The certificate correctly sets forth the text of the articles or certificate as amended to the date of the certificate
- The entity name has been amended
- The registered agent has been changed. (attach Certificate of Acceptance from new registered agent)
- The purpose of the entity has been amended
- The authorized shares have been amended
- The directors, managers or general partners have been amended
- IRS tax language has been added.
- Articles have been added
- Articles have been deleted
- Other. The articles or certificate have been amended as follows: (provide article numbers, if available)

The Second Amended and Restated Articles of Incorporation include amendments to update the provisions relating to the constitution of the board of directors and the indemnification of directors and officers.

4 Effective date and time of filing (optional) Date: June 27, 2012 Time: 10:00 a.m., Pacific Time  
(must not be later than 90 days after the certificate is filed)

\* This form is to accompany Restated Articles or Amended and Restated Articles which contain newly altered or amended articles. The Restated Articles must contain all of the requirements as set forth in the statutes for amending or altering the articles for certificates

**IMPORTANT:** Failure to include any of the above information and submit with the proper fees may cause this filing to be rejected

*This form must be accompanied by appropriate fees.*

CERTIFICATE OF  
SECOND AMENDED AND RESTATED ARTICLES OF INCORPORATION  
OF  
AMERICAN WAGERING, INC.

Pursuant to the provisions of Nevada Revised Statutes 78.390 and 78.403, the undersigned officer of American Wagering, Inc., a Nevada corporation, does hereby certify as follows:

A. The Agreement and Plan of Merger, dated as of April 13, 2011, by and among William Hill Holdings Limited, AW Sub Co. and American Wagering, Inc. (the "Merger Agreement") provides for the amendment and restatement of the corporation's articles of incorporation as set forth below.

B. The Merger Agreement, including the amendment and restatement of the corporation's articles of incorporation as set forth below, has been duly approved by the board of directors of the corporation and at least a majority of the voting power of the outstanding shares of voting common stock, which is sufficient for approval thereof.

C. This certificate sets forth the text of the articles of incorporation of the corporation as amended and restated in their entirety to this date as follows:

SECOND AMENDED AND RESTATED ARTICLES OF INCORPORATION  
OF  
AMERICAN WAGERING, INC.

ARTICLE I  
NAME

The name of the corporation is American Wagering, Inc. (the "Corporation").

ARTICLE II  
REGISTERED OFFICE

The Corporation may, from time to time, in the manner provided by law, change the registered agent and registered office within the State of Nevada. The Corporation may also maintain an office or offices for the conduct of its business, either within or without the State of Nevada.

ARTICLE III  
AUTHORIZED CAPITAL STOCK

The total authorized capital stock of the Corporation shall consist of one thousand (1,000) shares of common stock, par value \$0.01 per share.



ARTICLE IV  
DIRECTORS

The members of the governing board of the Corporation are styled as directors. The Board of Directors shall be elected in such manner as shall be provided in the Bylaws of the Corporation. The current Board of Directors consists of two (2) directors. The number of directors may be changed from time to time in such manner as shall be provided in the Bylaws of the Corporation.

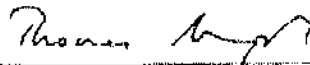
ARTICLE V  
LIMITATIONS ON LIABILITY; INDEMNIFICATION

No director or officer of this Corporation shall be liable to the Corporation or its stockholders for damages for breach of fiduciary duty as a director or officer. This provision shall not eliminate or limit the liability of a director or officer for acts or omissions which involve intentional misconduct, fraud, a knowing violation of law, or the payment of distributions in violation of Nevada Revised Statutes §78.300. If Chapter 78 of the Nevada Revised Statutes is hereafter amended or interpreted to eliminate or limit further the personal liability of directors or officers, then the liability of all directors and officers shall be eliminated or limited to the full extent then so permitted. Neither the amendment nor repeal of this Article FIFTH, nor the adoption of any provision of these Articles of Incorporation inconsistent with the Article FIFTH, shall eliminate or reduce the effect of Article FIFTH in respect of any act or omission that occurred prior to such amendment, repeal, or adoption of an inconsistent provision.

All expenses incurred by officers or directors in defending a civil or criminal action, suit, or proceeding must be paid by the Corporation as they are incurred in advance of a final disposition of the action, suit or proceeding, upon receipt of an undertaking by or on behalf of a director or officer to repay the amount if it is ultimately determined by a court of competent jurisdiction that (i) he or she did not act in good faith, and in the manner he or she reasonably believed to be in or not opposed to the best interests of the Corporation or, with respect to any criminal action or proceeding, (ii) he or she had reasonable cause to believe his or her conduct was unlawful.

\* \* \*

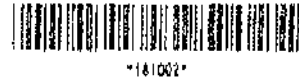
IN WITNESS WHEREOF, I have executed this Certificate of Second Amended and Restated Articles of Incorporation of American Wagering, Inc. as of June 27, 2012.



\_\_\_\_\_  
Name: Thomas Murphy  
Title: Secretary



ROSS MILLER  
Secretary of State  
202 North Carson Street  
Carson City, Nevada 89701-4201  
(775) 684-5708  
Website: www.nvaca.gov



\*181002\*

**Statement of Change of Registered Agent by Represented Entity**  
(PURSUANT TO NRS 77.340)

This form may be submitted by: the Represented Entity to appoint a new Registered Agent or amend own service of process info. For more information please visit <http://www.nvacs.gov/index.aspx?page=141>

USE BLACK INK ONLY - DO NOT HIGHLIGHT

ABOVE SPACE IS FOR OFFICE USE ONLY

1. Name of Represented Entity:  
American Wagering, Inc.

2. Entity File Number: C12630-1995

3. This statement of change will have the following effect: (check only one)

- Appoints a new agent for service of process (complete 4a or 4b)
- Updates contact information of the Represented Entity acting as own agent (complete 4c)

4. Information in effect upon the filing of this statement: (complete only one section)

a) Commercial Registered Agent:  
National Registered Agents, Inc. of Nevada

b) Noncommercial Registered Agent:

Name: \_\_\_\_\_ Nevada \_\_\_\_\_

Street Address: \_\_\_\_\_ City: \_\_\_\_\_ Zip Code: \_\_\_\_\_

Mailing Address (if different from street address): \_\_\_\_\_ City: \_\_\_\_\_ Zip Code: \_\_\_\_\_

c) Title of Office or Other Position within Represented Entity:

Name of Title or Position: \_\_\_\_\_

Street Address: \_\_\_\_\_ City: \_\_\_\_\_ Zip Code: \_\_\_\_\_

Mailing Address (if different from street address): \_\_\_\_\_ City: \_\_\_\_\_ Zip Code: \_\_\_\_\_

5. Signature of Represented Entity. (required)  
X Thomas [Signature] 6-27-12  
Authorized Signature Date

6. Registered Agent Acceptance: (required)  
I hereby accept appointment as Registered Agent for the above named Entity.  
X Sandi [Signature], Assist. Secy. 6-22-12  
Authorized Signature of Registered Agent or On Behalf of Registered Agent Entity Date

FEE: \$60.00

This form must be accompanied by appropriate fees

Nevada Secretary of State Form MA Change by Entity  
Effective 3-13-02



\*140103\*



ROSS MILLER  
Secretary of State  
204 North Carson Street, Suite 1  
Carson City, Nevada 89701-4520  
(775) 684-5708  
Website: www.nvsos.gov

Filed in the Office of	Business Number C12630-1995
	Filing Number 20120447460-90
Secretary of State	Filed On 06/26/2012
State Of Nevada	Number of Pages 7

**Articles of Merger**  
(PURSUANT TO NRS 92A.200)  
**Page 1**

USE BLACK INK ONLY - DO NOT HIGHLIGHT

ABOVE SPACE IS FOR OFFICE USE ONLY

**Articles of Merger**  
(Pursuant to NRS Chapter 92A)

1) Name and jurisdiction of organization of each constituent entity (NRS 92A.200):

If there are more than four merging entities, check box and attach an 8 1/2" x 11" blank sheet containing the required information for each additional entity from article one.

AW Sub Co.

Name of merging entity

Nevada

Jurisdiction

Corporation

Entity type \*

Name of merging entity

Jurisdiction

Entity type \*

Name of merging entity

Jurisdiction

Entity type \*

Name of merging entity

Jurisdiction

Entity type \*

and,

American Wagering, Inc.

Name of surviving entity

Nevada

Jurisdiction

Corporation

Entity type \*

\* Corporation, non-profit corporation, limited partnership, limited-liability company or business trust.

**Filing Fee: \$350.00**

*This form must be accompanied by appropriate fees.*



ROSS MILLER  
Secretary of State  
204 North Carson Street, Suite 1  
Carson City, Nevada 89701-4520  
(775) 684-5708  
Website: www.nvsos.gov

**Articles of Merger**  
(PURSUANT TO NRS 92A.200)  
**Page 2**

USE BLACK INK ONLY - DO NOT HIGHLIGHT

ABOVE SPACE IS FOR OFFICE USE ONLY

2) Forwarding address where copies of process may be sent by the Secretary of State of Nevada (if a foreign entity is the survivor in the merger - NRS 92A.190):

Attn:

c/o:

3) Choose one:

The undersigned declares that a plan of merger has been adopted by each constituent entity (NRS 92A.200).

The undersigned declares that a plan of merger has been adopted by the parent domestic entity (NRS 92A.180).

4) Owner's approval (NRS 92A.200) (options a, b or c must be used, as applicable, for each entity):

If there are more than four merging entities, check box and attach an 8 1/2" x 11" blank sheet containing the required information for each additional entity from the appropriate section of article four.

(a) Owner's approval was not required from

Name of **merging** entity, if applicable

Name of **merging** entity, if applicable

Name of **merging** entity, if applicable

Name of **merging** entity, if applicable

and, or,

Name of **surviving** entity, if applicable

*This form must be accompanied by appropriate fees.*



ROSS MILLER  
Secretary of State  
204 North Carson Street, Suite 1  
Carson City, Nevada 89701-4520  
(775) 684-5708  
Website: www.nvsos.gov

**Articles of Merger**  
(PURSUANT TO NRS 92A.200)  
**Page 3**

USE BLACK INK ONLY - DO NOT HIGHLIGHT

ABOVE SPACE IS FOR OFFICE USE ONLY

(b) The plan was approved by the required consent of the owners of \*:

- AW Sub Co.  
Name of **merging** entity, if applicable
- Name of **merging** entity, if applicable
- Name of **merging** entity, if applicable
- Name of **merging** entity, if applicable

and, or:  
American Wagering, Inc.  
Name of **surviving** entity, if applicable

\* Unless otherwise provided in the certificate of trust or governing instrument of a business trust, a merger must be approved by all the trustees and beneficial owners of each business trust that is a constituent entity in the merger.



ROSS MILLER  
Secretary of State  
204 North Carson Street, Suite 1  
Carson City, Nevada 89701-4520  
(775) 684-5708  
Website: www.nvsos.gov

**Articles of Merger**  
(PURSUANT TO NRS 92A.200)  
**Page 4**

USE BLACK INK ONLY - DO NOT HIGHLIGHT

ABOVE SPACE IS FOR OFFICE USE ONLY

(c) Approval of plan of merger for Nevada non-profit corporation (NRS 92A.160):

The plan of merger has been approved by the directors of the corporation and by each public officer or other person whose approval of the plan of merger is required by the articles of incorporation of the domestic corporation.

Name of **merging** entity, if applicable

Name of **merging** entity, if applicable

Name of **merging** entity, if applicable

Name of **merging** entity, if applicable

and, or;

Name of **surviving** entity, if applicable

*This form must be accompanied by appropriate fees.*



ROSS MILLER  
Secretary of State  
204 North Carson Street, Suite 1  
Carson City, Nevada 89701-4520  
(775) 684-5708  
Website: www.nvsos.gov

**Articles of Merger**  
(PURSUANT TO NRS 92A.200)  
**Page 5**

USE BLACK INK ONLY - DO NOT HIGHLIGHT

ABOVE SPACE IS FOR OFFICE USE ONLY

5) Amendments, if any, to the articles or certificate of the surviving entity. Provide article numbers, if available. (NRS 92A.200)\*:

None.

6) Location of Plan of Merger (check a or b):

(a) The entire plan of merger is attached;

or,

(b) The entire plan of merger is on file at the registered office of the surviving corporation, limited-liability company or business trust, or at the records office address if a limited partnership, or other place of business of the surviving entity (NRS 92A.200).

7) Effective date and time of filing: (optional) (must not be later than 90 days after the certificate is filed)

Date: June 27, 2012

Time: 10:00 a.m., Pacific Time

\* Amended and restated articles may be attached as an exhibit or integrated into the articles of merger. Please entitle them "Restated" or "Amended and Restated," accordingly. The form to accompany restated articles prescribed by the secretary of state must accompany the amended and/or restated articles. Pursuant to NRS 92A.180 (merger of subsidiary into parent - Nevada parent owning 90% or more of subsidiary), the articles of merger may not contain amendments to the constituent documents of the surviving entity except that the name of the surviving entity may be changed.





ROSS MILLER  
Secretary of State  
204 North Carson Street, Suite 1  
Carson City, Nevada 89701-4520  
(775) 684-5708  
Website: www.nvsos.gov

**Articles of Merger**  
(PURSUANT TO NRS 92A.200)  
Page 6

USE BLACK INK ONLY - DO NOT HIGHLIGHT

ABOVE SPACE IS FOR OFFICE USE ONLY

8) Signatures - Must be signed by: An officer of each Nevada corporation; All general partners of each Nevada limited partnership; All general partners of each Nevada limited-liability limited partnership; A manager of each Nevada limited-liability company with managers or one member if there are no managers; A trustee of each Nevada business trust (NRS 92A.230)\*

If there are more than four merging entities, check box and attach an 8 1/2" x 11" blank sheet containing the required information for each additional entity from article eight.

AW Sub Co.

Name of merging entity

X Thomas Miller  
Signature

Secretary  
Title

6/27/2012  
Date

Name of merging entity

X \_\_\_\_\_  
Signature

Title

Date

Name of merging entity

X \_\_\_\_\_  
Signature

Title

Date

Name of merging entity

X \_\_\_\_\_  
Signature

Title

Date

and,

American Wagering, Inc.

Name of surviving entity

X \_\_\_\_\_  
Signature

President and CEO  
Title

Date

\* The articles of merger must be signed by each foreign constituent entity in the manner provided by the law governing it (NRS 92A.230). Additional signature blocks may be added to this page or as an attachment, as needed.

**IMPORTANT:** Failure to include any of the above information and submit with the proper fees may cause this filing to be rejected.

This form must be accompanied by appropriate fees



ROSS MILLER  
Secretary of State  
204 North Carson Street, Suite 1  
Carson City, Nevada 89701-4520  
(775) 684-6708  
Website: www.nvsos.gov

**Articles of Merger**  
(PURSUANT TO NRS 92A.200)  
Page 6

USE BLACK INK ONLY - DO NOT HIGHLIGHT

ABOVE SPACE IS FOR OFFICE USE ONLY

8) Signatures - Must be signed by: An officer of each Nevada corporation; All general partners of each Nevada limited partnership; All general partners of each Nevada limited-liability limited partnership; A manager of each Nevada limited-liability company with managers or one member if there are no managers; A trustee of each Nevada business trust (NRS 92A.230)\*

If there are more than four merging entities, check box and attach an 8 1/2" x 11" blank sheet containing the required information for each additional entity from article eight.

AW Sub Co.  
Name of merging entity

**X**  
\_\_\_\_\_  
Signature Title Date

Name of merging entity  
**X**  
\_\_\_\_\_  
Signature Title Date

Name of merging entity  
**X**  
\_\_\_\_\_  
Signature Title Date

Name of merging entity  
**X**  
\_\_\_\_\_  
Signature Title Date

and,  
American Wagering, Inc.  
Name of surviving entity  
**X** *Julie Salem* President and CEO 06/27/2012  
Signature Title Date

\* The articles of merger must be signed by each foreign constituent entity in the manner provided by the law governing it (NRS 92A.230). Additional signature blocks may be added to this page or as an attachment, as needed.

**IMPORTANT:** Failure to include any of the above information and submit with the proper fees may cause this filing to be rejected.

This form must be accompanied by appropriate fees.

**FILED**  
IN THE OFFICE OF THE  
SECRETARY OF STATE OF THE  
STATE OF NEVADA

AUG 02 1995

17630-95

**ARTICLES OF INCORPORATION**

**OF**

**AMERICAN WAGERING, INC.**

C01743  
AN

**KNOW ALL MEN BY THESE PRESENTS:**

That we, the undersigned, for the purpose of association to establish a corporation for the transaction of business and the promotion and conduct of the objects and purposes hereinafter stated, under the provisions of and subject to the requirements of the laws of the State of Nevada, do make, record and file these Articles of Incorporation in writing.

**AND WE DO HEREBY CERTIFY:**

**FIRST:** The name of the Corporation is:

**AMERICAN WAGERING, INC.**

**SECOND:** The Resident Agent shall be Gordon, Silver & Beesley, Ltd. The address of the registered office in the State of Nevada where process may be served upon the Corporation is 3800 Howard Hughes Parkway, Fourteenth Floor, Las Vegas, Nevada. The Corporation may also maintain an office or offices at such other places within or outside the State of Nevada, as it may from time to time determine. Corporate business of every kind and nature may be conducted, and meetings of directors and stockholders held outside the State of Nevada, the same as in the State of Nevada.

**THIRD:** The Corporation may engage in any lawful activity but in no event shall the Corporation engage in any gaming activity in the State of Nevada until such time, if any, as the Corporation shall be licensed or found suitable by the Nevada Gaming Commission.

**FOURTH:** This Corporation is authorized to issue only one class of shares of stock, the total number of which is 25,000,000 shares, with \$0.01 par value. Such stock may be issued by the Corporation from time to time by the Board of Directors thereof. The shares of stock shall be designated "Common Stock" and the holders thereof shall be entitled to one (1) vote for each share held by them.

**FIFTH:** No Director or Officer of this Corporation shall be liable to the corporation or its stockholders for any breach of fiduciary duty as Officer or Director of the Corporation. This provision shall not affect liability for acts or omissions which involve intentional misconduct, fraud, a knowing violation of law, or the payment of dividends in violation of Nevada Revised Statutes ("NRS") § 78.300.

All expenses incurred by Officers or Directors in defending a civil or criminal action, suit, or proceeding, must be paid by the Corporation as they are incurred in advance of a final disposition of the action, suit or proceeding, upon receipt of an undertaking by or on behalf of a Director or Officer to repay the amount if it is ultimately determined by a court of competent jurisdiction, that he or she did not act in good faith, and in the manner he or she reasonably believed to be or not opposed to the best interests of the Corporation.

SIXTH: The members of the governing board shall be styled Directors, and the number of Directors shall not be less than one (1) pursuant to the terms of NRS § 78.115. The names and post office addresses of the first Board of Directors, which shall consist of six (6) members is as follows:

NAME	ADDRESS
VICTOR SALERNO	675 Grier Las Vegas, Nevada 89119
MICHAEL ROXBOROUGH	675 Grier Las Vegas, Nevada 89119
MICHAEL MERRILAT	675 Grier Las Vegas, Nevada 89119
ROBERT BARENGO	675 Grier Las Vegas, Nevada 89119
ROBERT CIUNCI	675 Grier Las Vegas, Nevada 89119
JAMES VACCARO	675 Grier Las Vegas, Nevada 89119

The number of Directors of this Corporation may from time to time be increased or decreased as set forth hereinabove by an amendment to the By-laws in that regard, and without the necessity of amending these Articles of Incorporation.

The name and address of the Incorporator is as follows:

NAME	ADDRESS
JAMES S. MACE	3800 Howard Hughes Parkway 14th Floor Las Vegas, Nevada 89109


SEVENTH: The capital stock of this Corporation after the amount of the subscription price has been paid in cash or in kind, shall be and remain non-assessable and shall not be subject to assessment to pay debts of the Corporation.

EIGHTH: This Corporation shall have perpetual existence.

NINTH: No holder of any shares of the Corporation shall have any preemptive right to purchase, subscribe for, or otherwise acquire any shares of the Corporation of any class now or hereafter authorized, or any securities exchangeable for or convertible into such shares, or warrants or other instruments evidencing rights or options to subscribe for, purchase or otherwise acquire such shares.

TENTH: This Corporation shall not be governed by the provisions of NRS §§ 78.378 to 78.3793 inclusive, or NRS §§ 78.411 to 78.444, inclusive.

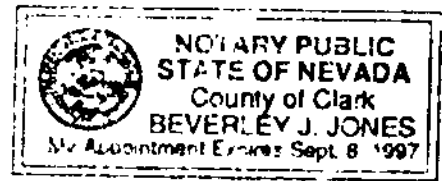
EXECUTED this 15<sup>th</sup> day of August, 1995.

  
\_\_\_\_\_  
JAMES S. MACE

STATE OF NEVADA        )  
                                  )     ss.  
COUNTY OF CLARK     )

This instrument was acknowledged before me on August ~~15<sup>th</sup>~~ 1995 by James S. Mace

  
\_\_\_\_\_  
Notary Public



RECEIVED

AUG 02 1995

Secretary of State  
August 1, 1995  
11:55am

**FILED**  
IN THE OFFICE OF THE  
SECRETARY OF STATE OF THE  
**STATE OF NEVADA** CERTIFICATE OF ACCEPTANCE

AUG 02 1995 OF APPOINTMENT OF RESIDENT AGENT

12630-05

In the matter of AMERICAN WAGERING, INC., I hereby certify that on the 15<sup>th</sup> day of August, 1995, I accepted the appointment as Resident Agent of the above-entitled corporation in accordance with Nevada Revised Statutes § 78.090.

IN WITNESS WHEREOF, I have hereunto set my hand this 15<sup>th</sup> day of August, 1995.

GORDON, SILVER & BEESLEY, LTD.

By: \_\_\_\_\_

James S. Mace

RECEIVED

AUG 02 1995

Secretary of State

# SECRETARY OF STATE

## STATE OF NEVADA

<b>APOSTILLE</b> (Convention de La Haye du 5 October 1961)			
<b>1. Country:</b> Pays/Pals:	UNITED STATES OF AMERICA		
<b>This public document</b> Le present acte public / El present documento publico			
<b>2. has been signed by:</b> a ete signe par ha sido firmado po	BARBARA K. CEGAVSKE		
<b>3. acting in the capacity of</b> agissant an qualite de quien actua en calidad de	SECRETARY OF STATE		
<b>4. bears the seal/stamp of</b> est revetu du sceau / timbre de y esta revestido del sello / timbre de	THE STATE OF NEVADA		
<b>CERTIFIED</b> Atteste / Certificado			
<b>5. at</b> a / en	Carson City, Nevada, U.S.A		
<b>6. the</b> le / el dia	SEVENTH DAY OF JANUARY, 2020		
<b>7. by</b> par / por	Barbara K. Cegavske, Secretary of State, State of Nevada, U.S.A		
<b>8. Number</b> sous no bajo el numero	B20200107493244		
<b>9 Seal/Stamp:</b> Sceau / timbre: Sello / timbre:		<b>10. Signature:</b> Signature: Firma:	  BARBARA K. CEGAVSKE Nevada Secretary of State

This Apostille only certifies the authenticity of the signature and the capacity of the person who has signed the public document, and, where appropriate, the identity of the seal or stamp which the public document bears.

This Apostille does not certify the content of the document for which it was issued.

This Apostille is not valid for use anywhere within United States of America, its territories or possessions.

Cette Apostille atteste uniquement la véracité de la signature, la qualité en laquelle le signature de l'acte a agi et, le cas échéant, l'identité du sceau ou timbre dont cet acte public est revêtu.

Cette Apostille ne certifie pas le contenu de l'acte pour lequel elle a été émise.

L'utilisation de cette Apostille n'est pas valable en/au Etats-Unis d'Amérique, ses territoires ou possessions.

Esta Apostilla certifica unicamente la autenticidad de la firma, la calidad en que el signatario del documento haya actuado y, en su caso, la identidad del sello o timbre del que el documento publico esté revestido.

Esta Apostilla no certifica el contenido del documento para el cual se expidió.

No es valido el uso de esta Apostilla en los Estados Unidos de America, sus territorios o posesiones.

**Exhibit G – William Hill US Holdco - Certified  
copies of Articles of Incorporation**



# Delaware

PAGE 1

## The First State

I, JEFFREY W. BULLOCK, SECRETARY OF STATE OF THE STATE OF DELAWARE, DO HEREBY CERTIFY THE ATTACHED IS A TRUE AND CORRECT COPY OF THE CERTIFICATE OF INCORPORATION OF "WILLIAM HILL U.S. HOLDCO, INC.", FILED IN THIS OFFICE ON THE EIGHTH DAY OF APRIL, A.D. 2011, AT 2:49 O'CLOCK P.M.

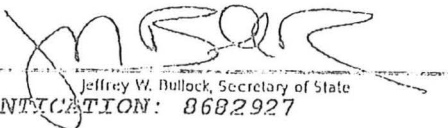
A FILED COPY OF THIS CERTIFICATE HAS BEEN FORWARDED TO THE KENT COUNTY RECORDER OF DEEDS.

4966401 8100

110396394

You may verify this certificate online  
at [corp.delaware.gov/authver.shtml](http://corp.delaware.gov/authver.shtml)



  
Jeffrey W. Bullock, Secretary of State  
AUTHENTICATION: 8682927

DATE: 04-11-11

State of Delaware  
Secretary of State  
Division of Corporations  
Delivered 03:19 PM 04/08/2011  
FILED 02:49 PM 04/08/2011  
SRV 110396394 - 4966401 FILE

**CERTIFICATE OF INCORPORATION  
OF  
WILLIAM HILL U.S. HOLDCO, INC.**

**ARTICLE I  
NAME OF CORPORATION**

The name of the Corporation (the "Corporation") is:

William Hill U.S. HoldCo, Inc.

**ARTICLE II  
REGISTERED OFFICE**

The address of the registered office of the Corporation in the State of Delaware is 160 Greentree Drive, Suite 101, in the City of Dover 19904, County of Kent, and the name of its registered agent at that address is National Registered Agents, Inc.

**ARTICLE III  
PURPOSE**

The purpose of the Corporation is to engage in any lawful act or activity for which Corporations may be organized under the General Corporation Law of the State of Delaware.

**ARTICLE IV  
AUTHORIZED CAPITAL STOCK**

The Corporation shall be authorized to issue one class of stock to be designated Common Stock; the total number of shares which the Corporation shall have authority to issue is 1,000, and each such share shall have a par value of \$0.01.

**ARTICLE V  
BOARD POWER REGARDING BYLAWS**

In furtherance and not in limitation of the powers conferred by statute, the Board of Directors is expressly authorized to make, repeal, alter, amend and rescind the bylaws of the Corporation.

---

**ARTICLE VI  
ELECTION OF DIRECTORS**

Elections of directors need not be by written ballot unless the bylaws of the Corporation shall so provide.

**ARTICLE VII  
LIABILITY**

A director of the Corporation shall not be liable to the corporation or its stockholders for monetary damages for breach of fiduciary duty as a director, except to the extent such exemption from liability or limitation thereof is not permitted under the General Corporation Law of the State of Delaware as the same exists or may hereafter be amended. Any amendment, modification or repeal of the foregoing sentence shall not adversely affect any right or protection of a director of the corporation hereunder in respect of any act or omission occurring prior to the time of such amendment, modification or repeal.

**ARTICLE VIII  
CORPORATE POWER**

The Corporation reserves the right to amend, alter, change or repeal any provision contained in this Certificate of Incorporation, in the manner now or hereafter prescribed by statute, and all rights conferred on stockholders herein are granted subject to this reservation.

**ARTICLE IX  
INCORPORATOR**

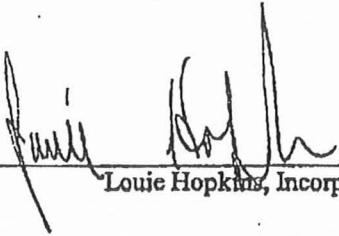
The name and mailing address of the incorporator of the Corporation is:

Louie Hopkins  
Gibson, Dunn & Crutcher LLP  
333 S. Grand Avenue, 46<sup>th</sup> Floor  
Los Angeles, CA 90071

---

THE UNDERSIGNED, being the incorporator hereinbefore named, for the purpose of incorporating and organizing a corporation under the General Corporation Law of the State of Delaware, does make and file this Certificate of Incorporation.

Dated: April 8, 2011

  
\_\_\_\_\_  
Louie Hopkins, Incorporator

# **Exhibit H – Caesars Entertainment Certificate of Incorporation**

# Delaware

The First State

Page 1

*I, JEFFREY W. BULLOCK, SECRETARY OF STATE OF THE STATE OF DELAWARE DO HEREBY CERTIFY THAT THE ATTACHED IS A TRUE AND CORRECT COPY OF THE CERTIFICATE OF INCORPORATION OF "CAESARS ENTERTAINMENT, INC." FILED IN THIS OFFICE ON THE TWENTIETH DAY OF JULY, A.D. 2020, AT 11:17 O`CLOCK A.M.*



  
Jeffrey W. Bullock, Secretary of State

3272809 8100F  
SR# 20206302584

Authentication: 203310093  
Date: 07-20-20

You may verify this certificate online at [corp.delaware.gov/authver.shtml](http://corp.delaware.gov/authver.shtml)

# Delaware

The First State

Page 1

I, JEFFREY W. BULLOCK, SECRETARY OF STATE OF THE STATE OF DELAWARE, DO HEREBY CERTIFY THE ATTACHED IS A TRUE AND CORRECT COPY OF THE CERTIFICATE OF CONVERSION OF A NEVADA CORPORATION UNDER THE NAME OF "ELDORADO RESORTS, INC." TO A DELAWARE CORPORATION, CHANGING ITS NAME FROM "ELDORADO RESORTS, INC." TO "CAESARS ENTERTAINMENT, INC.", FILED IN THIS OFFICE ON THE TWENTIETH DAY OF JULY, A.D. 2020, AT 11:17 O`CLOCK A.M.



  
Jeffrey W. Bullock, Secretary of State

3272809 8100F  
SR# 20206302584

Authentication: 203310093  
Date: 07-20-20

You may verify this certificate online at [corp.delaware.gov/authver.shtml](http://corp.delaware.gov/authver.shtml)

State of Delaware  
Secretary of State  
Division of Corporations  
Delivered 11:17 AM 07/20/2020  
FILED 11:17 AM 07/20/2020  
SR 20206302584 - File Number 3272809

STATE OF DELAWARE  
CERTIFICATE OF CONVERSION  
FROM A NON-DELAWARE CORPORATION  
TO A DELAWARE CORPORATION  
PURSUANT TO SECTION 265 OF THE  
DELAWARE GENERAL CORPORATION LAW

- 1.) The jurisdiction where the Non-Delaware Corporation first formed is Nevada.
- 2.) The jurisdiction immediately prior to filing this Certificate is Nevada.
- 3.) The date the Non-Delaware Corporation first formed is September 6, 2013.
- 4.) The name of the Non-Delaware Corporation immediately prior to filing this Certificate is Eldorado Resorts, Inc..
- 5.) The name of the Corporation as set forth in the Certificate of Incorporation is Caesars Entertainment, Inc..

IN WITNESS WHEREOF, the undersigned being duly authorized to sign on behalf of the converting Non-Delaware Corporation have executed this Certificate on the 20 day of July, A.D. 2020.

DocuSigned by:  
By: Edmund L. Quatmann, Jr.  
E9DBB5C94EF143B...

Name: Edmund L. Quatmann, Jr.  
Print or Type

Title: Secretary  
Print or Type



**CERTIFICATE OF INCORPORATION  
OF  
CAESARS ENTERTAINMENT, INC.**

**ARTICLE I  
CORPORATE NAME**

The name of the corporation (the "Corporation") is Caesars Entertainment, Inc.

**ARTICLE II  
REGISTERED OFFICE**

The address of the registered office of the Corporation in the State of Delaware is 1209 Orange Street, in the City of Wilmington, postal code 19801, in the County of New Castle. The name of the registered agent of the Corporation at that address is The Corporation Trust Company.

**ARTICLE III  
CORPORATE PURPOSE**

The purpose of the Corporation is to engage in any lawful act or activity for which a corporation may be organized under the Delaware General Corporation Law ("DGCL").

**ARTICLE IV  
CAPITALIZATION**

The Corporation is authorized to issue three hundred million (300,000,000) shares of common stock having a par value of \$0.00001 per share (hereinafter referred to as "Common Stock"). Each outstanding share of Common Stock shall entitle the holder thereof to one vote on each matter properly submitted to the stockholders of the Corporation for their vote.

**ARTICLE V  
BOARD OF DIRECTORS**

A. Management.

The business and affairs of the Corporation shall be managed by or under the direction of the Board of Directors. In addition to the powers and authority expressly conferred upon them by statute or by this Certificate of Incorporation or the Bylaws of the Corporation, the directors are hereby empowered to exercise all such powers and do all such acts and things as may be exercised or done by the Corporation. An annual meeting of stockholders, for the election of directors and for the transaction of such other business as may properly come before the meeting, shall be held at such place, on such date, and at such time as Board of Directors shall fix.

B. Number of Directors.

The number of directors shall be fixed from time to time exclusively by the Board of Directors pursuant to a resolution adopted the Board of Directors, subject to the limitations set

forth in the Bylaws of the Corporation, with each director to hold office until his or her successor shall have been duly elected and qualified.

C. Election of Directors; Vacancies.

At each annual meeting of stockholders, (i) directors shall be elected, with each director to hold office until his or her successor shall have been duly elected and qualified; and (ii) if authorized by a resolution of the Board of Directors, directors may be elected to fill any vacancy on the Board of Directors, regardless of how such vacancy shall have been created. Advance notice of stockholder nominations for the election of directors and of business to be brought by stockholders before any meeting of the stockholders of the Corporation shall be given in the manner provided in the Bylaws of the Corporation. The directors of the Corporation need not be elected by written ballot unless the Bylaws so provide. There shall be no right with respect to shares of stock of the Corporation to cumulate votes in the election of directors.

Newly created directorships resulting from any increase in the authorized number of directors or any vacancies in the Board of Directors resulting from death, resignation, disqualification, removal from office or other cause shall, unless otherwise required by law, be filled only by (i) the holders of a majority of the voting power of all then outstanding capital stock of the Corporation then entitled to vote generally in the election of directors at a meeting of stockholders called for such purpose or (ii) the unanimous written consent or vote of a majority of the directors then in office, though less than a quorum, and directors so chosen shall serve for a term expiring at the next annual meeting of stockholders, with each director to hold office until his or her successor shall have been duly elected and qualified. .

D. Term of Members of Board of Directors.

Each member of the Board of Directors shall serve for one (1) year or until his or her successor shall be elected and qualified, or his or her earlier removal or resignation. No decrease in the number of directors constituting the Board of Directors shall shorten the term of any incumbent director.

E. Quorum.

A majority of the Whole Board shall constitute a quorum for all purposes at any meeting of the Board of Directors, and, except as otherwise expressly required by law or by this Certificate of Incorporation, all matters shall be determined by the affirmative vote of a majority of the directors present at any meeting at which a quorum is present.

F. Removal of Directors.

Any director, or the entire Board of Directors, may be removed from office at any time, with or without cause, by the affirmative vote of the holders of a majority of the voting power of all of the then-outstanding shares of capital stock of the Corporation then entitled to vote at an election of directors.

G. Special Meetings.

Special meetings of the stockholders, other than those required by statute, may be called at any time by the President or Board of Directors acting pursuant to a resolution adopted by a majority of the Whole Board and shall be called by the President at the request in writing of stockholders owning not less than 10% of the entire capital stock of the Corporation issued and outstanding and entitled to vote. Any special meeting called at the request of the stockholders pursuant to the preceding sentence shall be held on a date no later than 60 days following the Corporation's receipt of the stockholders' written request for such a meeting. The Board of Directors may postpone or reschedule any previously scheduled special meeting, other than a special meeting called at the request of the stockholders in accordance with this Section G.

## **ARTICLE VI DIRECTOR AND OFFICER LIABILITY**

A director of the Corporation shall not be personally liable to the Corporation or its stockholders for monetary damages for breach of fiduciary duty as a director, except for liability (i) for any breach of the director's duty of loyalty to the Corporation or its stockholders, (ii) for acts or omissions not in good faith or which involve intentional misconduct or a knowing violation of law, (iii) under Section 174 of the DGCL, or (iv) for any transaction from which the director derived an improper personal benefit. If the DGCL is amended to authorize corporate action further eliminating or limiting the personal liability of directors, then the liability of a director of the Corporation shall be eliminated or limited to the fullest extent permitted by the DGCL, as so amended.

Any repeal or modification of the foregoing paragraph shall not adversely affect any right or protection of a director of the Corporation existing at the time of such repeal or modification.

## **ARTICLE VII COMPLIANCE WITH GAMING LAWS**

Section 1. Definitions. For purposes of this Article VII, the following terms shall have the meanings specified below:

(a) "Affiliate" shall mean a Person who, directly or indirectly, through one or more intermediaries, controls, is controlled by or is under common control with, a specified Person. For the purpose of this Section 1(a) of Article VII, "control," "controlled by" and "under common control with" means the possession, direct or indirect, of the power to direct or cause the direction of the management and policies of a Person, whether through ownership of voting securities, by contract, or otherwise. "Affiliated Companies" shall mean those partnerships, corporations, limited liability companies, trusts or other entities that are Affiliates of the Corporation, including, without limitation, subsidiaries, holding companies and intermediary companies (as those and similar terms are defined in the Gaming Laws of the applicable Gaming Jurisdictions) that are registered or licensed under applicable Gaming Laws.

(b) "Gaming" or "Gaming Activities" shall mean the conduct of gaming and gambling activities, or the use of gaming devices, equipment and supplies in the operation of a gaming establishment or other enterprise, including, without limitation, race books, sports pools,

slot machines, gaming devices, lottery devices, gaming tables, cards, dice, gaming chips, player tracking systems, cashless wagering systems and associated equipment and supplies.

(c) “Gaming Authorities” shall mean all federal, state, provincial, tribal, local and other regulatory and licensing bodies and agencies with authority over Gaming within any Gaming Jurisdiction in which the Corporation or any of its Affiliated Companies do business.

(d) “Gaming Jurisdiction” shall mean all jurisdictions, domestic, tribal and foreign, and their political subdivisions, in which Gaming Activities are or may be lawfully conducted including, without limitation, all jurisdictions in which the Corporation or any of its Affiliated Companies currently conduct or may in the future conduct Gaming Activities.

(e) “Gaming Laws” shall mean all laws, statutes, ordinances and regulations pursuant to which any Gaming Authority possesses regulatory and licensing authority over Gaming within any Gaming Jurisdiction, and all orders, decrees, rules and regulations promulgated by such Gaming Authority thereunder.

(f) “Gaming Licenses” shall mean all licenses, permits, approvals, authorizations, registrations, findings of suitability, franchises, concessions and entitlements issued by a Gaming Authority necessary for or relating to the conduct of Gaming Activities.

(g) “Own,” “Ownership” or “Control” (and derivatives thereof) shall mean (i) ownership of record, (ii) “beneficial ownership” as defined in Rule 13d-3 promulgated by the United States Securities and Exchange Commission under the Securities Exchange Act of 1934, as amended (as now or hereafter amended) (“Rule 13d-3”), or (iii) the possession, direct or indirect, of the power to direct or cause the direction of the management and policies of a Person or the disposition of Securities, by agreement contract, agency or other manner.

(h) “Person” shall mean an individual, partnership, corporation, limited liability company, trust or any other entity.

(i) “Redemption Date” shall mean the date specified in the Redemption Notice as the date on which the shares of the Securities Owned or Controlled by an Unsuitable Person or an Affiliate of an Unsuitable Person are to be redeemed by the Corporation.

(j) “Redemption Notice” shall mean that notice of redemption given by the Corporation to an Unsuitable Person or an Affiliate of an Unsuitable Person pursuant to this Article VII. Each Redemption Notice shall set forth (i) the Redemption Date, (ii) the number and type of shares of the Securities to be redeemed, (iii) the Redemption Price and the manner of payment therefor, (iv) the place where any certificates for such shares shall be surrendered for payment and (v) any other requirements of surrender of the certificates, including how they are to be endorsed, if at all.

(k) “Redemption Price” shall mean the price to be paid by the Corporation for the Securities to be redeemed pursuant to this Article VII, which shall be that price (if any) required to be paid by the Gaming Authority making the finding of unsuitability, or if such Gaming Authority does not require a certain price to be paid that amount determined by the Board of Directors to be the fair value of the Securities to be redeemed; provided, however, that the price

per share represented by the Redemption Price shall in no event be in excess of the closing sales price per share of the shares on the principal national securities exchange on which such shares are then listed on the trading date on the day before the Redemption Notice is deemed given by the Corporation to the Unsuitable Person or Affiliate of an Unsuitable Person or, if such shares are not then listed for trading on any national securities exchange, then the closing sales price of such shares as quoted in the NASDAQ Stock Market or SmallCap Market or, if the shares are not then so quoted, then the mean between the representative bid and the ask price as quoted by any other generally recognized reporting system. The Redemption Price may be paid in cash, by promissory note, or both as required by the applicable Gaming Authority and, if not so required, as the Board of Directors determines. Any promissory note shall contain such terms and conditions as the Board of Directors determines necessary or advisable, including without limitation, subordination provisions, to comply with any law or regulation applicable to the Corporation or any Affiliate of the Corporation or to prevent a default under, breach of, event of default under or acceleration of any loan, promissory note, mortgage, indenture, line of credit or other debt or financing agreement of the Corporation or any Affiliate of the Corporation. Subject to the forgoing, the principal amount of the promissory note together with any unpaid interest shall be due and payable no later than the tenth anniversary of delivery of the note and interest on the unpaid principal thereof shall be payable annually in arrears at the rate of 2% per annum.

(l) “Securities” shall mean the capital stock of the Corporation as described in Article IV hereof.

(m) “Unsuitable Person” shall mean a Person who (i) is determined by a Gaming Authority to be unsuitable to Own or Control any Securities or unsuitable to be connected or affiliated with a Person engaged in Gaming Activities in a Gaming Jurisdiction, or (ii) causes the Corporation or any Affiliated Company to lose or to be threatened with the loss of any Gaming License, or (iii) in the sole discretion of the Board of Directors of the Corporation, is deemed likely to jeopardize the Corporation’s or any Affiliated Company’s application for, receipt of approval for, right to the use of, or entitlement to, any Gaming License.

## Section 2. Finding of Unsuitability.

(a) The Securities Owned or Controlled by an Unsuitable Person or an Affiliate of an Unsuitable Person shall be subject to redemption by the Corporation, out of funds legally available therefor, by action of the Board of Directors, to the extent deemed necessary or advisable by the Board of Directors. If a Gaming Authority requires the Corporation, or the Board of Directors deems it necessary or advisable, to redeem any such Securities, the Corporation shall give a Redemption Notice to the Unsuitable Person or its Affiliate and shall purchase on the Redemption Date the number of Shares of the Securities specified in the Redemption Notice for the Redemption Price set forth in the Redemption Notice. From and after the Redemption Date, such Securities shall no longer be deemed to be outstanding, such Unsuitable Person or any Affiliate of such Unsuitable Person shall cease to be a stockholder with respect to such shares and all rights of such Unsuitable Person or any Affiliate of such Unsuitable Person therein, other than the right to receive the Redemption Price, shall cease. Such Unsuitable Person or its Affiliate shall surrender all certificates representing any shares to be redeemed in accordance with the requirements of the Redemption Notice.

(b) Commencing on the date that a Gaming Authority serves notice of a determination of unsuitability or the Board of Directors determines that a Person is an Unsuitable Person, and until the Securities Owned or Controlled by such Person are Owned or Controlled by a Person who is not an Unsuitable Person, the Unsuitable Person or any Affiliate of an Unsuitable Person shall not be entitled to: (i) receive any dividend or interest with regard to the Securities, (ii) to exercise, directly or indirectly or through any proxy, trustee, or nominee, any voting or other right conferred by such Securities, and such Securities shall not for any purposes be included in the shares of capital stock of the Corporation entitled to vote, or (iii) receive any remuneration in any form from the Corporation or any Affiliated Company for services rendered or otherwise.

Section 3. Notices. All notices given by the Corporation pursuant to this Article, including Redemption Notices, shall be in writing and may be given by mail, addressed to the Person at such Person's address as it appears on the records of the Corporation, with postage thereon prepaid, and such notice shall be deemed given personally or by telegram, facsimile, telex or cable.

Section 4. Indemnification. Any Unsuitable Person and any Affiliate of and Unsuitable Person shall indemnify and hold harmless the Corporation and its Affiliated Companies for any and all losses, costs and expenses, including attorney's fees, incurred by the Corporation and its Affiliated Companies as a result of, or arising out of, such Unsuitable Person's or Affiliate's continuing Ownership or Control of Securities, the neglect, refusal or other failure to comply with the provisions of this Article VII, or failure to promptly divest itself of any Securities when required by the Gaming Laws or this Article VII.

Section 5. Injunctive Relief. The Corporation is entitled to injunctive or other equitable relief in any court of competent jurisdiction to enforce the provisions of this Article VII and each holder of the Securities of the Corporation shall be deemed to have acknowledged, by acquiring the Securities of the Corporation, that the failure to comply with this Article VII will expose the Corporation to irreparable injury for which there is not adequate remedy at law and that the Corporation is entitled to injunctive or other equitable relief to enforce the provisions of this Article.

Section 6. Non-exclusivity of Rights. The Corporation's rights of redemption provided in this Article VII shall not be exclusive of any other rights the Corporation may have or hereafter acquire under any agreement, provision of the Bylaws or otherwise.

Section 7. Further Actions. Nothing contained in this Article VII shall limit the authority of the Board of Directors to take such other action to the extent permitted by law as it deems necessary or advisable to protect the Corporation or its Affiliated Companies from the denial or threatened denial or loss or threatened loss of any Gaming License of the Corporation or any of its Affiliated Companies. Without limiting the generality of the forgoing, the Board of Directors may conform any provisions of this Article VII to the extent necessary to make such a provision consistent with Gaming Laws. In addition, the Board of Directors may, to the extent permitted by law, from time to time establish, modify, amend or rescind bylaws, regulations, and procedures of the Corporation not inconsistent with the express provisions of this Article VII for the purpose of determining whether any Person is an Unsuitable Person and for the orderly application, administration and implementation of the provisions of this Article VII. Such

procedures and regulations shall be kept on file with the Secretary of the Corporation, the Secretary of its Affiliated Companies and with the transfer agent, if any, of the Corporation and any Affiliated Companies, and shall be made available for inspection by the public and, upon request mailed to any holder of Securities. The Board of Directors shall have exclusive authority and power to administer this Article VII and to exercise all rights and powers specifically granted to the Board of Directors or the Corporation, or as may be necessary or advisable in the administration of this Article VII. All such actions which are done or made by the Board of Directors in good faith shall be final, conclusive and binding on the Corporation and all other Persons; provided, however, that the Board of Directors may delegate all or any portion of its duties and powers under this Article VII to a committee of the Board of Directors as it deems necessary or advisable.

Section 8. Severability. If any provision of this Article VII or the application of any such provision to any Person or under any circumstance shall be held invalid, illegal, or unenforceable in any respect by a court of competent jurisdiction, such invalidity, illegality or unenforceability shall not affect any other provision of this Article VII.

Section 9. Termination and Waivers. Except as may be required by any applicable Gaming Law or Gaming Authority, the Board of Directors may waive any of the rights of the Corporation or any restrictions contained in this Article VII in any instance in which the Board of Directors determines that a waiver would be in the best interests of the Corporation. The Board of Directors may terminate any rights of the Corporation or restrictions set forth in this Article VII to the extent that the Board of Directors determines that any such termination is in the best interests of the Corporation. Except as may be required by a Gaming Authority, nothing in this Article VII shall be deemed or construed to require the Corporation to repurchase any Securities Owned or Controlled by an Unsuitable Person of an Affiliate of an Unsuitable Person.

Section 10. Required New Jersey Charter Provisions.

(a) These Articles shall be deemed to include all provisions required by the New Jersey Casino Control Act, N.J.S.A. 5:12-1 et seq., as amended from time to time (the "New Jersey Act") and, to the extent that anything contained herein or in the Bylaws of the Corporation is inconsistent with the New Jersey Act, the provisions of the New Jersey Act shall govern. All provisions of the New Jersey Act, to the extent required by law to be stated in these Articles, are incorporated herein by this reference.

(b) These Articles shall be subject to the provisions of the New Jersey Act and the rules and regulations of the New Jersey Casino Control Commission (the "New Jersey Commission") promulgated thereunder. Specifically, and in accordance with the provisions of Section 82(d)(7) of the New Jersey Act, the Securities of the Corporation are held subject to the condition that, if a holder thereof is found to be disqualified by the New Jersey Commission pursuant to the provisions of the New Jersey Act, the holder must dispose of such Securities in accordance with Section 2(a) of this Article VII and shall be subject to Section 2(b) of this Article VII.

(c) Any newly elected or appointed director or officer of, or nominee to any such position with, the Corporation, who is required to qualify pursuant to the New Jersey Act, shall not exercise any powers of the office to which such individual has been elected, appointed or

nominated until such individual has been found qualified to hold such office or position by the New Jersey Commission in accordance with the New Jersey Act or the New Jersey Commission permits such individual to perform duties and exercise powers relating to any such position pending qualification, with the understanding that such individual will be immediately removed from such position if the New Jersey Commission determines that there is reasonable cause to believe that such individual may not be qualified to hold such position.

## **ARTICLE VIII SHAREHOLDERS RIGHTS PLAN**

Any Rights Plan adopted by the Board of Directors shall have a triggering “Acquiring Person” beneficial ownership threshold of 25% or higher. If the Board of Directors adopts a Rights Plan, such Rights Plan will be put to a vote of stockholders within 135 days of the date of adoption of such Rights Plan (the “135th Day Deadline”). If the Corporation fails to hold a stockholder vote on or prior to the 135th Day Deadline, then the Rights Plan shall automatically terminate on the 135th Day Deadline. If a stockholder vote is held on the Rights Plan and it is not approved by the holders of a majority of shares voted, then the Rights Plan shall expire on a date not later than the 135th Day Deadline. “Rights Plan” shall mean any plan or arrangement of the sort commonly referred to as a “rights plan” or “stockholder rights plan” or “shareholder rights plan” or “poison pill” that is designed to increase the cost to a potential acquirer of exceeding the applicable ownership thresholds through the issuance of Common Stock, new rights or preferred shares (or any other security or device that may be issued to stockholders of the Corporation, other than ratably to all stockholders of the Corporation) that carry severe redemption provisions, favorable purchase provisions or otherwise, and any related rights agreement. The term “beneficial ownership” as used in the Rights Plan shall mean beneficial ownership as such term is defined in Rule 13d-3.

## **ARTICLE IX BYLAWS**

The Board of Directors is expressly empowered to adopt, amend or repeal the Bylaws of the Corporation. Any adoption, amendment or repeal of the Bylaws of the Corporation by the Board of Directors shall require the approval of a majority of the Whole Board. The stockholders shall also have power to adopt, amend or repeal the Bylaws of the Corporation; provided, however, that, in addition to any vote of the holders of any class or series of stock of the Corporation required by law or by this Certificate of Incorporation, the affirmative vote of the holders of a majority of the voting power of all of the then outstanding shares of the capital stock of the Corporation entitled to vote thereon, shall be required to adopt, amend or repeal any provision of the Bylaws of the Corporation. For purposes of this Certificate of Incorporation, the term “Whole Board” shall mean the total number of authorized directors whether or not there exist any vacancies in previously authorized directorships.

## **ARTICLE X AMENDMENTS**

The Corporation reserves the right to amend or repeal any provision contained in this Certificate of Incorporation in the manner prescribed by the laws of the State of Delaware and all rights



conferred upon stockholders are granted subject to this reservation; provided, however, that, notwithstanding any other provision of this Certificate of Incorporation or any provision of law that might otherwise permit a lesser vote or no vote, but in addition to any vote of the holders of any class or series of the stock of this corporation required by law or by this Certificate of Incorporation, and the affirmative vote of the holders of majority of the voting power of all of the then-outstanding shares of the capital stock of the Corporation entitled to vote thereon, shall be required to amend or repeal this Article X, Sections C or D of Article V, Article VI, or Article IX.

#### **ARTICLE XI SECTION 203**

The Corporation shall not be governed by or subject to the provisions of Section 203 of the DGCL as now in effect or hereafter amended, or any successor statute thereto.

#### **ARTICLE XII MANDATORY FORUM FOR ADJUDICATION OF DISPUTES**

Unless the Corporation consents in writing to the selection of an alternative forum, the Court of Chancery of the State of Delaware (the “Court of Chancery”) shall be the sole and exclusive forum for any stockholder (including a beneficial owner) to bring (i) any derivative action or proceeding brought on behalf of the Corporation, (ii) any action asserting a claim of breach of a fiduciary duty owed by any director, officer or other employee of the Corporation to the Corporation or the Corporation’s stockholders, (iii) any action asserting a claim against the Corporation, its directors, officers or employees arising pursuant to any provision of the General Corporation Law of the State of Delaware or the Corporation’s Certificate of Incorporation or bylaws, or (iv) any action asserting a claim against the Corporation, its directors, officers or employees governed by the internal affairs doctrine, except as to each of (i) through (iv) above, for any claim as to which the Court of Chancery determines that there is an indispensable party not subject to the jurisdiction of the Court of Chancery (and the indispensable party does not consent to the personal jurisdiction of the Court of Chancery within ten days following such determination), which is vested in the exclusive jurisdiction of a court or forum other than the Court of Chancery, or for which the Court of Chancery does not have subject matter jurisdiction. If any provision or provisions of this Article XII shall be held to be invalid, illegal or unenforceable as applied to any person or entity or circumstance for any reason whatsoever, then, to the fullest extent permitted by law, the validity, legality and enforceability of such provisions in any other circumstance and of the remaining provisions of this Article XII (including, without limitation, each portion of any sentence of this Article XII containing any such provision held to be invalid, illegal or unenforceable that is not itself held to be invalid, illegal or unenforceable) and the application of such provision to other persons or entities and circumstances shall not in any way be affected or impaired thereby.

#### **ARTICLE XIII SEVERABILITY**

If any provision or provisions of these Articles shall be held to be invalid, illegal or unenforceable as applied to any person or entity or circumstance for any reason whatsoever, then, to the fullest extent permitted by law, the validity, legality and enforceability of such provision or

provisions in any other circumstance and of the remaining provisions of these Articles (including, without limitation, each portion of any paragraph of these Articles containing any such provision held to be invalid, illegal or unenforceable that is not itself held to be invalid, illegal or unenforceable) and the application of such provision or provisions to other persons, entities and circumstances shall not in any way be affected or impaired thereby.

**ARTICLE XIV  
DEEMED NOTICE AND CONSENT**

To the fullest extent permitted by law, each and every natural person, corporation, general or limited partnership, limited liability company, joint venture, trust, association or any other entity purchasing or otherwise acquiring any interest (of any nature whatsoever) in any shares of the capital stock of the Corporation shall be deemed, by reason of and from and after the time of such purchase or other acquisition, to have notice of and to have consented to all of the provisions of (a) these Articles (including but not limited to Article X), (b) the Bylaws and (c) any amendment to these Articles or the Bylaws enacted or adopted in accordance with these Articles, the Bylaws and applicable law.

**ARTICLE XV  
INCORPORATOR**

The name and mailing address of the incorporator is Edmund L. Quatmann, Jr., 100 West Liberty Street, Suite 1150, Reno, Nevada 89501.

WITNESS my signature this 20 day of July, 2020.

DocuSigned by:

*Edmund L. Quatmann, Jr.*

E9DBB5C94EF143B...

Sole Incorporator

**Exhibit I – Caesars Entertainment Amendment to  
the Certificate of Incorporation**

# Delaware

Page 1

The First State

*I, JEFFREY W. BULLOCK, SECRETARY OF STATE OF THE STATE OF DELAWARE, DO HEREBY CERTIFY THE ATTACHED IS A TRUE AND CORRECT COPY OF THE CERTIFICATE OF AMENDMENT OF "CAESARS ENTERTAINMENT, INC.", FILED IN THIS OFFICE ON THE SEVENTEENTH DAY OF JUNE, A.D. 2021, AT 4:30 O`CLOCK P.M.*



  
Jeffrey W. Bullock, Secretary of State

3272809 8100  
SR# 20212483536

Authentication: 203476056  
Date: 06-17-21

You may verify this certificate online at [corp.delaware.gov/authver.shtml](http://corp.delaware.gov/authver.shtml)

**CERTIFICATE OF AMENDMENT OF CERTIFICATE OF INCORPORATION OF  
CAESARS ENTERTAINMENT, INC.**

Caesars Entertainment, Inc. (the "Corporation"), a corporation organized and existing under the General Corporation Law of the State of Delaware, hereby certifies as follows:

1. This Certificate of Amendment (the "Certificate of Amendment") amends the provisions of the Corporation's Certificate of Incorporation filed with the Secretary of State on July 20, 2020 (the "Certificate of Incorporation").

2. Article IV of the Certificate of Incorporation is hereby amended and restated in its entirety as follows:

The Corporation is authorized to issue five hundred million (500,000,000) shares of Common Stock having a par value of \$0.00001 per share (hereinafter referred to as "Common Stock"). Each outstanding share of Common Stock shall entitle the holder thereof to one vote on each matter properly submitted to the shareholders of the Corporation for their vote.


The Corporation is further authorized to issue 150,000,000 shares of Preferred Stock at par value of \$0.00001 per share. The Board of Directors is hereby expressly authorized to provide, out of the unissued shares of preferred stock, for one or more series of preferred stock and, with respect to each such series, to fix the number of shares constituting such series and the designation of such series, the voting powers, if any, of the shares of such series, and the preferences and relative, participating, optional or other special rights, if any, and any qualifications, limitations or restrictions thereof, of the shares of such series. The powers, preferences and relative, participating, optional and other special rights of each series of preferred stock, and the qualifications, limitations or restrictions thereof, if any, may differ from those of any and all other series at any time outstanding.

3. This amendment was duly adopted in accordance with the provisions of Section 242 of the General Corporation Law of the State of Delaware.

4. All other provisions of the Certificate of Incorporation shall remain in full force and effect.

IN WITNESS WHEREOF, the Corporation has caused this Certificate of Amendment to be signed by its duly authorized officer on this 17<sup>th</sup> day of June, 2021.

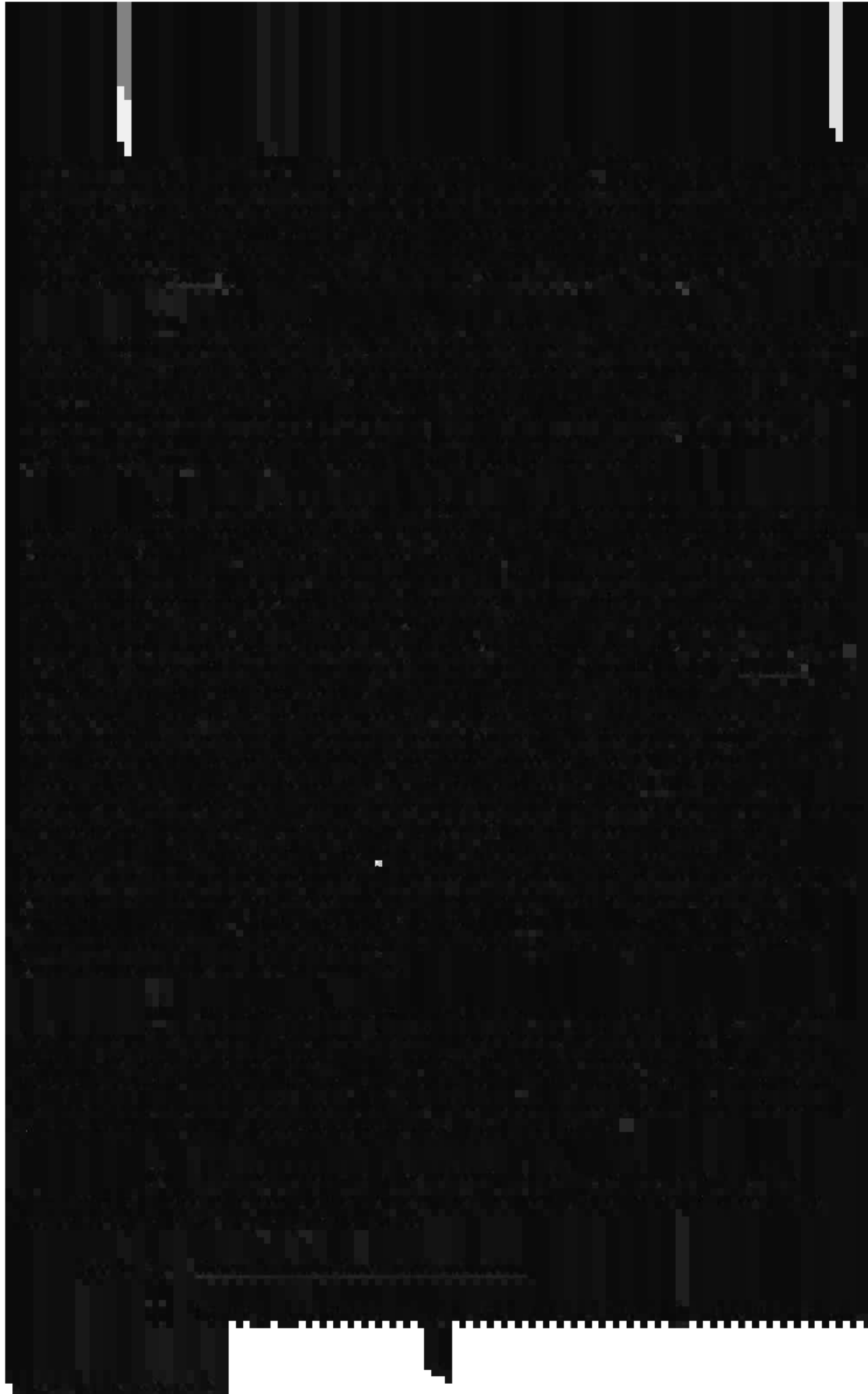
CAESARS ENTERTAINMENT, INC.

DocuSigned by:  
  
By FA7F02C3AB2D4F1...  
Name: Edmund Quatmann, Jr.  
Title: Chief Legal Officer, Executive Vice  
President and Secretary

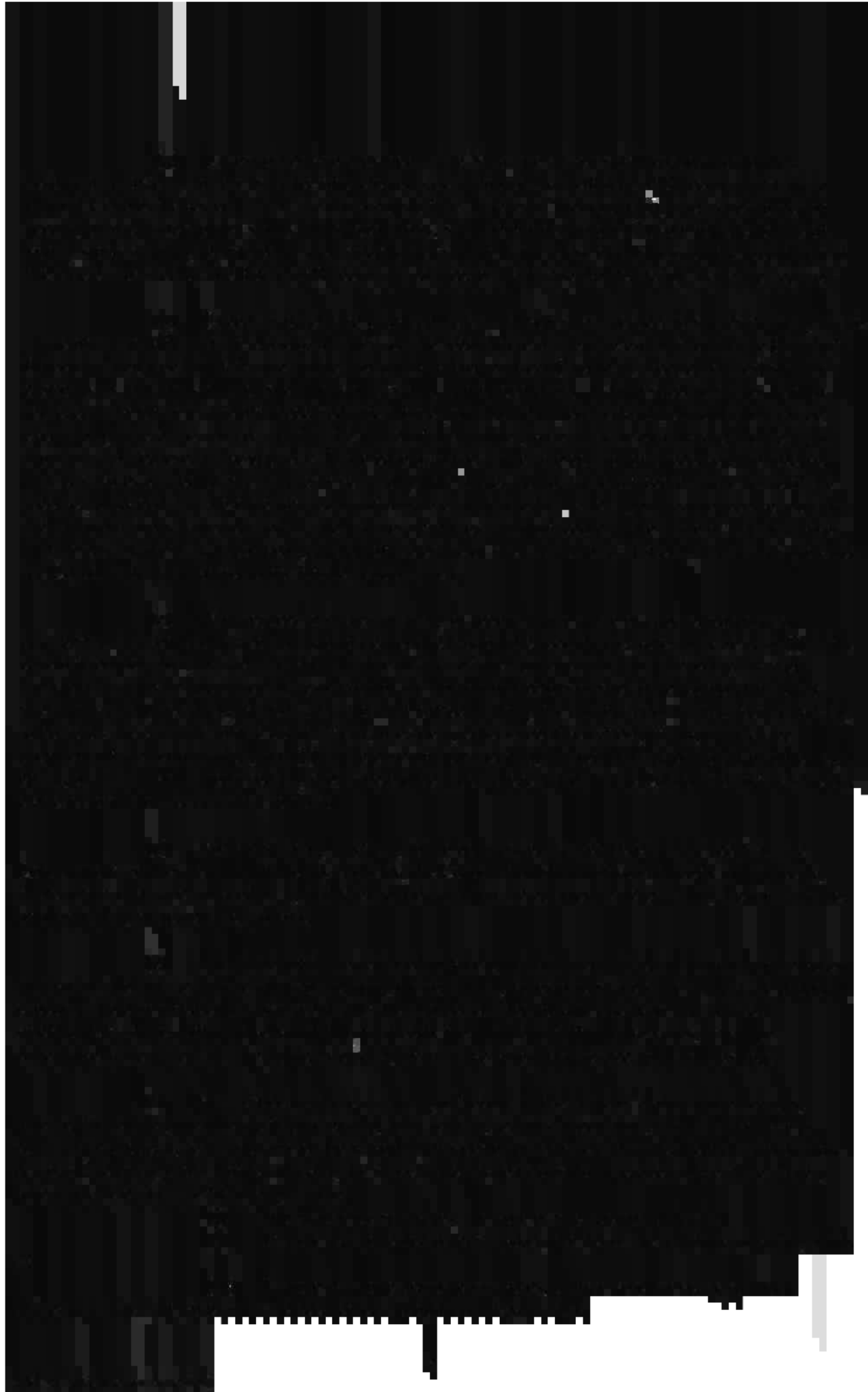
**Exhibit J – American Wagering, Inc. – Bylaws 5th  
A&R**

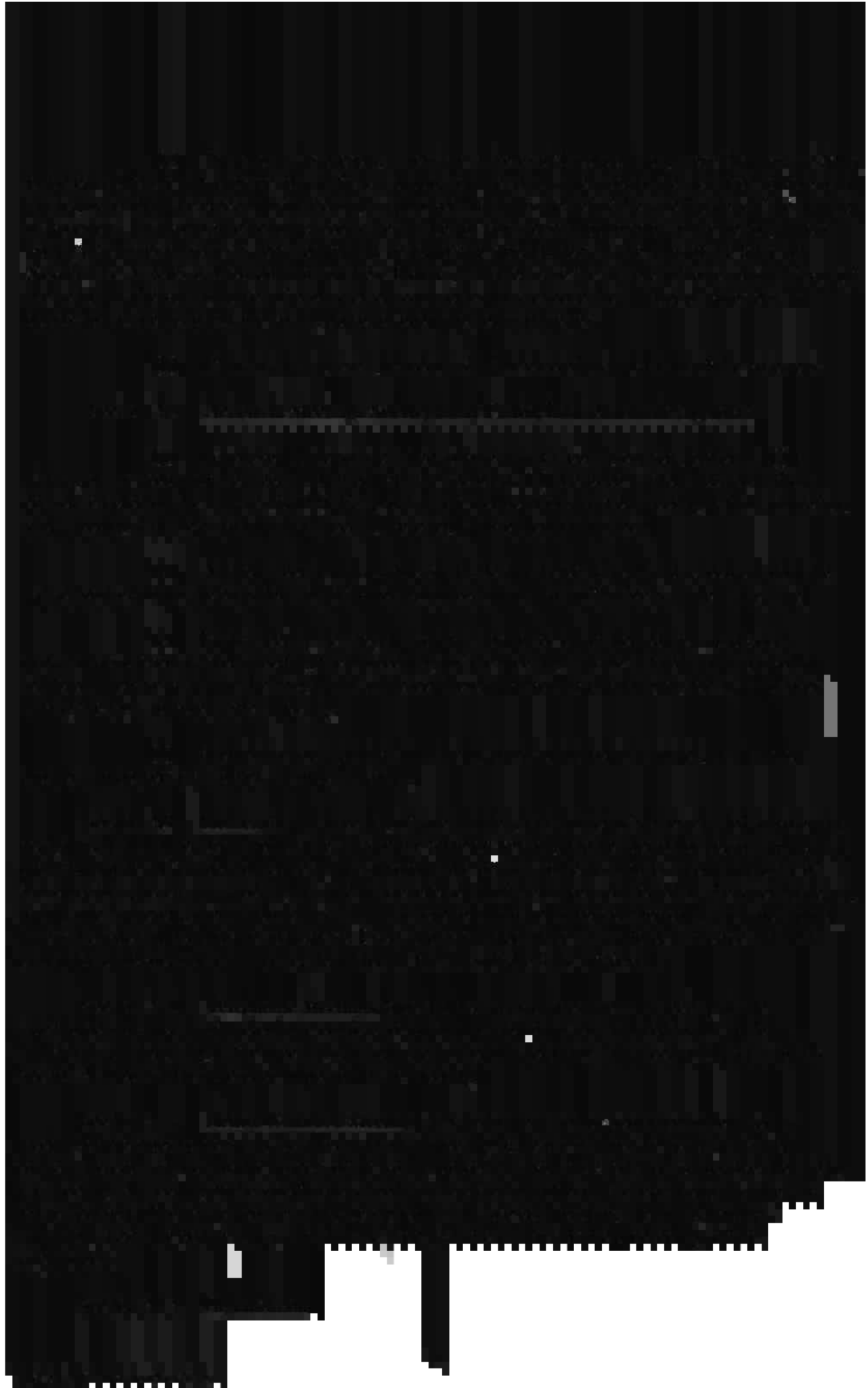












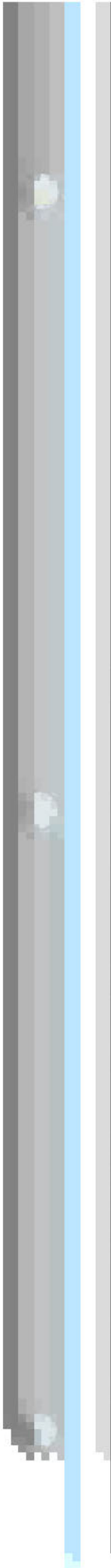
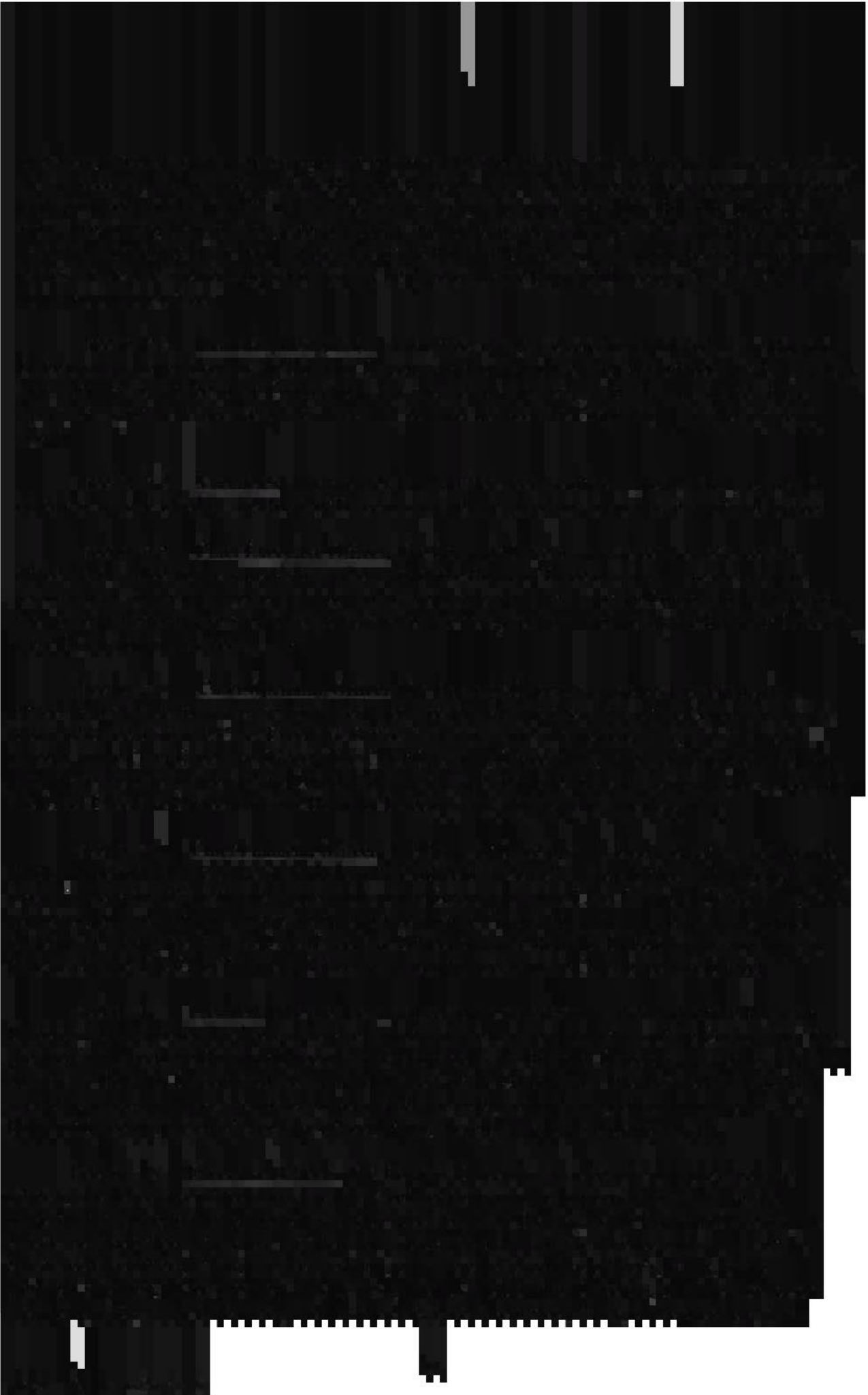












1. The first part of the document discusses the importance of maintaining accurate records of all transactions and activities. It emphasizes that this is crucial for ensuring transparency and accountability in the organization's operations.

2. The second part of the document outlines the various methods and tools used to collect and analyze data. It highlights the need for consistent and reliable data collection processes to ensure the validity of the results.

3. The third part of the document describes the different types of data that are collected and how they are used to inform decision-making. It notes that a combination of quantitative and qualitative data is often used to provide a comprehensive view of the organization's performance.

4. The fourth part of the document discusses the challenges and limitations of data collection and analysis. It acknowledges that there are often obstacles to obtaining complete and accurate data, and that the analysis of large volumes of data can be complex and time-consuming.

5. The fifth part of the document provides a summary of the key findings and conclusions of the study. It emphasizes the importance of ongoing monitoring and evaluation to ensure that the organization remains on track and is able to adapt to changing circumstances.

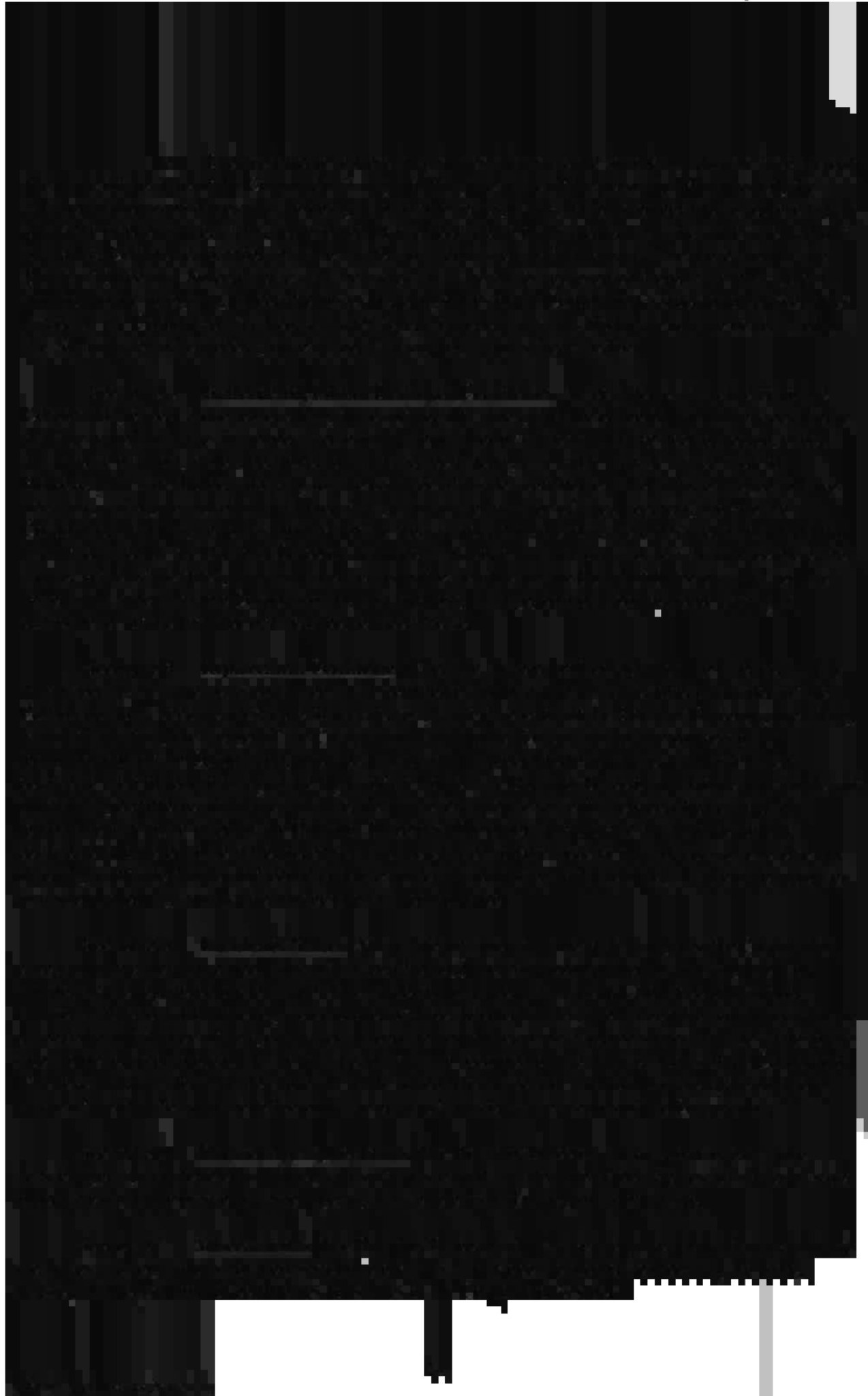
6. The sixth part of the document discusses the implications of the findings for the organization's future operations. It suggests that the data collected can be used to identify areas for improvement and to develop strategies to address any identified weaknesses.

7. The seventh part of the document provides a list of references and sources used in the study. It includes a range of academic journals, books, and reports that have informed the research and analysis.

8. The eighth part of the document contains a list of appendices and supplementary materials. These include detailed data tables, charts, and other supporting information that provide further context and detail for the findings.

9. The ninth part of the document provides a list of contact information for the authors and the organization. It includes email addresses and phone numbers for those who wish to request further information or discuss the findings in more detail.

[The page is almost entirely obscured by a large black redaction box. Only faint, illegible markings are visible through the redaction.]







1870

1871

1872

1873

1874

1875

1876

1877

1878

1879

1880

1881

1882

1883

1884

1885

1886

1887

1888

1889

1890

1891

1892

1893

1894

1895

1896

1897

1898

1899

[REDACTED]

[REDACTED]

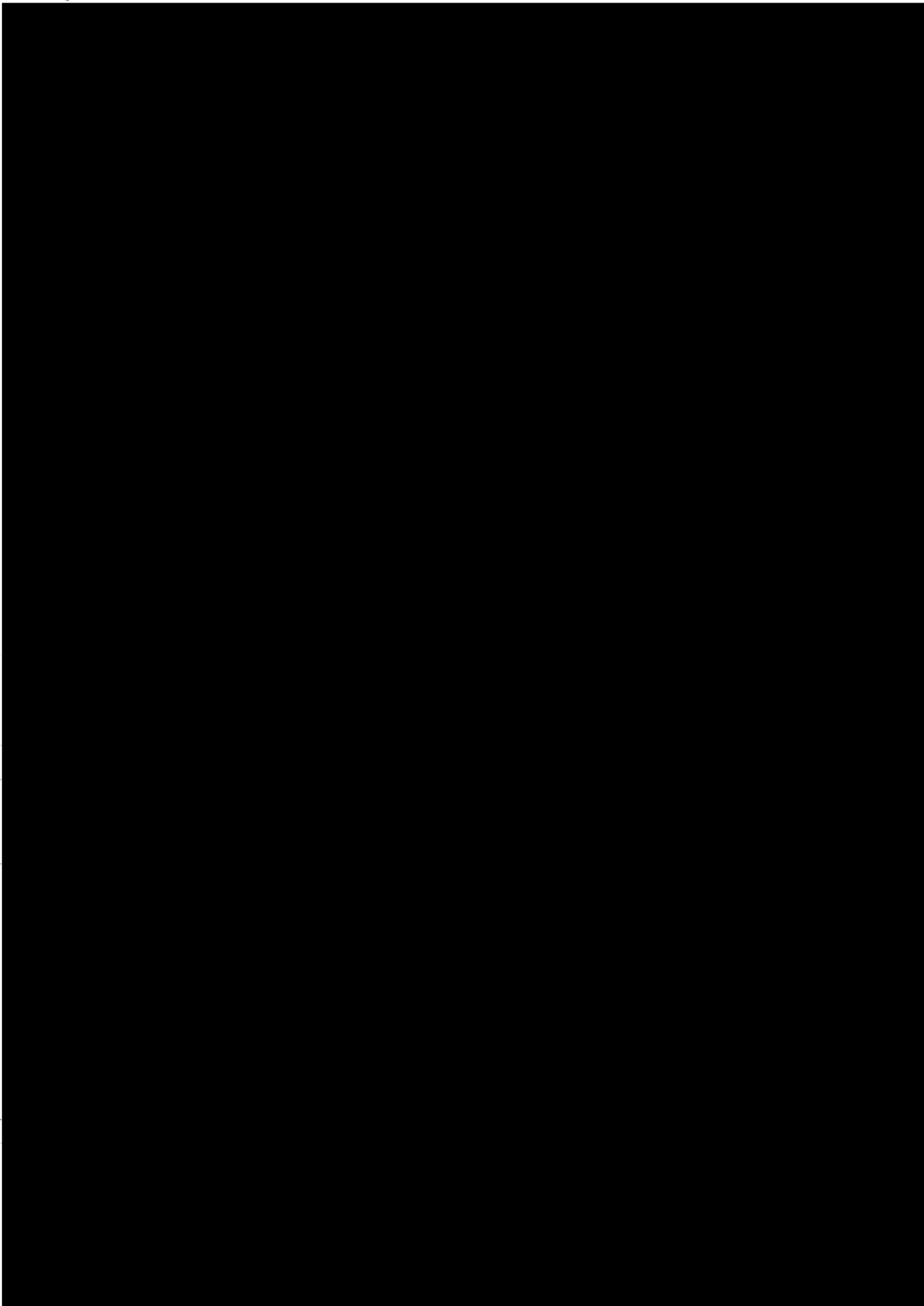
[REDACTED]

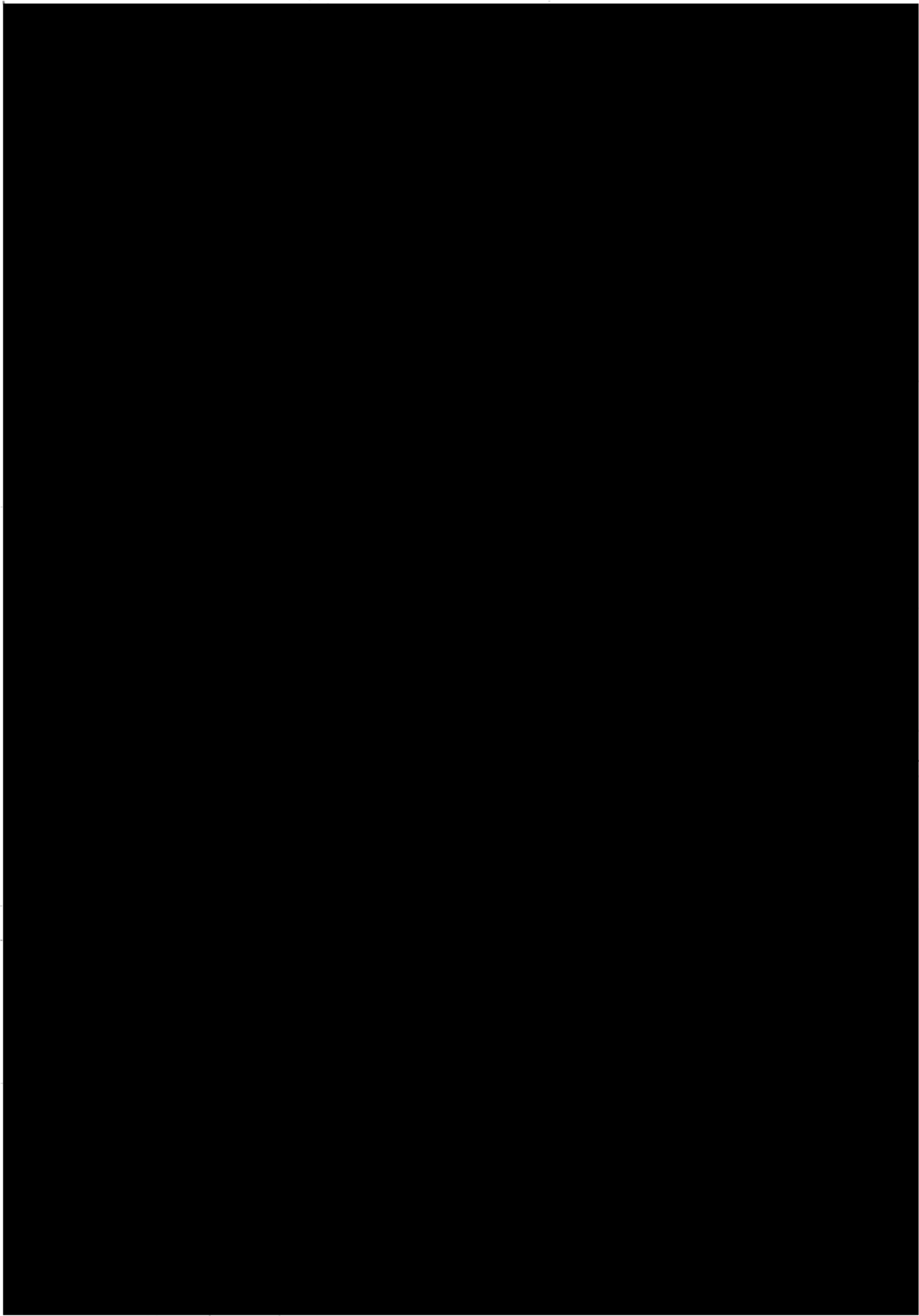
[REDACTED]

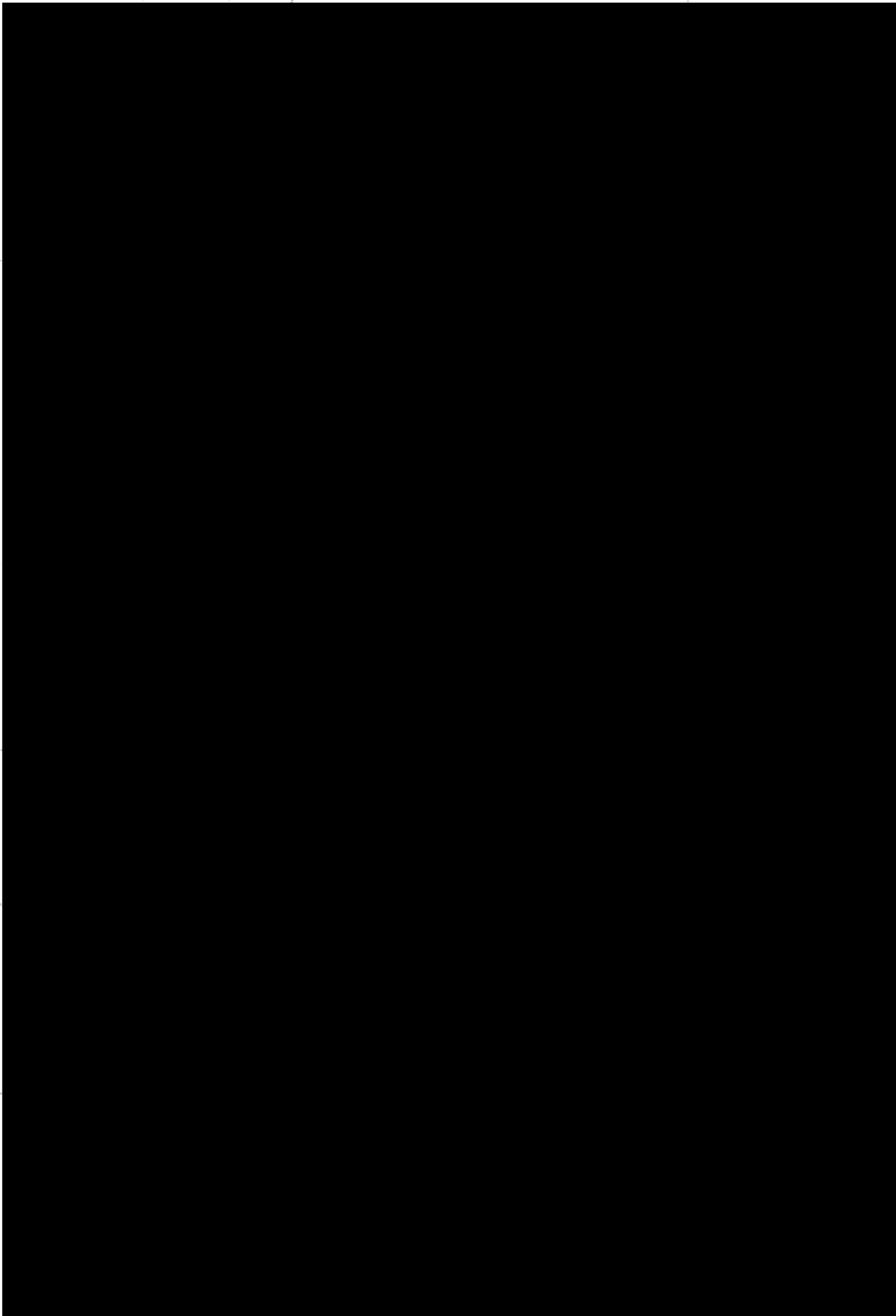


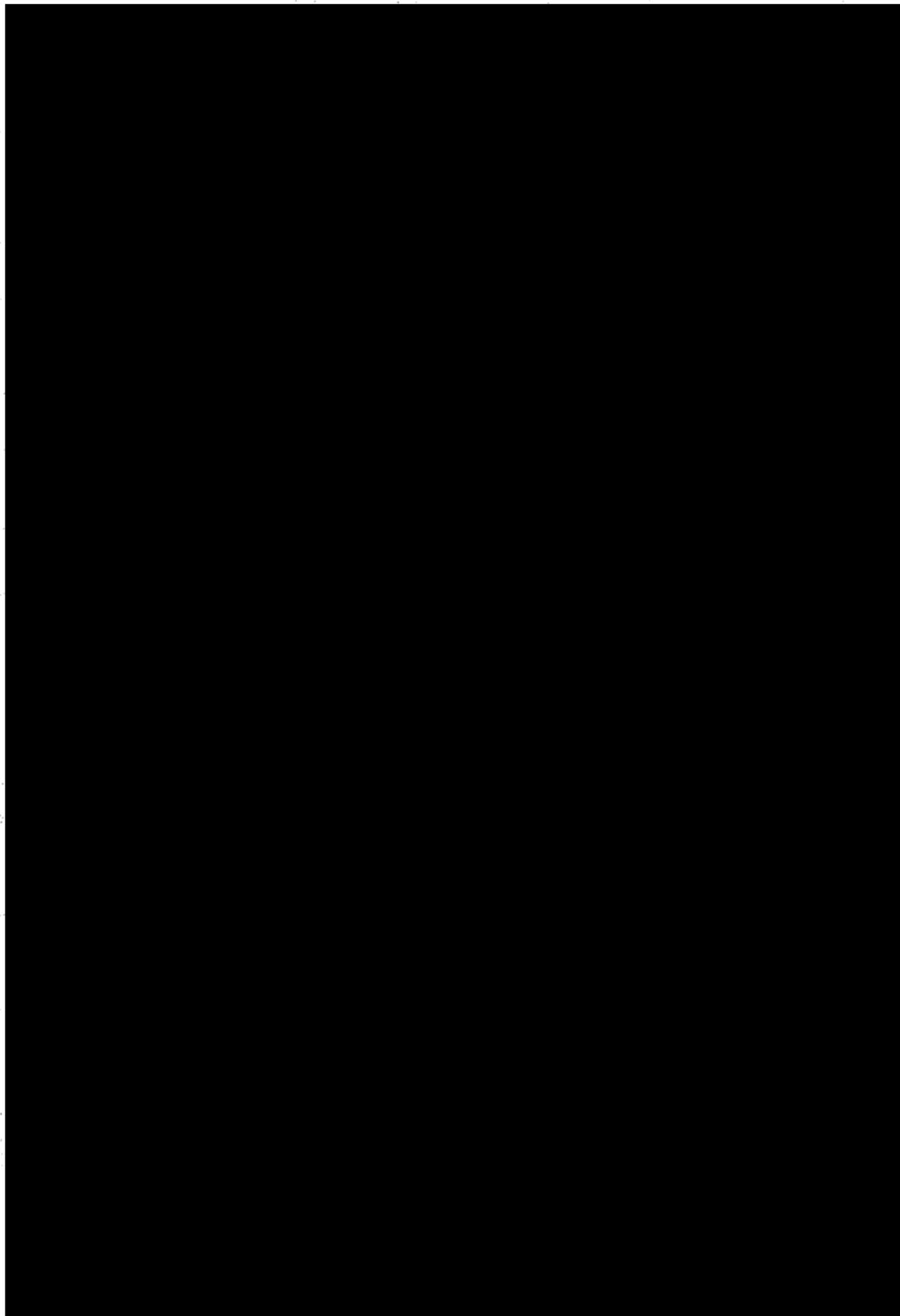


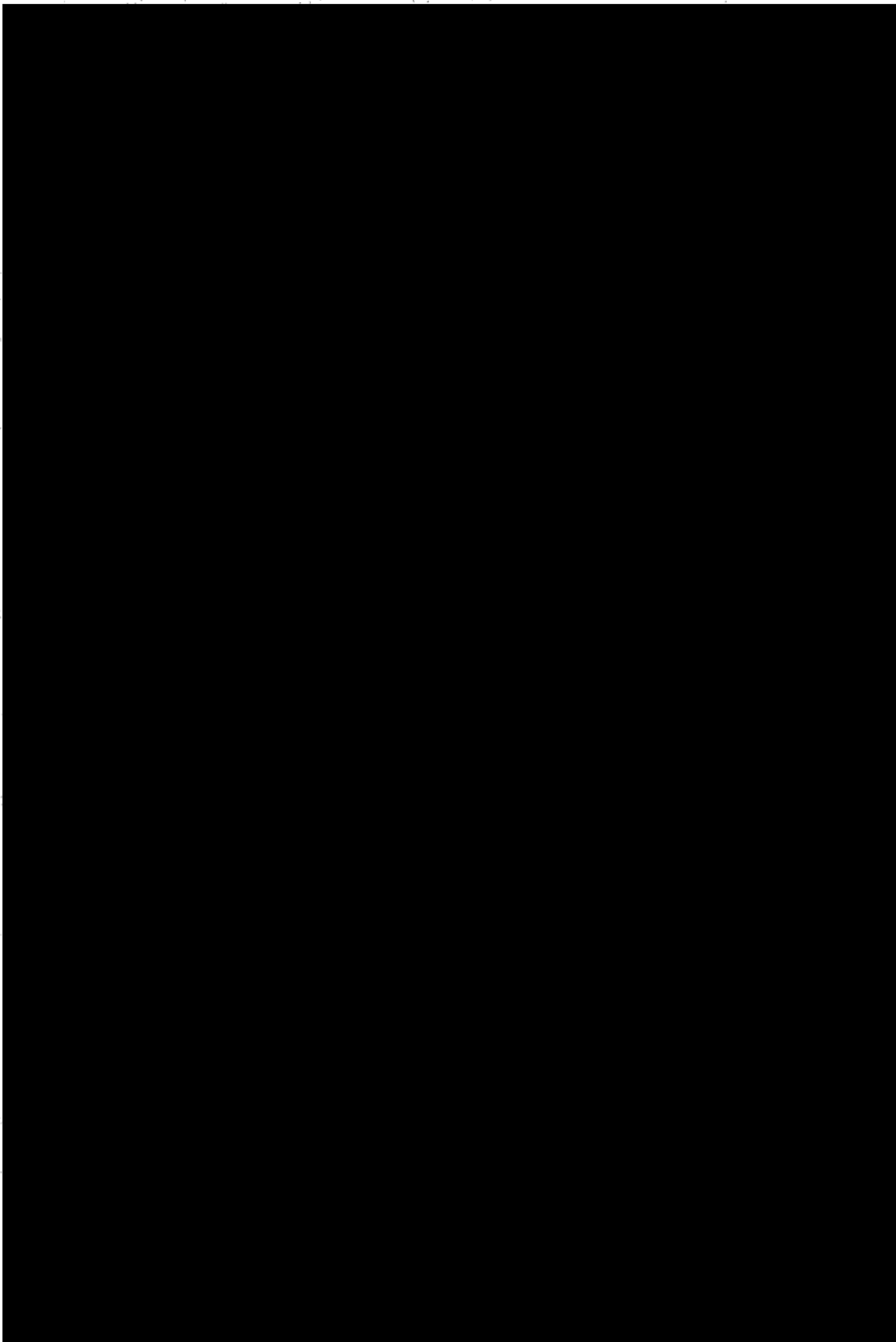
**Exhibit K – William Hill US Holdco-2nd Amended  
Bylaws**

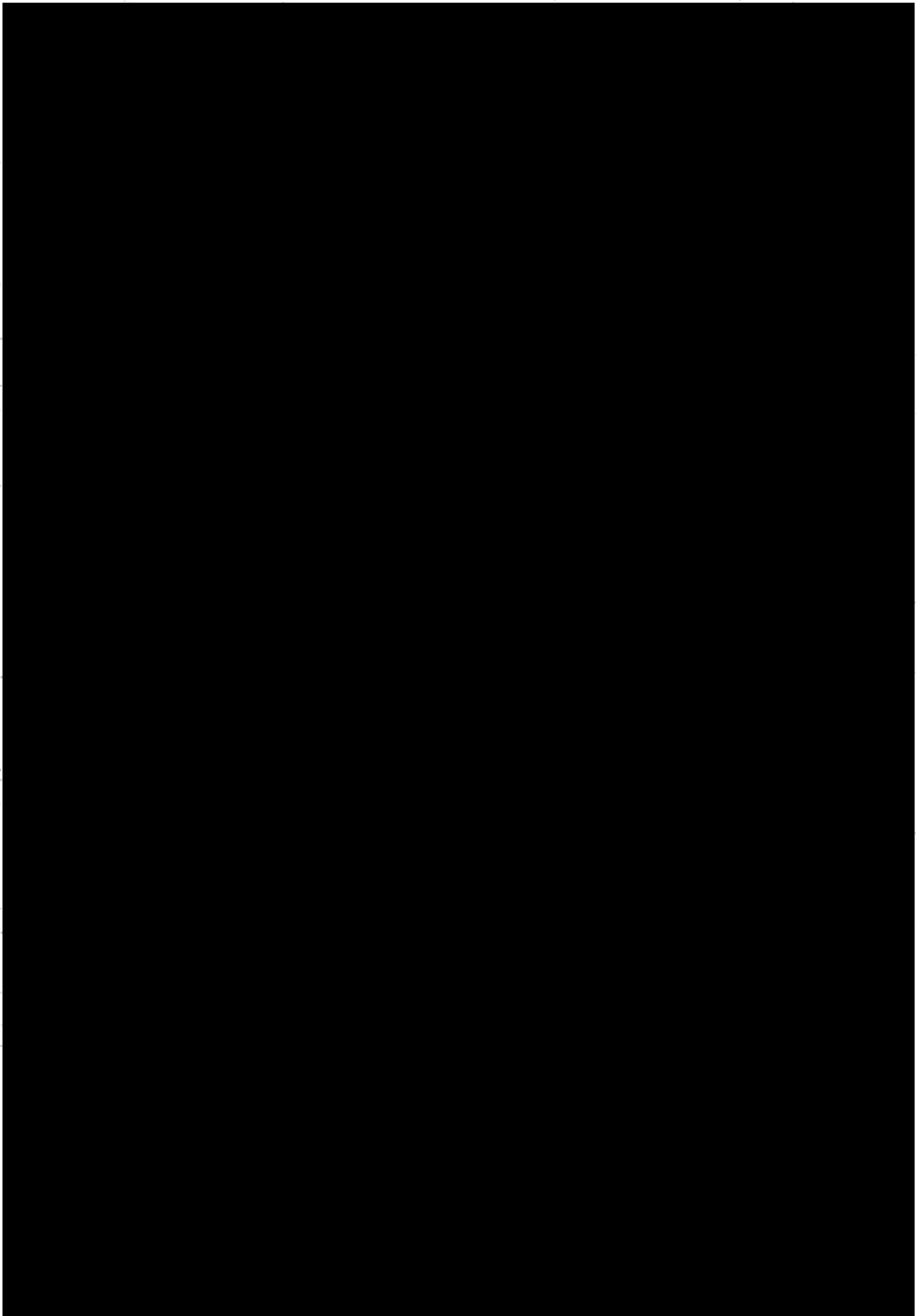




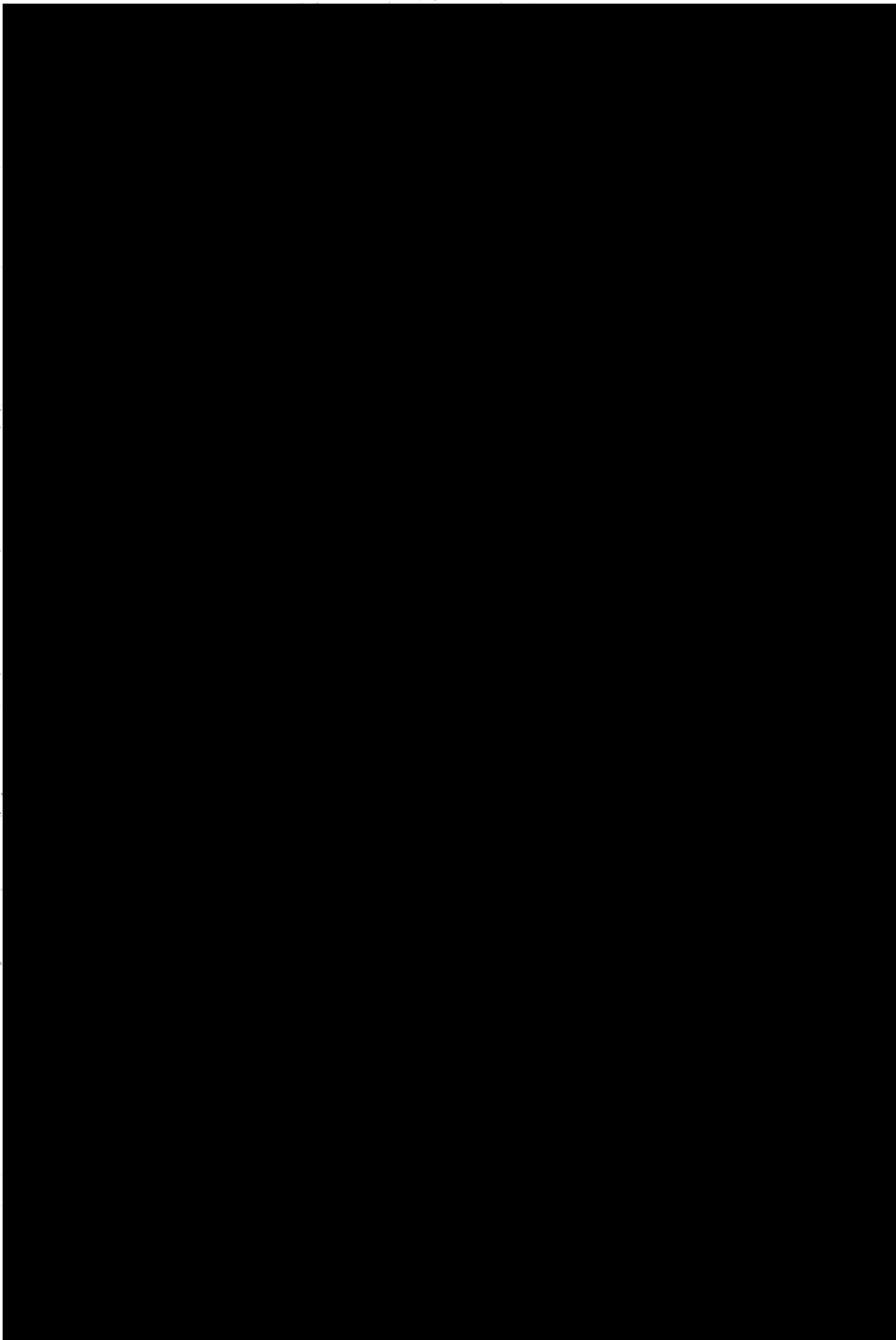


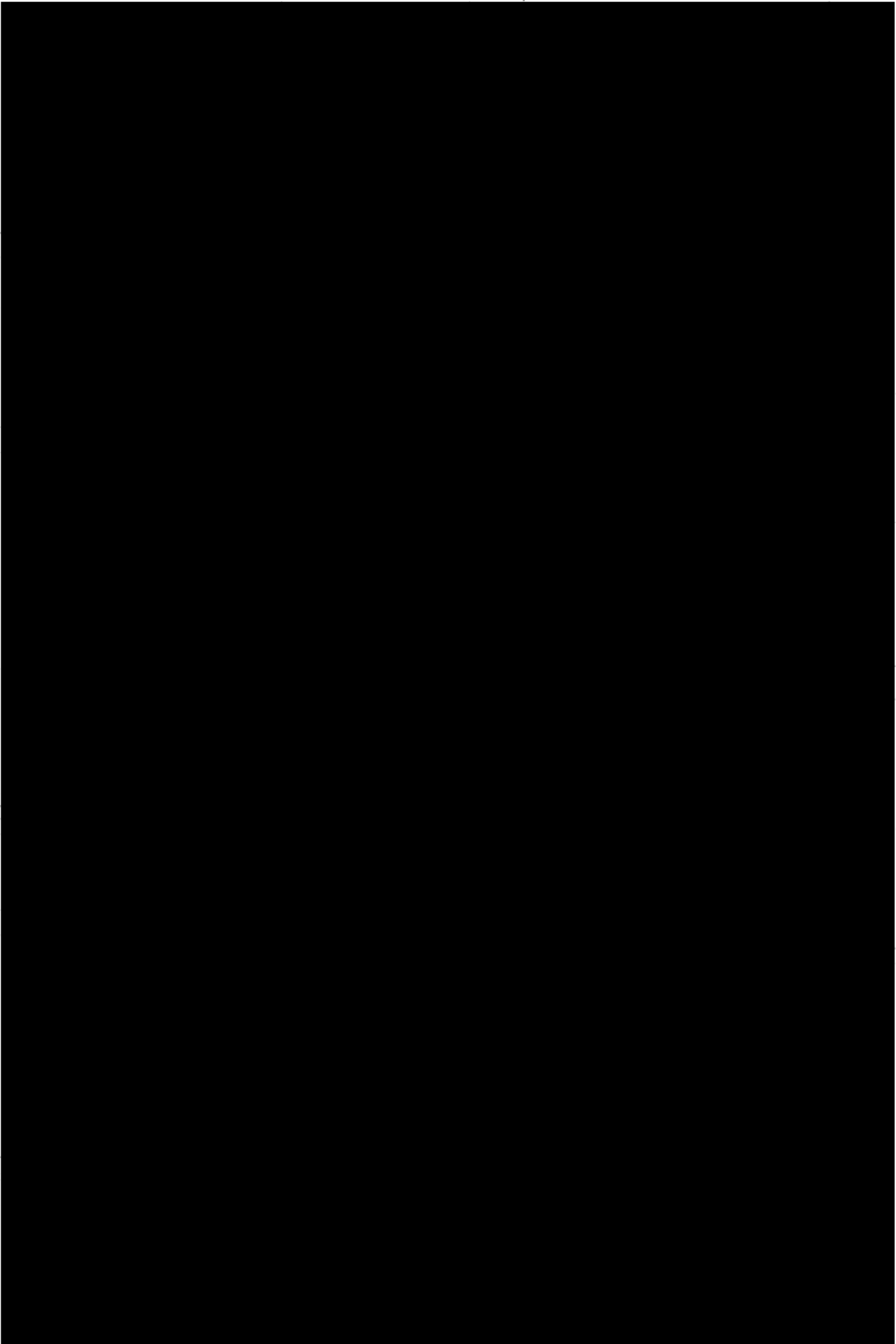


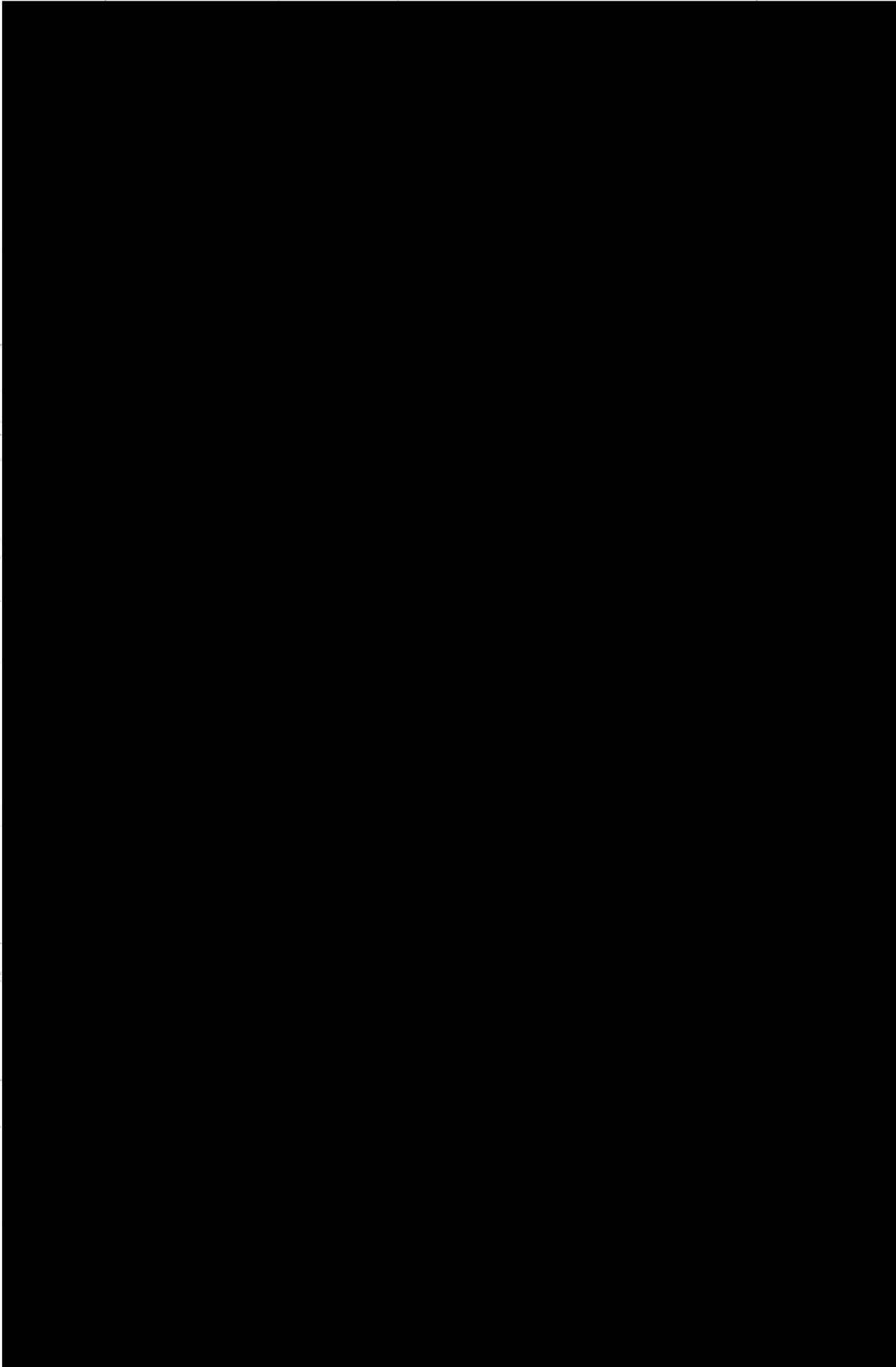


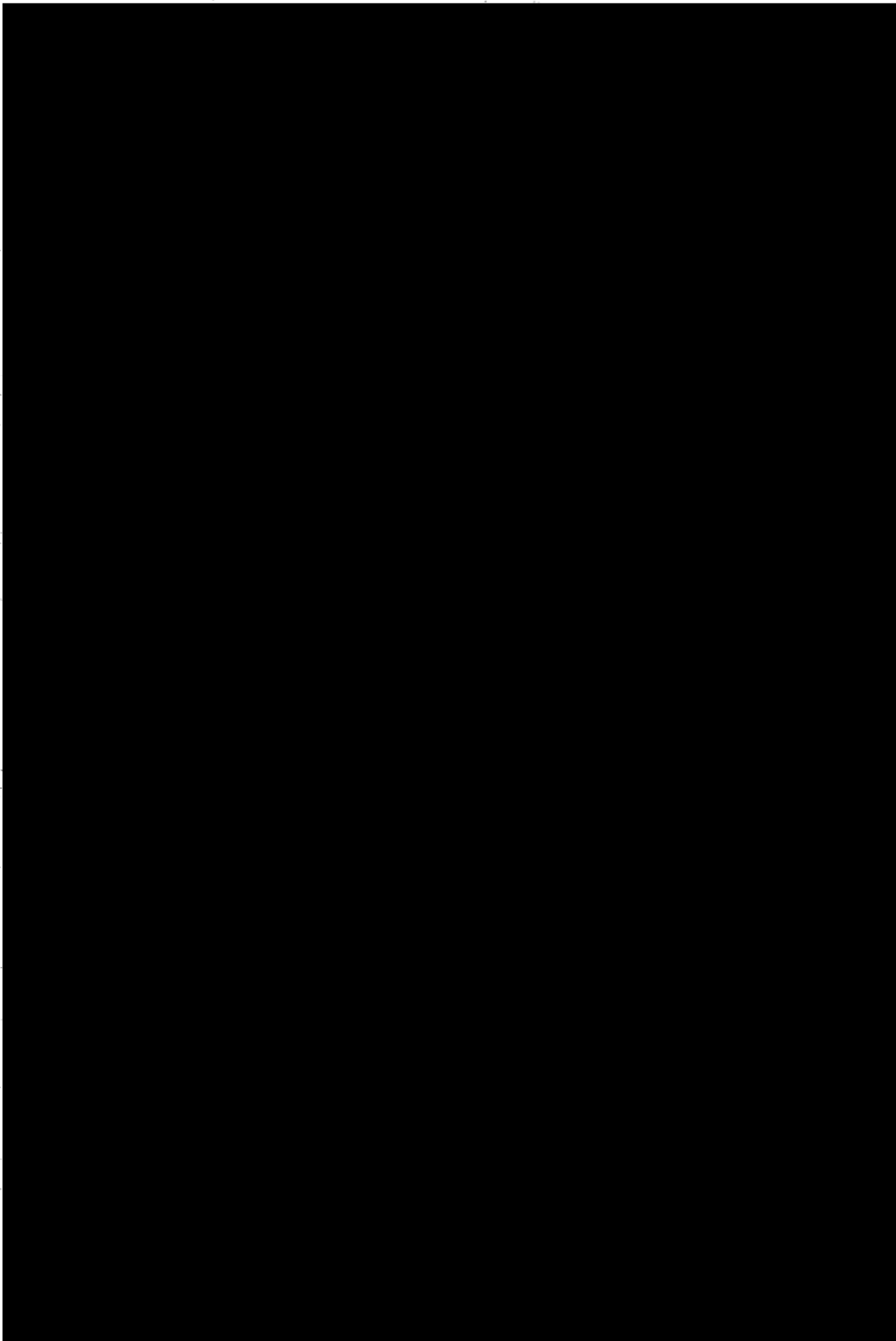


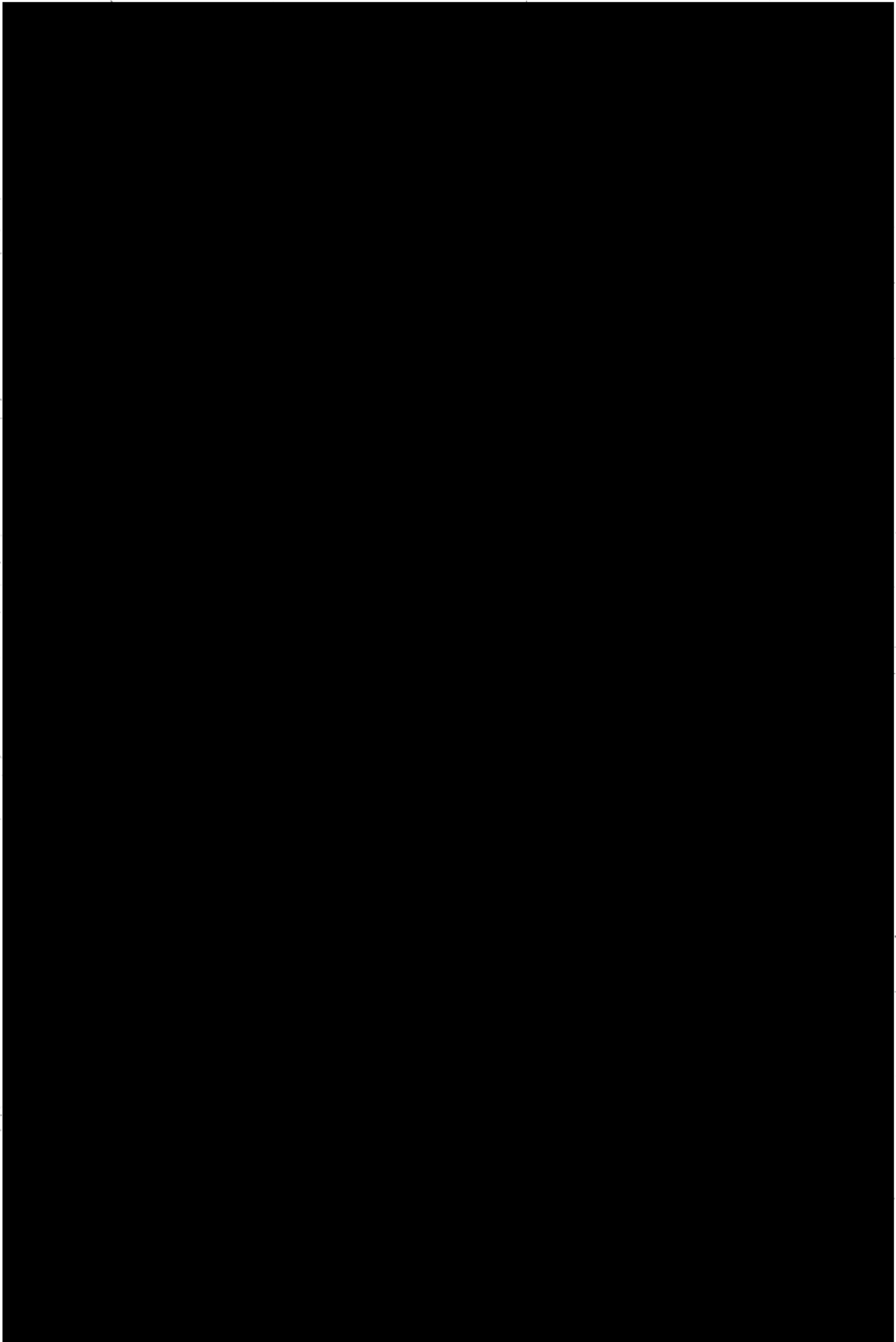


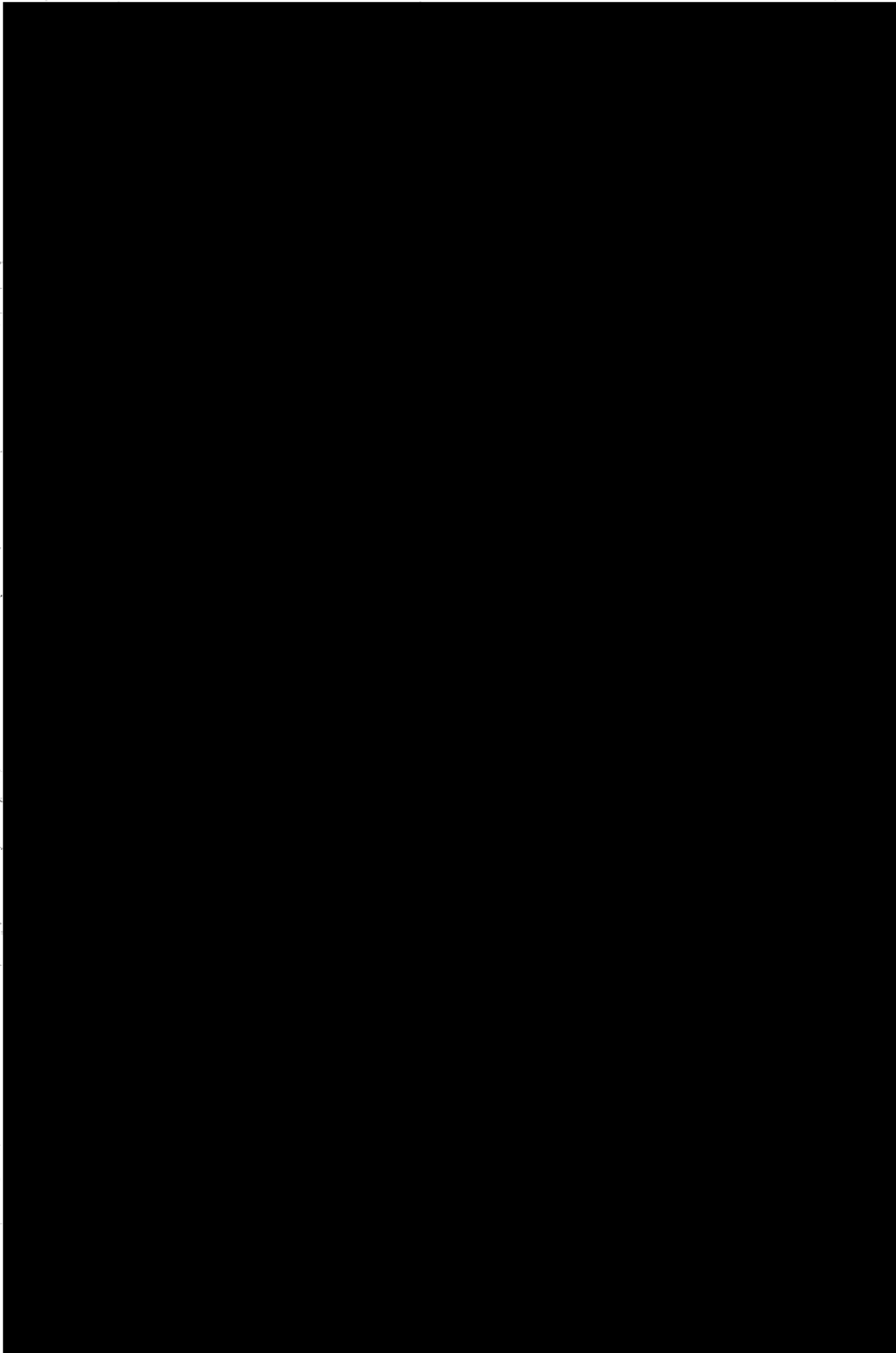


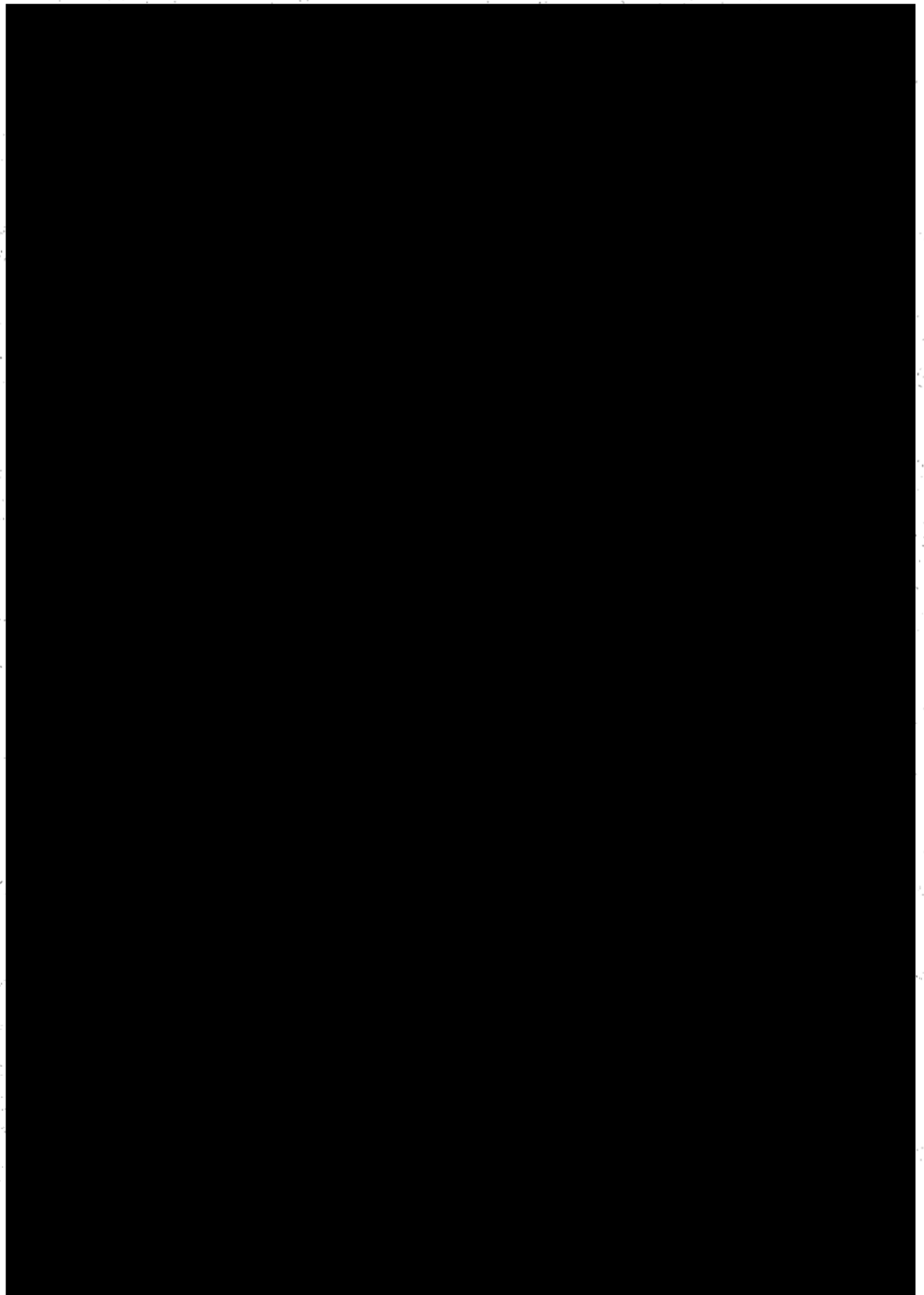


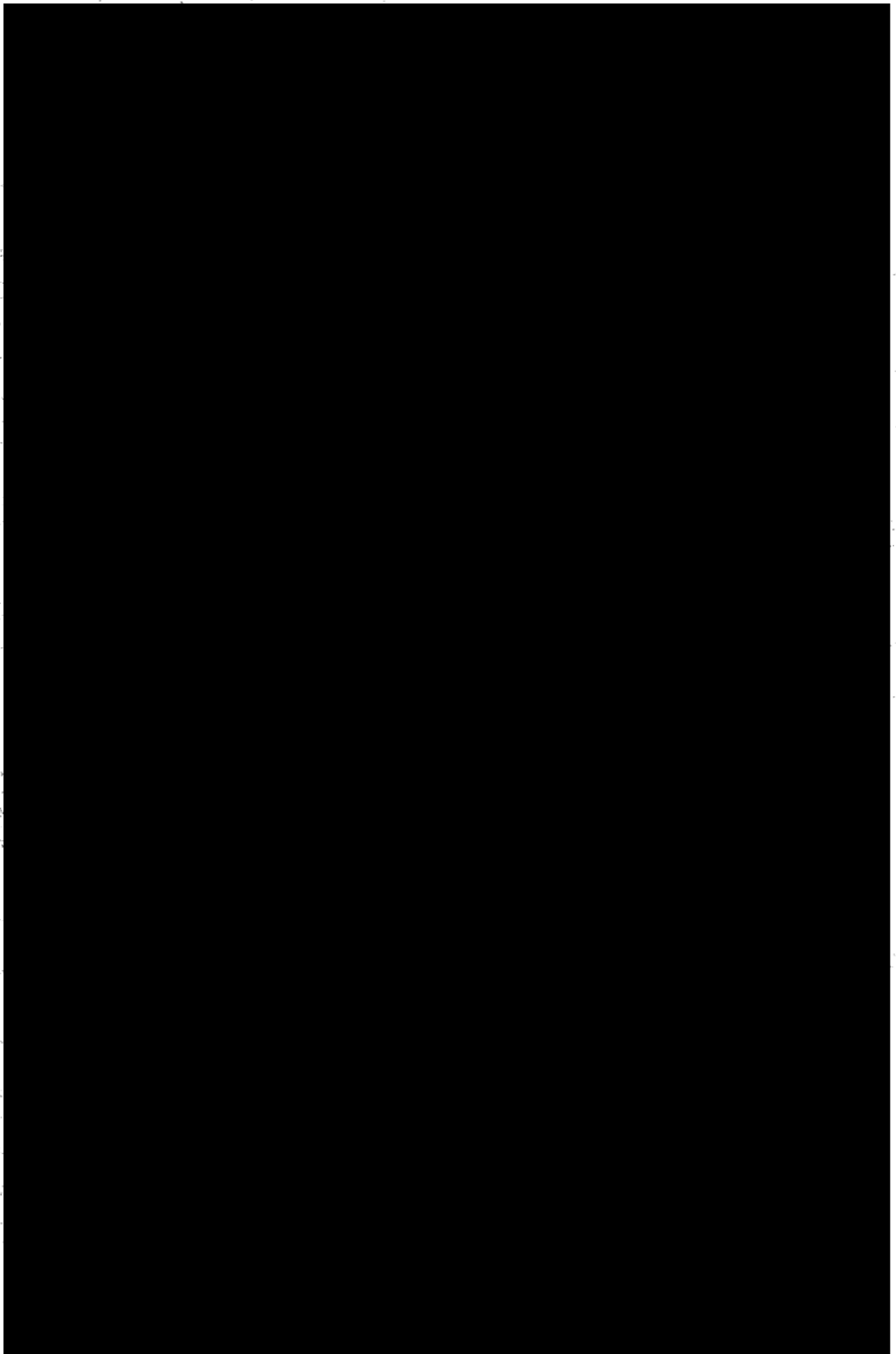




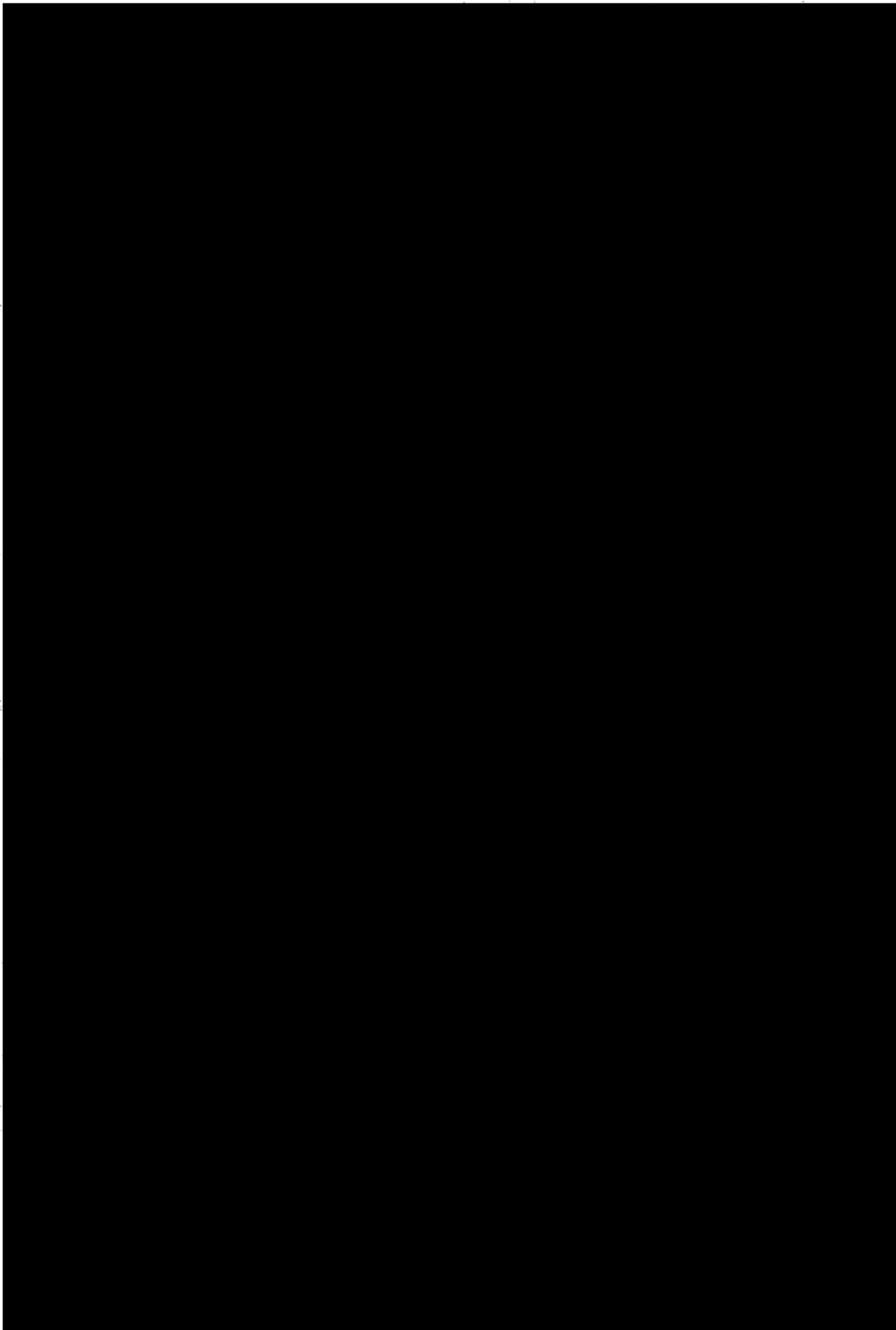


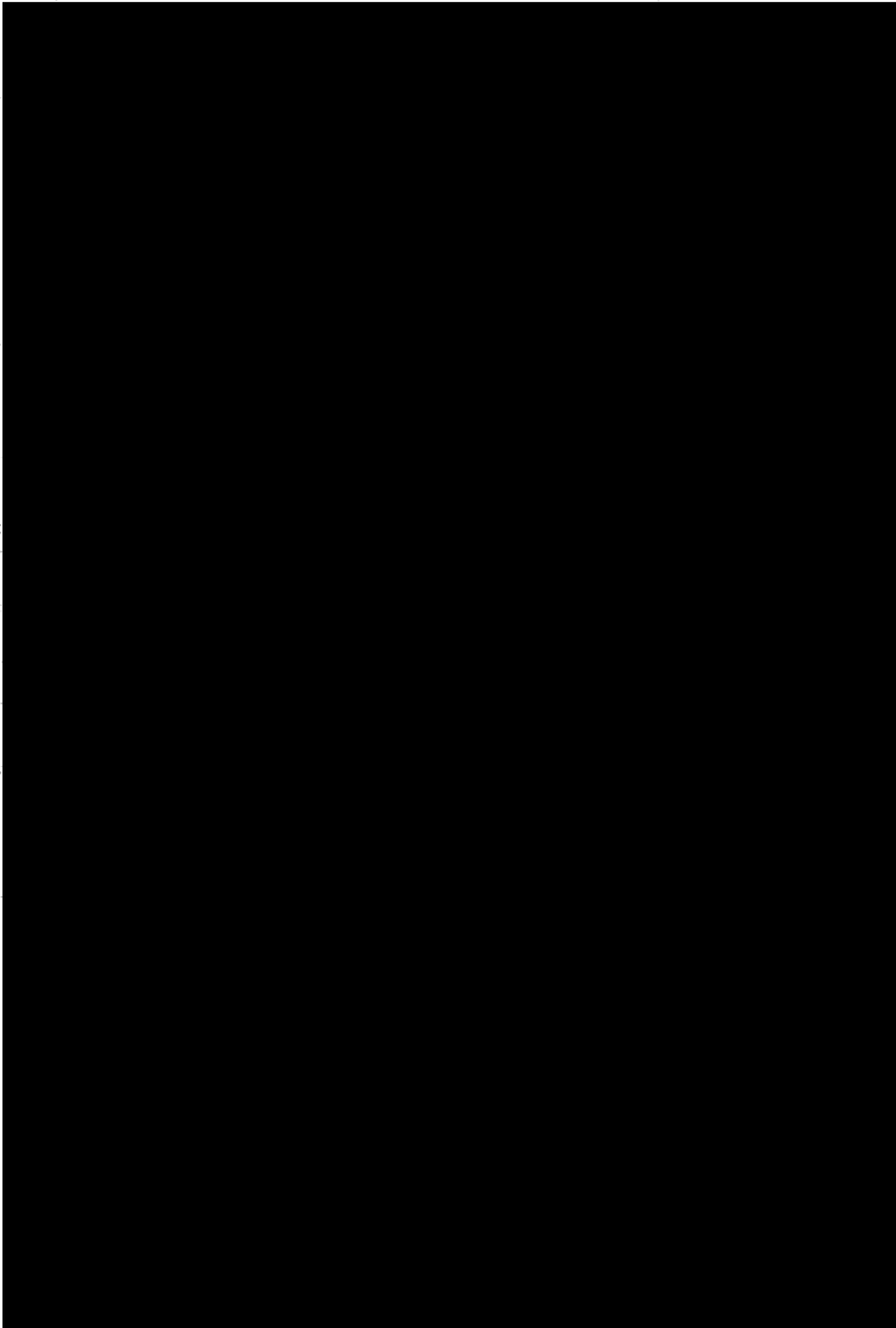


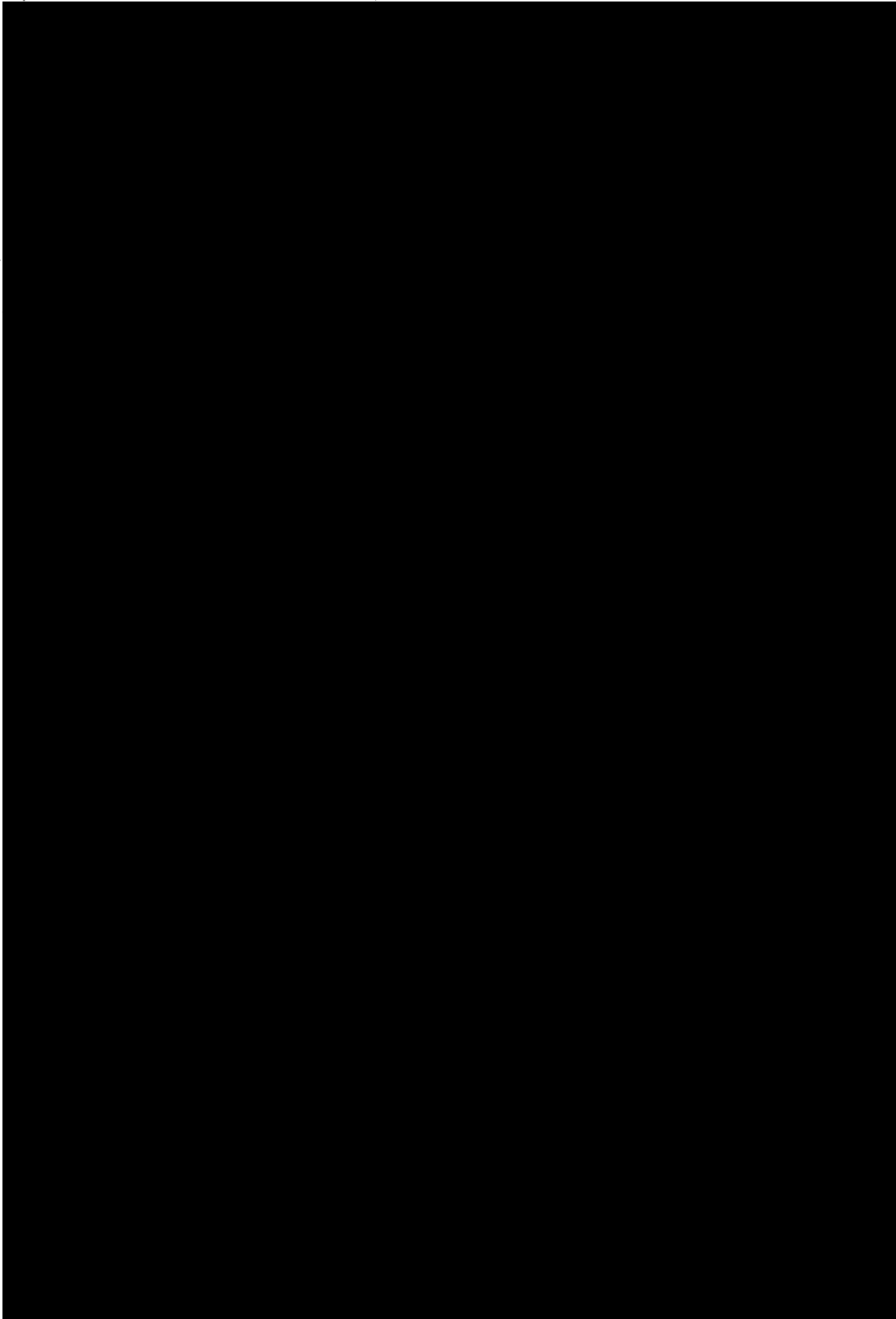












# **Exhibit L – Caesars Entertainment, Inc. Bylaws**

**CAESARS ENTERTAINMENT, INC.**

**BYLAWS**

ARTICLE I - STOCKHOLDERS

Section 1. Annual Meeting.

(1) An annual meeting of stockholders, for the election of directors to succeed those whose terms expire and for the transaction of such other business as may properly come before the meeting, shall be held at such place, on such date, and at such time as the Board of Directors shall fix.

(2) At a meeting of the stockholders, only such business shall be conducted as shall have been properly brought before the meeting. To be properly brought before a meeting, business must be (a) specified in the notice of meeting (or any supplement thereto) given by or at the direction of the Chairman of the Board, the Executive Chairman (if any), the Chief Executive Officer, the President or the Board of Directors, (b) otherwise properly brought before the meeting by or at the direction of the Board of Directors, or (c) otherwise properly brought before the meeting by a stockholder. In addition to any other applicable requirements, for business to be properly brought before a meeting by a stockholder, the stockholder must have given timely notice thereof in writing to the Secretary of the Corporation. To be timely, a stockholder's notice must be delivered to or mailed and received at the principal executive offices of the Corporation not less than forty-five (45) days nor more than seventy-five (75) days prior to the anniversary of the date on which the Corporation first mailed its proxy materials for the previous year's annual meeting of stockholders (or the date on which the Corporation mails its proxy materials for the current year if during the prior year the Corporation did not hold an annual meeting or if the date of the annual meeting was changed more than thirty (30) days from the prior year). A stockholder's notice to the Secretary shall set forth as to each matter the stockholder proposes to bring before the meeting (a) a brief description of the business desired to be brought before the annual meeting and the reasons for conducting such business at the meeting, (b) the name and address, as they appear on the Corporation's books, of the stockholder proposing such business, (c) the class and number of shares of the Corporation which are beneficially owned by the stockholder, and (d) any material interest of the stockholder in such business. Notwithstanding anything in these Bylaws to the contrary, no business shall be conducted at a meeting except in accordance with the procedures set forth in this Section 1; provided, however, that nothing in this Section 1 shall be deemed to preclude discussion by any stockholder of any business properly brought before the meeting in accordance with said procedure. The chairman of the meeting shall, if the facts warrant, determine and declare to the meeting that business was not properly brought before the meeting in accordance with the provisions of this Section 1, and if he or she should so determine, he or she shall so declare to the meeting. Any such business not properly brought before the meeting shall not be transacted. Nothing in this Section 1 shall affect the right of a stockholder to request inclusion of a proposal in the Corporation's proxy statement to the extent that such right is provided by an applicable rule of the Securities and Exchange Commission ("SEC").

(3) Nomination of candidates for election as directors of the Corporation at any annual meeting or other meeting of stockholders called for the election of directors, in whole or in part (an "Election Meeting"), may be made by the Board of Directors or by any stockholder entitled to vote at such Election Meeting, in accordance with the following procedures:

(i) Nominations made by the Board of Directors shall be made at a meeting of the Board of Directors or by written consent of the directors in lieu of a meeting prior to the date of the Election Meeting. At the request of the Secretary of the Corporation, each proposed nominee shall provide the Corporation with such information concerning himself or herself as is required, under the rules of the SEC, to be included in the Corporation's proxy statement soliciting proxies for his or her election as a director.

(ii) Not less than sixty (60) days prior to the date of the Election Meeting, any stockholder who intends to make a nomination at the Election Meeting shall deliver a notice to the Secretary of the Corporation setting forth (a) the name, age, business address and the residence address of each nominee proposed in such notice, (b) the principal occupation or employment of such nominee, (c) the number of shares of capital stock of the Corporation which are beneficially owned by each such nominee, and (d) such other information concerning each such nominee as would be required, under the rules of the SEC, in a proxy statement soliciting proxies for the election of such nominees. Such notice shall include a signed consent of each such nominee to serve as a director of the Corporation, if elected.

(iii) In the event that a person is validly designated as a nominee in accordance with this Section 1(3) and shall thereafter become unable or unwilling to stand for election to the Board of Directors, the Board of Directors or the stockholder who proposed such nominee, as the case may be, may designate a substitute nominee; provided, however, that if the date of the Election Meeting in question has been publicly disclosed prior to the requested substitution, such substitution may not, without the consent of the Board of Directors, be made unless it can be made in accordance with applicable requirements of the SEC without any resulting delay in the scheduled Election Meeting, unless such substitution is required by the NRS, SEC regulations or other laws, rules or regulations applicable to the Corporation.

(iv) If the chairman of the Election Meeting determines that a nomination was not made in accordance with the foregoing procedures, such nomination shall be void.

(4) A person shall not be eligible for election or re-election as a director at an annual meeting unless (i) the person is nominated by a Record Stockholder in accordance with Section 1(2)(c) or (ii) the person is nominated by or at the direction of the Board of Directors. Only such business shall be conducted at an annual meeting of stockholders as shall have been brought before the meeting in accordance with the procedures set forth in this section. The chairman of the meeting shall have the power and the duty to determine whether a nomination or any business proposed to be brought before the meeting has been made in accordance with the procedures set forth in these Bylaws and, if any proposed nomination or business is not in compliance with these Bylaws, to declare that such defectively proposed business or nomination shall not be presented for stockholder action at the meeting and shall be disregarded.

(5) For purposes of these Bylaws, “public announcement” shall mean disclosure in a press release reported by the Dow Jones News Service, Associated Press or a comparable national news service or in a document publicly filed by the Corporation with the Securities and Exchange Commission pursuant to Section 13, 14 or 15(d) of the Exchange Act.

(6) Notwithstanding the foregoing provisions of this Section 1, a stockholder shall also comply with all applicable requirements of the Exchange Act and the rules and regulations thereunder with respect to matters set forth in this Section 1. Nothing in this Section 1 shall be deemed to affect any rights of stockholders to request inclusion of proposals in the Corporation’s proxy statement pursuant to Rule 14a-8 under the Exchange Act.

## Section 2. Special Meetings.

(1) Special meetings of the stockholders, other than those required by statute, may be called at any time by the President or Board of Directors acting pursuant to a resolution adopted by a majority of the Whole Board and shall be called by the President at the request in writing of stockholders owning not less than ten percent (10%) of the entire capital stock of the Corporation issued and outstanding and entitled to vote. Any special meeting called at the request of the stockholders pursuant to the preceding sentence shall be held on a date no later than 60 days following the Corporation’s receipt of the stockholders’ written request for such a meeting. For purposes of these Bylaws, the term “Whole Board” shall mean the total number of authorized directors whether or not there exist any vacancies in previously authorized directorships. The Board of Directors may postpone or reschedule any previously scheduled special meeting, other than a special meeting called at the request of the stockholders in accordance with this clause (1).

(2) Only such business shall be conducted at a special meeting of stockholders as shall have been brought before the meeting by or at the direction of the Chairman of the Board, the Chief Executive Officer, the Board of Directors or the stockholders. The notice of such special meeting shall include the purpose for which the meeting is called. Nominations of persons for election to the Board of Directors may be made at a special meeting of stockholders at which directors are to be elected (a) by or at the direction of the Board of Directors or (b) by any stockholder of record at the time of giving of notice provided for in this paragraph, who shall be entitled to vote at the meeting and who delivers a written notice to the Secretary setting forth the information set forth in Section 1(4)(a) and 1(4)(c) of this Article I. Nominations by stockholders of persons for election to the Board of Directors may be made at such a special meeting of stockholders only if such stockholder of record’s notice required by the preceding sentence shall be received by the Secretary at the principal executive offices of the Corporation not later than the close of business on the later of the 60th day prior to such special meeting or the 10th day following the day on which public announcement is first made of the date of the special meeting and of the nominees proposed by the Board of Directors to be elected at such meeting. In no event shall an adjournment, or postponement of a special meeting for which notice has been given, commence a new time period for the giving of a stockholder of record’s notice. A person shall not be eligible for election or reelection as a director at a special meeting unless the person is nominated (i) by or at the direction of the Board of Directors or (ii) by a stockholder of record in accordance with the notice procedures set forth in this Article I.

(3) Notwithstanding the foregoing provisions of this Section 2, a stockholder shall also comply with all applicable requirements of the Exchange Act and the rules and regulations thereunder with respect to matters set forth in this Section 2. Nothing in this Section 2 shall be deemed to affect any rights of stockholders to request inclusion of proposals in the Corporation's proxy statement pursuant to Rule 14a-8 under the Exchange Act.

Section 3. Notice of Meetings.

Written notice of the annual and each special meeting of stockholders shall be signed by the Chairman of the Board, the Executive Chairman (if any), the Chief Executive Officer, the President or the Secretary of the Corporation. Notice of the place, if any, date, and time of all meetings of the stockholders, the means of remote communications, if any, by which stockholders and proxyholders may be deemed to be present in person and vote at such meeting, and the record date for determining the stockholders entitled to vote at the meeting, if such date is different from the record date for determining stockholders entitled to notice of the meeting, shall be given, not less than 10 nor more than 60 days before the date on which the meeting is to be held, to each stockholder entitled to vote at such meeting as of the record date for determining the stockholders entitled to notice of the meeting, except as otherwise provided herein or required by law (meaning, here and hereinafter, as required from time to time by the Delaware General Corporation Law ("DGCL") or the Certificate of Incorporation of the Corporation).

When a meeting is adjourned to another time or place, notice need not be given of the adjourned meeting if the time and place, if any, thereof, and the means of remote communications, if any, by which stockholders and proxyholders may be deemed to be present in person and vote at such adjourned meeting are announced at the meeting at which the adjournment is taken; provided, however, that if the date of any adjourned meeting is more than 30 days after the date for which the meeting was originally noticed, notice of the place, if any, date, and time of the adjourned meeting and the means of remote communications, if any, by which stockholders and proxyholders may be deemed to be present in person and vote at such adjourned meeting, shall be given to each stockholder in conformity herewith. If after the adjournment a new record date for stockholders entitled to vote is fixed for the adjourned meeting, the Board of Directors shall fix a new record date for notice of such adjourned meeting, which record date shall not precede the date upon which the resolution fixing the record date is adopted by the Board of Directors and, except as otherwise required by law, shall not be more than 60 nor less than 10 days before the date of such adjourned meeting, and shall give notice of the adjourned meeting to each stockholder of record entitled to vote at such adjourned meeting as of the record date fixed for notice of such adjourned meeting. At any adjourned meeting, any business may be transacted which might have been transacted at the original meeting.

Section 4. Quorum.

At any meeting of the stockholders, the holders of a majority of the voting power of all of the shares of the stock entitled to vote at the meeting, present in person or by proxy, shall constitute a quorum for all purposes, unless or except to the extent that the presence of a larger number may be required by law or by the rules of any stock exchange upon which the Corporation's securities are listed. Where a separate vote by a class or classes or series is required, a majority of the voting power of the shares of such class or classes or series present in person or



represented by proxy shall constitute a quorum entitled to take action with respect to that vote on that matter.

If a quorum shall fail to attend any meeting, the chairman of the meeting may adjourn the meeting to another place, if any, date, or time.

Section 5. Organization.

Such person as the Board of Directors may have designated or, in the absence of such a person, the Chairman of the Board or, in his or her absence, the Chief Executive Officer or the President of the Corporation or, in his or her absence, such person as may be chosen by the holders of a majority of the voting power of the shares entitled to vote who are present, in person or by proxy, shall call to order any meeting of the stockholders and act as chairman of the meeting. In the absence of the Secretary of the Corporation, the secretary of the meeting shall be such person as the chairman of the meeting appoints.

Section 6. Conduct of Business.

The chairman of any meeting of stockholders shall determine the order of business and the procedure at the meeting, including such regulation of the manner of voting and the conduct of discussion as seem to him or her in order. The chairman shall have the power to adjourn the meeting to another place, if any, date and time. The date and time of the opening and closing of the polls for each matter upon which the stockholders will vote at the meeting shall be announced at the meeting.

Section 7. Proxies and Voting.

At any meeting of the stockholders, every stockholder entitled to vote may vote in person or by proxy authorized by an instrument in writing or by a transmission permitted by law filed in accordance with the procedure established for the meeting. Any copy, facsimile telecommunication or other reliable reproduction of the writing or transmission created pursuant to this paragraph may be substituted or used in lieu of the original writing or transmission for any and all purposes for which the original writing or transmission could be used, provided that such copy, facsimile telecommunication or other reproduction shall be a complete reproduction of the entire original writing or transmission.

The Corporation may, and to the extent required by law, shall, in advance of any meeting of stockholders, appoint one or more inspectors to act at the meeting and make a written report thereof. The Corporation may designate one or more alternate inspectors to replace any inspector who fails to act. If no inspector or alternate is able to act at a meeting of stockholders, the person presiding at the meeting may, and to the extent required by law, shall, appoint one or more inspectors to act at the meeting. Each inspector, before entering upon the discharge of his or her duties, shall take and sign an oath faithfully to execute the duties of inspector with strict impartiality and according to the best of his or her ability. Every vote taken by ballots shall be counted by a duly appointed inspector or inspectors.

All elections shall be determined by a plurality of the votes cast, and except as otherwise required by law or the rules of any stock exchange upon which the Corporation's

securities are listed, all other matters shall be determined by a majority of the votes cast affirmatively or negatively.

Section 8. Consent of Stockholders. Any action required or permitted by the DGCL to be taken at any meeting of the stockholders may be taken without a meeting, without prior notice, and without a vote if the action is evidenced by one or more written consents, which may be signed in counterparts, describing the action taken, signed by the holders of outstanding stock having not less than the minimum number of votes that would be necessary to authorize or take such action at a meeting at which all shares entitled to vote thereon were present and voted. Any such action by written consent shall be effective upon the date specified in the consent so long as written consents signed by a sufficient number of stockholders are delivered to the Corporation in the manner specified above within 60 days of the earliest dated consent. Prompt notice of the taking of the corporate action without a meeting by less than unanimous written consent shall be given to those stockholders who have not consented in writing. A written consent of the stockholders given in accordance with this Section 8 has the same force and effect as a vote of such stockholders and may be stated as such in any document. The record date for determining stockholders entitled to take action without a meeting is set forth in Section 3 of Article V.

Section 9. Stock List.

The officer who has charge of the stock ledger of the Corporation shall, at least 10 days before every meeting of stockholders, prepare and make a complete list of stockholders entitled to vote at any meeting of stockholders, provided, however, if the record date for determining the stockholders entitled to vote is less than 10 days before the meeting date, the list shall reflect the stockholders entitled to vote as of the 10th day before the meeting date, arranged in alphabetical order and showing the address of each such stockholder and the number of shares registered in his or her name. Such list shall be open to the examination of any stockholder for a period of at least 10 days prior to the meeting in the manner provided by law.

A stock list shall also be open to the examination of any stockholder during the whole time of the meeting as provided by law. This list shall presumptively determine (a) the identity of the stockholders entitled to examine such stock list and to vote at the meeting and (b) the number of shares held by each of them.

ARTICLE II - BOARD OF DIRECTORS

Section 1. Number, Election and Term of Directors.

The number of directors which shall constitute the whole Board of Directors shall be not less than five (5) and not more than eleven (11). Within the limits above specified, the number of the directors of the Corporation shall be determined by resolution adopted by the Board of Directors. All directors shall be elected annually. Except as provided in Section 2 of this Article II, directors shall be elected at the annual meeting of stockholders by a plurality of the votes cast at the applicable election and each director shall hold office until his or her successor is elected and qualified. The composition of the Board of Directors and the committees thereof shall comply with applicable requirements of the DGCL, the SEC and NASDAQ Stock Market, or such other organization, association or entity with which any class of the Corporation's securities are listed.

Directors need not be residents of Delaware or stockholders of the Corporation. The Board of Directors shall designate one director as the Chairman of the Board (who may also be designated as Executive Chairman if serving as an employee of the Corporation), who shall preside at all meetings of the Board of Directors and of the stockholders of the Corporation. In the Chairman of the Board's absence, the duties as Chairman of the Board shall be attended to by any vice chairman of the Board of Directors, or if there is no vice chairman, or such vice chairman is absent, then by the President.

Section 2. Newly Created Directorships and Vacancies.

Newly created directorships resulting from any increase in the authorized number of directors or any vacancies in the Board of Directors resulting from death, resignation, disqualification, removal from office or other cause shall, unless otherwise required by law or by resolution of the Board of Directors, be filled only by (i) the holders of a majority of the voting power of all then outstanding capital stock of the Corporation then entitled to vote generally in the election of directors at a meeting of stockholders called for such purpose or (ii) the unanimous written consent or vote of a majority of the directors then in office, though less than a quorum, and directors so chosen shall serve for a term expiring at the next annual meeting of stockholders, with each director to hold office until his or her successor shall have been duly elected and qualified. No decrease in the authorized number of directors shall shorten the term of any incumbent director.

Section 3. Regular Meetings.

Regular meetings of the Board of Directors shall be held at such place or places, on such date or dates, and at such time or times as shall have been established by the Board of Directors and publicized among all directors. A notice of each regular meeting shall not be required.

Section 4. Special Meetings.

Special meetings of the Board of Directors may be called by the Chairman of the Board, the Chief Executive Officer, or by the President, and shall be called by the Secretary on the written request of any two directors and shall be held at such place, on such date, and at such time as they or he or she shall fix. Notice of the place, date, and time of each such special meeting shall be given to each director by whom it is not waived by mailing written notice not less than five days before the meeting or by telephone or by telegraphing or telexing or by facsimile or electronic transmission of the same not less than 48 hours before the meeting. Unless otherwise indicated in the notice thereof, any and all business may be transacted at a special meeting.

Section 5. Quorum.

A majority of the Whole Board shall constitute a quorum for all purposes at any meeting of the Board of Directors. If a quorum shall fail to attend any meeting, a majority of those present may adjourn the meeting to another place, date, or time, without further notice or waiver thereof.

Section 6. Participation in Meetings By Conference Telephone.

Members of the Board of Directors, or of any committee thereof, may participate in a meeting of such Board of Directors or committee by means of conference telephone or other communications equipment by means of which all persons participating in the meeting can hear each other and such participation shall constitute presence in person at such meeting.

Section 7. Conduct of Business.

At any meeting of the Board of Directors, business shall be transacted in such order and manner as the Board of Directors may from time to time determine, and, except as otherwise expressly required by law, all matters shall be determined by the affirmative vote of a majority of the directors present at any meeting at which a quorum is present. Action may be taken by the Board of Directors without a meeting if all members thereof consent thereto in writing or by electronic transmission, and the writing or writings or electronic transmission or transmissions are filed with the minutes of proceedings of the Board of Directors. Such filing shall be in paper form if the minutes are maintained in paper form and shall be in electronic form if the minutes are maintained in electronic form.

Section 8. Compensation of Directors.

Unless otherwise restricted by the Certificate of Incorporation, the Board of Directors shall have the authority to fix the compensation of the directors. The directors may be paid their expenses, if any, of attendance at each meeting of the Board of Directors and may be paid a fixed sum for attendance at each meeting of the Board of Directors or paid a stated salary or paid other compensation as director. No such payment shall preclude any director from serving the Corporation in any other capacity and receiving compensation therefor. Members of special or standing committees may be allowed compensation for attending committee meetings.

Section 9. Action Without Meeting.

Unless otherwise restricted by the Certificate of Incorporation or these Bylaws, any action required or permitted to be taken at any meeting of the Board of Directors, or of any committee thereof as provided in Article II, may be taken without a meeting, if a written consent thereto is signed by all (or such lesser proportion as may be permitted by the DGCL) of the members of the Board of Directors or of such committee, as the case may be.

ARTICLE III - COMMITTEES

Section 1. Committees of the Board of Directors.

The Board of Directors may from time to time designate committees of the Board of Directors, with such lawfully delegable powers and duties as it thereby confers, to serve at the pleasure of the Board of Directors and shall, for those committees and any others provided for herein, elect a director or directors to serve as the member or members, designating, if it desires, other directors as alternate members who may replace any absent or disqualified member at any meeting of the committee. In the absence or disqualification of any member of any committee and any alternate member in his or her place, the member or members of the committee present at the

meeting and not disqualified from voting, whether or not he or she or they constitute a quorum, may by unanimous vote appoint another member of the Board of Directors to act at the meeting in the place of the absent or disqualified member.

Section 2.      Audit Committee.

An audit committee of the Board of Directors (the “Audit Committee”) shall consist of at least three directors designated annually by the Board of Directors at its first regular meeting held pursuant to Section 3 of Article II after the annual meeting of stockholders or as soon thereafter as conveniently possible. The Audit Committee shall consist solely of directors who are “independent” as determined under the corporate governance standards of the NASDAQ Stock Market applicable to the Corporation and satisfy the requirements of SEC Rule 10A-3. At least one of the members of the Audit Committee shall be determined by the Board of Directors to be an “audit committee financial expert” as defined in SEC Rule 407(d)(5). Members of the Audit Committee shall review and supervise the financial controls of the Corporation, make recommendations to the Board of Directors regarding the Corporation’s auditors, review the books and accounts of the Corporation, meet with the officers of the Corporation regarding the Corporation’s financial controls, act upon recommendations of the auditors and take such further action as the Audit Committee deems necessary to complete an audit of the books and accounts of the Corporation.

Section 3.      Compensation Committee.

The compensation committee of the Board of Directors (the “Compensation Committee”) shall consist of two or more directors to be designated annually by the Board of Directors at its first regular meeting held pursuant to Section 3 of Article II after the annual meeting of stockholders or as soon thereafter as conveniently possible. Each member of the Compensation Committee shall be “independent” as determined under the corporate governance standards of the NASDAQ Stock Market applicable to the Corporation. The Compensation Committee shall review with management cash and other compensation policies for employees, shall determine the compensation of the Chief Executive Officer and each of the other executive officers of the Corporation and shall make recommendations to the Chief Executive Officer regarding the compensation to be established for all other officers of the Corporation. In addition, the Compensation Committee shall have full power and authority to administer the Corporation’s stock plans and, within the terms of the respective stock plans, determine the terms and conditions of issuances thereunder.

Section 4.      Directors’ Nominating Committee.

A directors’ nominating committee of the Board of Directors (the “Nominating Committee”) shall be designated annually by the Board of Directors at its first regular meeting held pursuant to Section 3 of Article II after the annual meeting of stockholders or as soon thereafter as conveniently possible. The Nominating Committee shall consist solely of directors who are “independent” as determined under the corporate governance standards of the NASDAQ Stock Market applicable to the Corporation. The members of the Nominating Committees shall evaluate and select or recommend to the Board of Directors candidates to fill positions on the Board of Directors.

Section 5. Conduct of Business.

Each committee may determine the procedural rules for meeting and conducting its business and shall act in accordance therewith, except as otherwise provided herein or required by law. Adequate provision shall be made for notice to members of all meetings; a majority of the members shall constitute a quorum unless the committee shall consist of one or two members, in which event one member shall constitute a quorum; and all matters shall be determined by a majority vote of the members present. Action may be taken by any committee without a meeting if all members thereof consent thereto in writing or by electronic transmission, and the writing or writings or electronic transmission or transmissions are filed with the minutes of the proceedings of such committee. Such filing shall be in paper form if the minutes are maintained in paper form and shall be in electronic form if the minutes are maintained in electronic form. The Board of Directors may designate one (1) or more appropriate directors as alternate members of any committee, who may replace any absent or disqualified member at any meeting of such committee. In the absence or disqualification of any members of such committee or committees, the member or members thereof present at any meeting and not disqualified from voting, whether or not he, she or they constitute a quorum, may unanimously appoint another appropriate member of the Board of Directors to act at the meeting in the place of any absent or disqualified member.

Section 6. Minutes.

Each committee of directors shall keep regular minutes of its proceedings and report the same to the Board of Directors when required. The Corporation's Secretary, any Assistant Secretary or any other designated person shall (a) serve as the Secretary of the special or standing committees of the Board of Directors of the Corporation, (b) keep regular minutes of standing or special committee proceedings, (c) make available to the Board of Directors, as required, copies of all resolutions adopted or minutes or reports of other actions recommended or taken by any such standing or special committee and (d) otherwise as requested keep the members of the Board of Directors apprised of the actions taken by such standing or special committees.

ARTICLE IV - OFFICERS

Section 1. Generally.

The officers of the Corporation shall consist of a Chief Executive Officer, a President, one or more Vice Presidents, a Secretary, a Treasurer; may include an Executive Chairman, as elected or appointed by the Board of Directors; and may further include, without limitation, such other officers and agents, including, without limitation, a Chief Financial Officer, one or more Vice Presidents (anyone or more of which may be designated Senior Executive Vice President, Executive Vice President or Senior Vice President), Assistant Vice Presidents, Assistant Secretaries and Assistant Treasurers, as the Board of Directors, Chairman of the Board, Chief Executive Officer or President deem necessary and elect or appoint. Officers shall be elected by the Board of Directors, which shall consider that subject at its first meeting after every annual meeting of stockholders. Each officer shall hold office until his or her successor is elected and qualified or until his or her earlier resignation or removal. Any number of offices may be held by the same person. All officers of the Corporation shall hold their offices for such terms and shall exercise such powers and perform such duties as prescribed by these bylaws, the Board of

Directors, Chairman of the Board, Chief Executive Officer or President, as applicable. Any two or more offices may be held by the same person. No officer shall execute, acknowledge, verify or countersign any instrument on behalf of the Corporation in more than one capacity, if such instrument is required by law, by these bylaws or by any act of the Corporation to be executed, acknowledged, verified or countersigned by two or more officers. The salaries of officers elected by the Board of Directors shall be fixed from time to time by the Board of Directors or by such officers as may be designated by resolution of the Board of Directors.

Section 2. Executive Chairman.

The Board of Directors may appoint an Executive Chairman if the Chairman of the Board is an employee of the Corporation. The Executive Chairman shall, in general, perform such duties as may be prescribed by the Board of Directors. He or she shall, in coordination with the Chief Executive Officer, formulate and submit to the Board of Directors matters of general policy for the Corporation and shall perform such other duties as usually appertain to the office or as may be prescribed by the Board of Directors. He or she may or sign with the Chief Executive Officer, the President or any other officer of the Corporation thereunto authorized by the Board of Directors certificates for shares of capital stock of the Corporation, the issuance of which shall have been authorized by resolution of the Board of Directors, and any deeds, bonds, mortgages, contracts, checks, notes, drafts or other instruments which the Board of Directors has authorized to be executed, except in cases where the signing and execution thereof has been expressly delegated by these bylaws or by the Board of Directors to some other officer or agent of the Corporation, or shall be required by law to be otherwise executed.

Section 3. Chief Executive Officer.

The Chief Executive Officer shall, in general, perform such duties as usually pertain to the position of chief executive officer and such other duties as may be prescribed by the Board of Directors. He or she shall, in coordination with the Executive Chairman (if any), formulate and submit to the Board of Directors matters of general policy for the Corporation and shall perform such other duties as usually appertain to the office or as may be prescribed by the Board of Directors. He or she may sign with the President or any other officer of the Corporation thereunto authorized by the Board of Directors certificates for shares of the Corporation, the issuance of which shall have been authorized by resolution of the Board of Directors, and any deeds or bonds, which the Board of Directors has authorized to be executed, except in cases where the signing and execution thereof has been expressly delegated or reserved by these bylaws or by the Board of Directors or to some other officer or agent of the Corporation, or shall be required by law to be otherwise executed.

Section 4. President.

The President, subject to the control of the Board of Directors, the Executive Chairman (if any) and the Chief Executive Officer, shall in general supervise and control the business and affairs of the Corporation. The President shall keep the Board of Directors, the Chairman of the Board and the Chief Executive Officer fully informed as they or any of them shall request and shall consult them concerning the business of the Corporation. He or she may sign with the Executive Chairman (if any), the Chief Executive Officer or any other officer of the

Corporation thereunto authorized by the Board of Directors, certificates for shares of capital stock of the Corporation, the issuance of which shall have been authorized by resolution of the Board of Directors, and any deeds, bonds, mortgages, contracts, checks, notes, drafts or other instruments which the Board of Directors has authorized to be executed, except in cases where the signing and execution thereof has been expressly delegated by these bylaws or by the Board of Directors to some other officer or agent of the Corporation, or shall be required by law to be otherwise executed. In general, he or she shall perform all other duties normally incident to the office of the President, except any duties expressly delegated to other persons by these bylaws, the Board of Directors, and such other duties as may be prescribed by the stockholders, the Board of Directors, the Chairman of the Board or the Chief Executive Officer, from time to time.

Section 5. Vice President.

In the absence of the President, or in the event of his or her inability or refusal to act, the Senior Executive Vice President (or in the event there shall be more than one Vice President designated Senior Executive Vice President, any Senior Executive Vice President designated by the Board of Directors), or in the event of the Senior Executive Vice President's inability or refusal to act, the Executive Vice President (or in the event there shall be more than one such officer, any such officer designated by the Board of Directors) shall perform the duties and exercise the powers of the President. Any Vice President authorized by resolution of the Board of Directors to do so, may sign with any other officer of the Corporation thereunto authorized by the Board of Directors, certificates for shares of capital stock of the Corporation, the issuance of which shall have been authorized by resolution of the Board of Directors. The Vice Presidents shall perform such other duties as from time to time may be assigned to them by the Board of Directors, the Chairman of the Board, the Chief Executive Officer or the President.

Section 6. Treasurer.

The Treasurer shall (a) have charge and custody of and be responsible for all funds and securities of the Corporation; receive and give receipts for moneys due and payable to the Corporation from any source whatsoever and deposit all such moneys in the name of the Corporation in such banks, trust companies or other depositories; (b) prepare, or cause to be prepared, for submission at each regular meeting of the Board of Directors, at each annual meeting of stockholders, and at such other times as may be required by the Board of Directors, the Chairman of the Board, the Chief Executive Officer or the President, a statement of financial condition of the Corporation in such detail as may be required; and (c) in general, perform all the duties incident to the office of Treasurer and such other duties as from time to time may be assigned to him or her by the Chairman of the Board, the Chief Executive Officer, the President or the Board of Directors. If required by the Board of Directors, the Treasurer shall give a bond for the faithful discharge of his or her duties in such sum and with such surety or sureties as the Board of Directors shall determine.

Section 7. Secretary.

The Secretary shall (a) keep the minutes of the meetings of the stockholders, the Board of Directors and committees of directors; (b) see that all notices are duly given in accordance with the provisions of these bylaws and as required by law; (c) be custodian of the corporate



records and of the seal of the Corporation, and see that the seal of the Corporation or a facsimile thereof is affixed to all certificates for shares prior to the issuance thereof and to all documents, the execution of which on behalf of the Corporation under its seal is duly authorized in accordance with the provisions of these bylaws; (d) keep or cause to be kept a register of the post office address of each stockholder which shall be furnished by such stockholder; (e) have general charge of other stock transfer books of the Corporation; and (f) in general, perform all duties normally incident to the office of the Secretary and such other duties as from time to time may be assigned to him or her by the Chairman of the Board, the Chief Executive Officer, the President or the Board of Directors.

Section 8. Assistant Secretary or Treasurer.

The Assistant Secretaries and Assistant Treasurers shall, in general, perform such duties as shall be assigned to them by the Secretary or the Treasurer, respectively, or by the Chairman of the Board, the Chief Executive Officer, the President or the Board of Directors. The Assistant Secretaries or Assistant Treasurers shall, in the absence of the Secretary or Treasurer, respectively, perform all functions and duties which such absent officers may delegate, but such delegation shall not relieve the absent officer from the responsibilities and liabilities of his or her office. The Assistant Treasurers shall respectively, if required by the Board of Directors, give bonds for the faithful discharge of their duties in such sums and with such sureties as the Board of Directors shall determine.

Section 9. Chief Financial Officer.

The Chief Financial Officer shall, in general, perform such duties as usually pertain to the position of chief financial officer and such duties as may be prescribed by the Board of Directors.

Section 10. Delegation of Authority.

The Board of Directors may from time to time delegate the powers or duties of any officer to any other officers or agents, notwithstanding any provision hereof.

Section 11. Removal.

Any officer of the Corporation may be removed at any time, with or without cause, by the Board of Directors.

Section 12. Action with Respect to Securities of Other Corporations.

Unless otherwise directed by the Board of Directors, the President or any officer of the Corporation authorized by the President shall have power to vote and otherwise act on behalf of the Corporation, in person or by proxy, at any meeting of stockholders of or with respect to any action of stockholders of any other Corporation in which this Corporation may hold securities and otherwise to exercise any and all rights and powers which this Corporation may possess by reason of its ownership of securities in such other Corporation.

## ARTICLE V - STOCK

### Section 1.      Certificates of Stock.

Each holder of stock represented by certificates shall be entitled to a certificate signed by, or in the name of the Corporation by, the President or a Vice President, and by the Secretary or an Assistant Secretary, or the Treasurer or an Assistant Treasurer, certifying the number of shares owned by him or her. Any or all of the signatures on the certificate may be by facsimile.

### Section 2.      Transfers of Stock.

Transfers of stock shall be made only upon the transfer books of the Corporation kept at an office of the Corporation or by transfer agents designated to transfer shares of the stock of the Corporation. Except where a certificate is issued in accordance with Section 4 of Article V of these Bylaws, an outstanding certificate for the number of shares involved, if one has been issued, shall be surrendered for cancellation before a new certificate, if any, is issued therefor.

### Section 3.      Record Date.

In order that the Corporation may determine the stockholders entitled to notice of any meeting of stockholders or any adjournment thereof, the Board of Directors may, except as otherwise required by law, fix a record date, which record date shall not precede the date upon which the resolution fixing the record date is adopted by the Board of Directors, and which record date shall not be more than 60 nor less than 10 days before the date of such meeting. If the Board of Directors so fixes a date, such date shall also be the record date for determining the stockholders entitled to vote at such meeting unless the Board of Directors determines, at the time it fixes such record date, that a later date on or before the date of the meeting shall be the date for making such determination. If no record date is fixed by the Board of Directors, the record date for determining stockholders entitled to notice of and to vote at a meeting of stockholders shall be at the close of business on the day next preceding the day on which notice is given or, if notice is waived, at the close of business on the day next preceding the day on which the meeting is held. A determination of stockholders of record entitled to notice of or to vote at a meeting of stockholders shall apply to any adjournment of the meeting; provided, however, that the Board of Directors may fix a new record date for determination of stockholders entitled to vote at the adjourned meeting, and in such case shall also fix as the record date for stockholders entitled to notice of such adjourned meeting the same or an earlier date as that fixed for determination of stockholders entitled to vote in accordance with the foregoing provisions of this Section 3 at the adjourned meeting.

In order that the Corporation may determine the stockholders entitled to receive payment of any dividend or other distribution or allotment of any rights or the stockholders entitled to exercise any rights in respect of any change, conversion or exchange of stock, or for the purpose of any other lawful action, the Board of Directors may fix a record date, which record date shall not precede the date upon which the resolution fixing the record date is adopted, and which record date shall be not more than 60 days prior to such action. If no record date is fixed, the record date for determining stockholders for any such purpose shall be at the close of business on the day on which the Board of Directors adopts the resolution relating thereto.

Section 4. Lost, Stolen or Destroyed Certificates.

In the event of the loss, theft or destruction of any certificate of stock, another may be issued in its place pursuant to such regulations as the Board of Directors may establish concerning proof of such loss, theft or destruction and concerning the giving of a satisfactory bond or bonds of indemnity.

Section 5. Regulations.

The issue, transfer, conversion and registration of certificates of stock shall be governed by such other regulations as the Board of Directors may establish.

ARTICLE VI - NOTICES

Section 1. Notices.

If mailed, notice to stockholders shall be deemed given when deposited in the mail, postage prepaid, directed to the stockholder at such stockholder's address as it appears on the records of the Corporation. Without limiting the manner by which notice otherwise may be given effectively to stockholders, any notice to stockholders may be given by electronic transmission in the manner provided in Section 232 of the DGCL.

Section 2. Waivers.

A written waiver of any notice, signed by a stockholder or director, or waiver by electronic transmission by such person, whether given before or after the time of the event for which notice is to be given, shall be deemed equivalent to the notice required to be given to such person. Neither the business nor the purpose of any meeting need be specified in such a waiver. Attendance at any meeting shall constitute waiver of notice except attendance for the express purpose of objecting at the beginning of the meeting to the transaction of business because the meeting is not lawfully called or convened.

ARTICLE VII - MISCELLANEOUS

Section 1. Facsimile Signatures.

In addition to the provisions for use of facsimile signatures elsewhere specifically authorized in these Bylaws, facsimile signatures of any officer or officers of the Corporation may be used whenever and as authorized by the Board of Directors or a committee thereof.

Section 2. Corporate Seal.

The Board of Directors may provide a suitable seal, containing the name of the Corporation, which seal shall be in the charge of the Secretary. If and when so directed by the Board of Directors or a committee thereof, duplicates of the seal may be kept and used by the Treasurer or by an Assistant Secretary or Assistant Treasurer.

Section 3. Reliance upon Books, Reports and Records.

Each director, each member of any committee designated by the Board of Directors, and each officer of the Corporation shall, in the performance of his or her duties, be fully protected in relying in good faith upon the books of account or other records of the Corporation and upon such information, opinions, reports or statements presented to the Corporation by any of its officers or employees, or committees of the Board of Directors so designated, or by any other person as to matters which such director, committee member or officer reasonably believes are within such other person's professional or expert competence and who has been selected with reasonable care by or on behalf of the Corporation.

Section 4. Fiscal Year.

The fiscal year of the Corporation shall be as fixed by the Board of Directors.

Section 5. Time Periods.

In applying any provision of these Bylaws which requires that an act be done or not be done a specified number of days prior to an event or that an act be done during a period of a specified number of days prior to an event, calendar days shall be used, the day of the doing of the act shall be excluded, and the day of the event shall be included.

ARTICLE VIII – SHAREHOLDER RIGHTS PLAN

Any Rights Plan adopted by the Board of Directors shall have a triggering "Acquiring Person" beneficial ownership threshold of 25% or higher. If the Board of Directors adopts a Rights Plan, such Rights Plan will be put to a vote of stockholders within 135 days of the date of adoption of such Rights Plan (the "135th Day Deadline"). If the Corporation fails to hold a stockholder vote on or prior to the 135th Day Deadline, then the Rights Plan shall automatically terminate on the 135th Day Deadline. If a stockholder vote is held on the Rights Plan and it is not approved by the holders of a majority of shares voted, then the Rights Plan shall expire on a date not later than the 135th Day Deadline. "Rights Plan" shall mean any plan or arrangement of the sort commonly referred to as a "rights plan" or "stockholder rights plan" or "shareholder rights plan" or "poison pill" that is designed to increase the cost to a potential acquirer of exceeding the applicable ownership thresholds through the issuance of common stock, new rights or preferred shares (or any other security or device that may be issued to stockholders of the Corporation, other than ratably to all stockholders of the Corporation) that carry severe redemption provisions, favorable purchase provisions or otherwise, and any related rights agreement. The term "beneficial ownership" as used in the Rights Plan shall mean beneficial ownership as such term is defined in Rule 13d-3 promulgated by the United States Securities and Exchange Commission under the Securities Exchange Act of 1934, as amended (as now or hereafter amended).

ARTICLE IX - INDEMNIFICATION OF DIRECTORS AND OFFICERS

Section 1. Right to Indemnification.

Each person who was or is made a party or is threatened to be made a party to or is otherwise involved in any action, suit or proceeding, whether civil, criminal, administrative or

investigative (hereinafter a “proceeding”), by reason of the fact that he or she is or was a director or an officer of the Corporation or is or was serving at the request of the Corporation as a director, officer or trustee of another Corporation or of a partnership, joint venture, trust or other enterprise, including service with respect to an employee benefit plan (hereinafter an “indemnitee”), whether the basis of such proceeding is alleged action in an official capacity as a director, officer or trustee or in any other capacity while serving as a director, officer or trustee, shall be indemnified and held harmless by the Corporation to the fullest extent permitted by Delaware law, as the same exists or may hereafter be amended (but, in the case of any such amendment, only to the extent that such amendment permits the Corporation to provide broader indemnification rights than such law permitted the Corporation to provide prior to such amendment), against all expense, liability and loss (including attorneys’ fees, judgments, fines, ERISA excise taxes or penalties and amounts paid in settlement) reasonably incurred or suffered by such indemnitee in connection therewith; provided, however, that, except as provided in Section 3 of this Article IX with respect to proceedings to enforce rights to indemnification, the Corporation shall indemnify any such indemnitee in connection with a proceeding (or part thereof) initiated by such indemnitee only if such proceeding (or part thereof) was authorized by the Board of Directors of the Corporation.

### Section 2. Right to Advancement of Expenses.

In addition to the right to indemnification conferred in Section 1 of this Article IX, an indemnitee shall also have the right to be paid by the Corporation the expenses (including attorney’s fees) incurred in defending any such proceeding in advance of its final disposition (hereinafter an “advancement of expenses”); provided, however, that, if the DGCL requires, an advancement of expenses incurred by an indemnitee in his or her capacity as a director or officer (and not in any other capacity in which service was or is rendered by such indemnitee, including, without limitation, service to an employee benefit plan) shall be made only upon delivery to the Corporation of an undertaking (hereinafter an “undertaking”), by or on behalf of such indemnitee, to repay all amounts so advanced if it shall ultimately be determined by final judicial decision from which there is no further right to appeal (hereinafter a “final adjudication”) that such indemnitee is not entitled to be indemnified for such expenses under this Section 2 or otherwise.

### Section 3. Right of Indemnitee to Bring Suit.

If a claim under Section 1 or 2 of this Article IX is not paid in full by the Corporation within 60 days after a written claim has been received by the Corporation, except in the case of a claim for an advancement of expenses, in which case the applicable period shall be 20 days, the indemnitee may at any time thereafter bring suit against the Corporation to recover the unpaid amount of the claim. To the fullest extent permitted by law, if successful in whole or in part in any such suit, or in a suit brought by the Corporation to recover an advancement of expenses pursuant to the terms of an undertaking, the indemnitee shall be entitled to be paid also the expense of prosecuting or defending such suit. In (i) any suit brought by the indemnitee to enforce a right to indemnification hereunder (but not in a suit brought by the indemnitee to enforce a right to an advancement of expenses) it shall be a defense that, and (ii) in any suit brought by the Corporation to recover an advancement of expenses pursuant to the terms of an undertaking, the Corporation shall be entitled to recover such expenses upon a final adjudication that, the indemnitee has not met any applicable standard for indemnification set forth in the DGCL. Neither the failure of the Corporation (including its directors who are not parties to such action, a

committee of such directors, independent legal counsel, or its stockholders) to have made a determination prior to the commencement of such suit that indemnification of the indemnitee is proper in the circumstances because the indemnitee has met the applicable standard of conduct set forth in the DGCL, nor an actual determination by the Corporation (including its directors who are not parties to such action, a committee of such directors, independent legal counsel, or its stockholders) that the indemnitee has not met such applicable standard of conduct, shall create a presumption that the indemnitee has not met the applicable standard of conduct or, in the case of such a suit brought by the indemnitee, be a defense to such suit. In any suit brought by the indemnitee to enforce a right to indemnification or to an advancement of expenses hereunder, or brought by the Corporation to recover an advancement of expenses pursuant to the terms of an undertaking, the burden of proving that the indemnitee is not entitled to be indemnified, or to such advancement of expenses, under this Article IX or otherwise shall be on the Corporation.

Section 4. Non-Exclusivity of Rights.

The rights to indemnification and to the advancement of expenses conferred in this Article IX shall not be exclusive of any other right which any person may have or hereafter acquire under any statute, the Corporation's Certificate of Incorporation, Bylaws, agreement, vote of stockholders or directors or otherwise.

Section 5. Insurance.

The Corporation may maintain insurance, at its expense, to protect itself and any director, officer, employee or agent of the Corporation or another Corporation, partnership, joint venture, trust or other enterprise against any expense, liability or loss, whether or not the Corporation would have the power to indemnify such person against such expense, liability or loss under the DGCL.

Section 6. Indemnification of Employees and Agents of the Corporation.

The Corporation may, to the extent authorized from time to time by the Board of Directors, grant rights to indemnification and to the advancement of expenses to any employee or agent of the Corporation to the fullest extent of the provisions of this Article with respect to the indemnification and advancement of expenses of directors and officers of the Corporation.

Section 7. Nature of Rights.

The rights conferred upon indemnitees in this Article IX shall be contract rights and such rights shall continue as to an indemnitee who has ceased to be a director, officer or trustee and shall inure to the benefit of the indemnitee's heirs, executors and administrators. Any amendment, alteration or repeal of this Article IX that adversely affects any right of an indemnitee or its successors shall be prospective only and shall not limit, eliminate, or impair any such right with respect to any proceeding involving any occurrence or alleged occurrence of any action or omission to act that took place prior to such amendment or repeal.

## ARTICLE X - AMENDMENTS

In furtherance and not in limitation of the powers conferred by law, the Board of Directors is expressly authorized to adopt, amend and repeal these Bylaws subject to the power of the holders of capital stock of the Corporation to adopt, amend or repeal the Bylaws; provided, however, that, with respect to the power of holders of capital stock to adopt, amend and repeal Bylaws of the Corporation, notwithstanding any other provision of these Bylaws or any provision of law which might otherwise permit a lesser vote or no vote, but in addition to any affirmative vote of the holders of any particular class or series of the capital stock of the Corporation required by law, these Bylaws or any preferred stock, the affirmative vote of the holders of a majority of the voting power of all of the then-outstanding shares entitled to vote generally in the election of directors, voting together as a single class, shall be required to adopt, amend or repeal any provision of these Bylaws.

## ARTICLE XI – SECTION 203 OF THE DGCL

The Corporation shall not be governed by or subject to the provisions of Section 203 of the DGCL as now in effect or hereafter amended, or any successor statute thereto.