

CULTURALLY INCLUSIVE MINDSET CLASSROOMS
DR. STEPHANIE FRYBERG

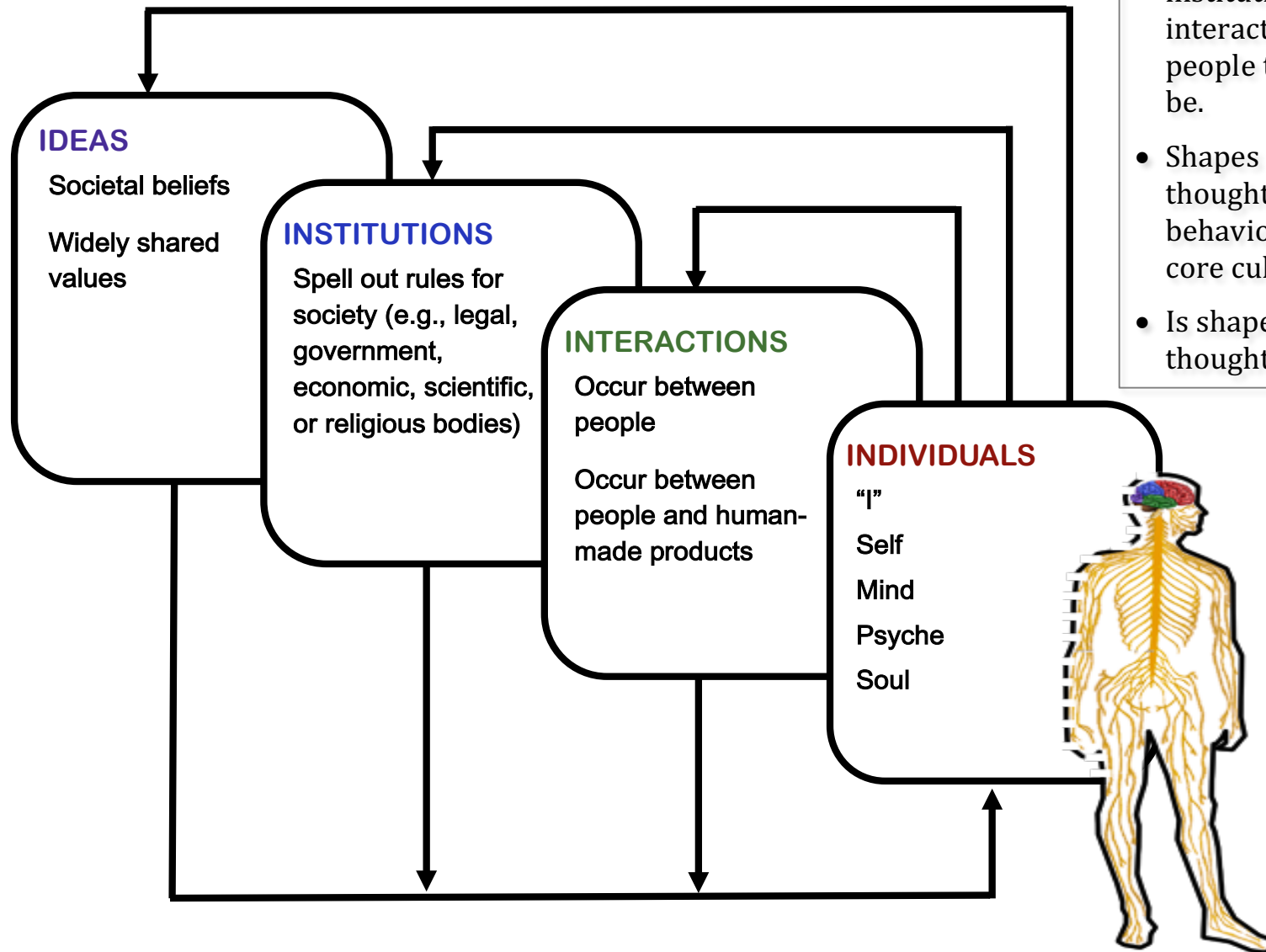

The Culture Cycle: Components



Culture:

- Is made up of the ideas, institutions, and interactions that tell people the "right" way to be.
- Shapes individuals' thoughts, attitudes, and behaviors to align with core cultural ideas
- Is shaped by individuals' thoughts, attitudes, and

The Culture Cycle: Examples

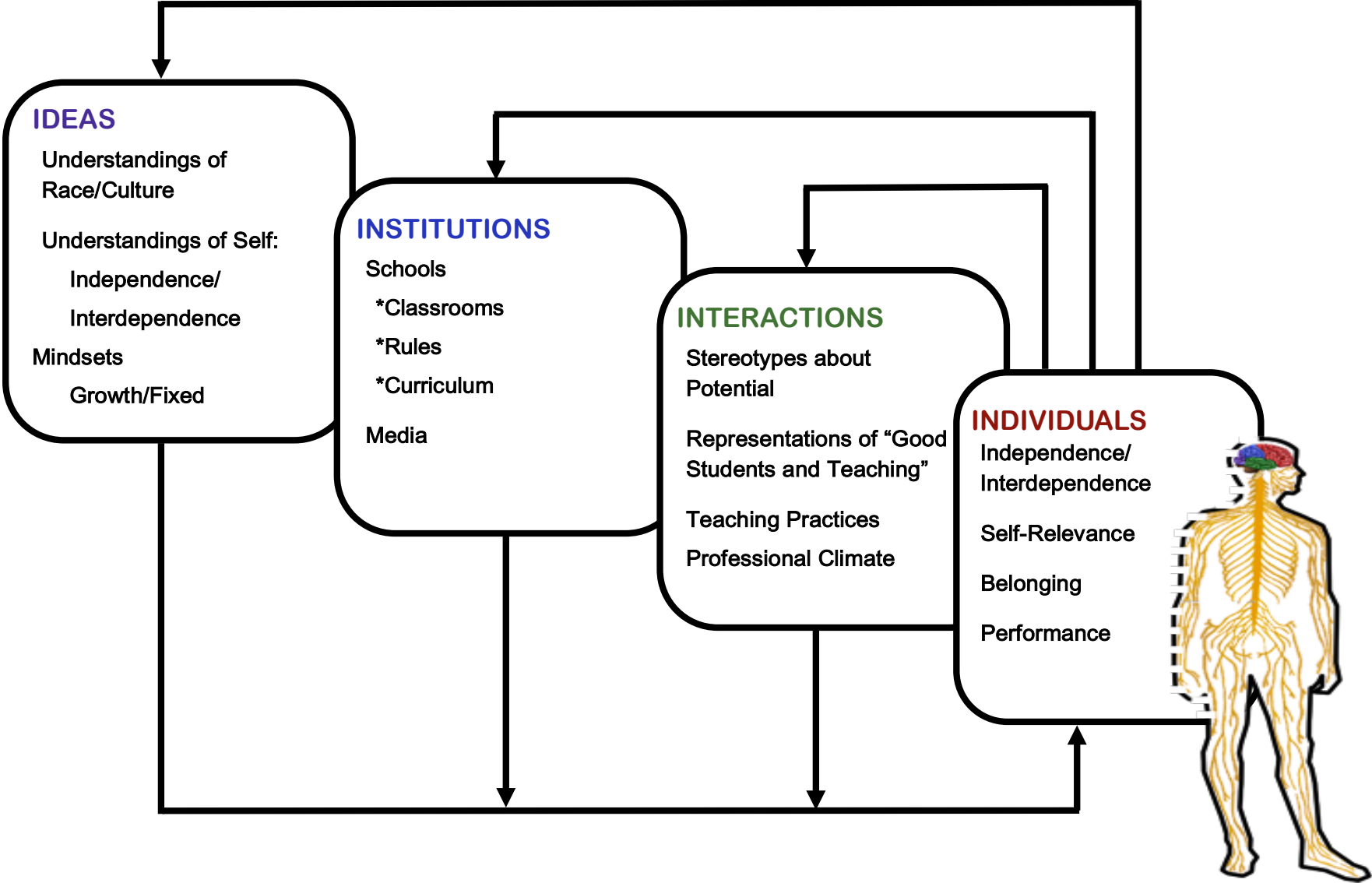

Activity: Culture of Your School/Classroom

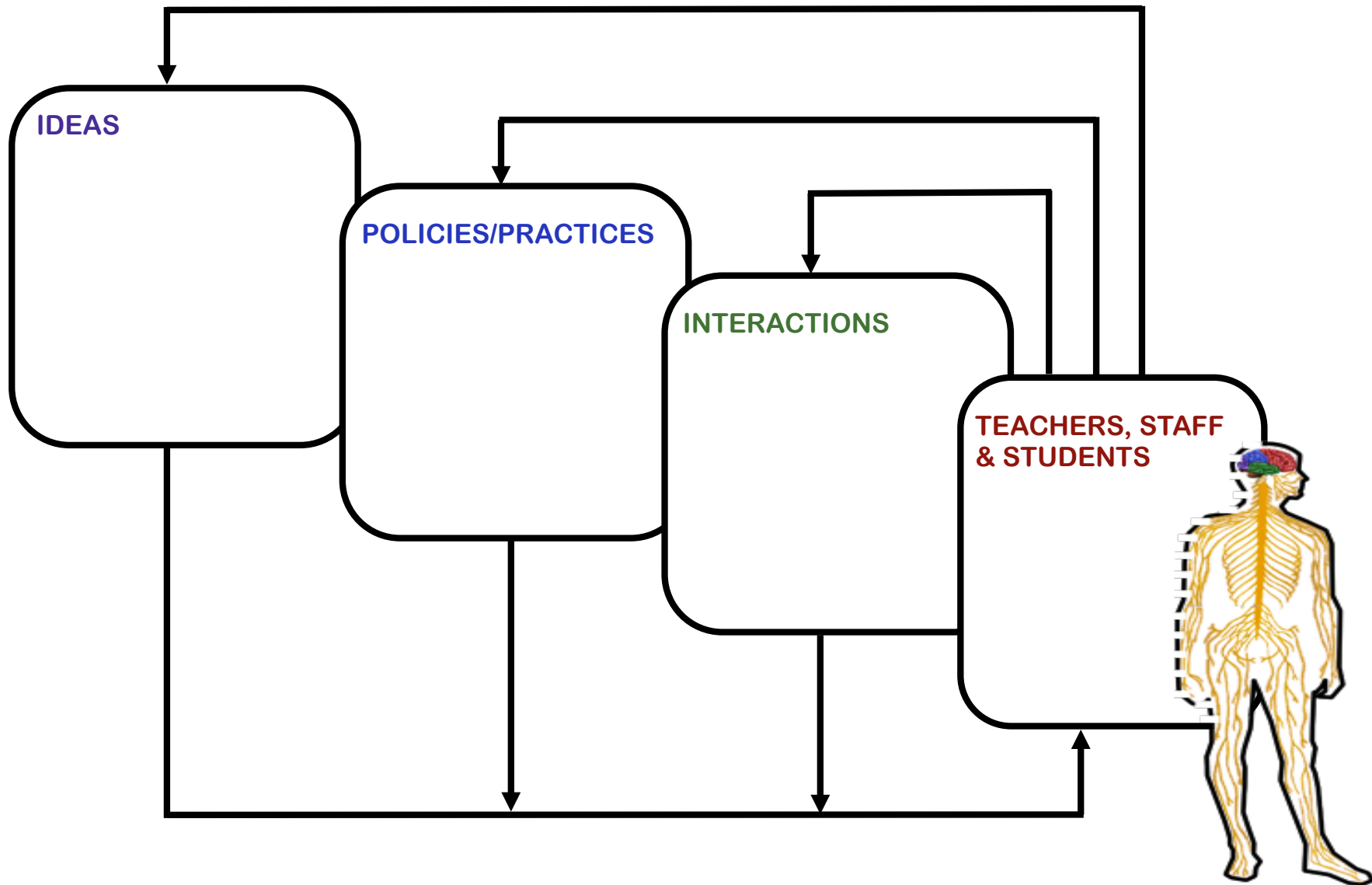

School Culture: Practices and Polices

	Teachers	Staff	Students
What behaviors do you want to encourage in teachers, staff and students?			
What behaviors do you want to discourage in teachers, staff and students?			
What rules/practices will support these behaviors in teachers, staff and students?			

Activity: Mapping Classroom Cultures

